

# PROTECTA® FR ACRYLIC

## INSTALLATION INSTRUCTIONS



### CONTENTS

|   |             |
|---|-------------|
| Solutions in rigid floors.....              | pages 2-15  |
| Solutions in flexible and rigid floors..... | pages 15-22 |
| Solutions in timber floors.....             | pages 22-24 |
| Solutions in rigid walls.....               | pages 24-31 |
| Solutions in flexible and rigid walls.....  | pages 31-46 |
| Solutions in panel walls.....               | pages 46-54 |
| Solutions in timber walls.....              | pages 54-57 |
| INDEX for detailed drawings.....            | pages 58-60 |

Please refer to Protecta® FR Damper for guidance on fire sealing ventilation ducts. Please also refer to the Technical Data Sheet.

### GENERAL GUIDE

**Minimum separations and limitations:** Minimum separation between services and the edge of the seal within each aperture should be 10mm to allow for correct fitting of backing and seal depth, however, less width will sustain fire resistance if correct fitting of the fire seal is achieved. Minimum separation between apertures is not required, except where the required fire classification is equal to, or above EI 180, which requires a minimum separation of 30mm.

Protecta® FR Acrylic seals which involve services penetrating both sides of a flexible wall or floor, may also be used in the situation where the services penetrate one side of the wall or floor only, and the remaining side of the wall or floor is not penetrated at the same point (i.e. the services continue on the inside of the construction).

**Supporting constructions:** Flexible walls must have a minimum thickness of 75mm and comprise steel or timber studs lined on both faces with minimum 1 layer of 12.5mm thick boards. Flexible wall solutions may also be used in rigid walls with a minimum density of 350 kg/m<sup>3</sup>. Panel walls must have a minimum thickness of 100mm and comprise steel sheets, minimum 0.5mm thick, on both sides of a mineral fibre core, with a minimum density of 115 kg/m<sup>3</sup>. Timber walls must have a minimum thickness of 100mm and comprise solid wood or cross-laminated timber. Rigid walls must have a minimum thickness of 75mm and comprise concrete, aerated concrete or masonry, with a minimum density of 650 kg/m<sup>3</sup>. Rigid floors must have a minimum thickness of 150mm (except composite floors) and comprise aerated concrete or concrete with a minimum density of 650 kg/m<sup>3</sup>. Flexible floors must have a minimum thickness of 228mm and comprise timber joists with minimum 1 layer of 18.0mm thick boards at top face, and 12.5mm at soffit face. Flexible floor solutions may also be used in rigid floors with a minimum density of 350 kg/m<sup>3</sup>. Timber floors must have a minimum thickness of 150mm and comprise solid wood or cross-laminated timber. Where single sided top face seals are described in the solutions, these can also be used in composite floors (e.g., concrete filled, steel trapezoidal decking).

The supporting construction must be classified in accordance with EN 13501-2 for the required fire resistance period. Services shall be supported at maximum 350mm away from both faces of the wall constructions and 550mm from the upper face of floor constructions. Where cable trays are discontinued on both sides of the penetration seal, the maximum distance to the trays should be 150 mm. There is no minimum distance required for the fixings of the cable trays, but it is suggested such fixings and the cable trays are constructed so they provide support for the duration of the required fire classification.

**Services:** Metallic pipes through the system Protecta® FR Acrylic may be used in all angles between 90° and 45° in all directions. Where steel pipes are mentioned, this includes iron pipes. Where PP pipes are mentioned, this includes PP-MV, PP-H, PP-R and similar. Where PE pipes are mentioned, this includes PE-LD, PE-MD, PE-HD, PE-X and similar.



### INSTALLATION

1. Where Protecta® FR Acrylic is to be installed against surfaces that cannot tolerate direct contact; appropriate surface preparation should be made (contact Polyseam for guidance in these cases). For paints sensitive to sealing compounds, priming with a PVA primer is recommended.
2. As Protecta® FR Acrylic is water based, in cases where corrosion protection is a problem; some metals may require a barrier between the sealant and the metal surface prior to this installation.
3. When installing Protecta® FR Acrylic in hollow floor slabs, top side seals should be completed double sided without reduction of the seal depth on either side. There must be sufficient thickness of concrete below and above the void for the depth of the fire seal. Where this is not the case, tubular voids should be plugged with stone wool backing material before sealing the aperture.
4. An aperture with or without penetrating services, can include a steel or plastic sleeve casted or friction fitted within rigid constructions. Plastic sleeves should have a maximum wall thickness of 14.6 mm.
5. Before installing Protecta® FR Acrylic, ensure that the surface of all service penetrations and surrounding construction is free from all loose contaminants, dust and grease.
6. In gypsum boards and other loose particle boards, the exposed edges of the board should be wetted with water, or Protecta® FR Acrylic diluted with water to prime the surfaces, helping adhesion and preventing excessive joint shrinkage.
7. Find the required sealant depth and backing material in the detailed drawings on pages 2 to 57. If installation does not have to meet any specific fire specification, it is recommended that a width to depth ratio of 2:1 is utilized, with a minimum depth of 12mm of sealant.
8. Use the required backing material and cut this slightly oversize and insert into the gap ensuring a tight friction fit. If no backing material is required, mineral wool or foam backer rod is ideal. Ensure same sealant depth is used within the entire seal.
9. Fill the gap or joint with Protecta® FR Acrylic to the required depth. Apply the sealant generously to prevent air bubbles. Finish the bead with a moist spatula, pallet knife or brush.
10. Protecta® FR Acrylic can be over-painted with most emulsion or alkyd (gloss) paints.

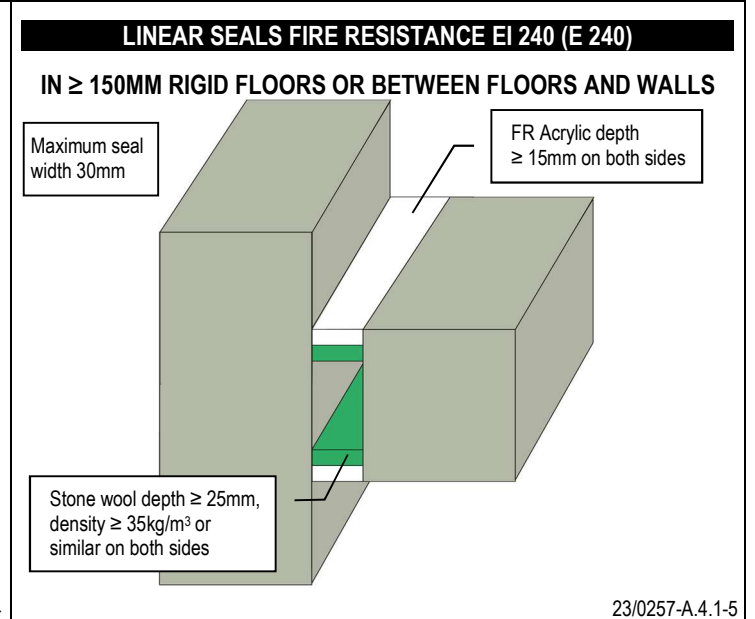
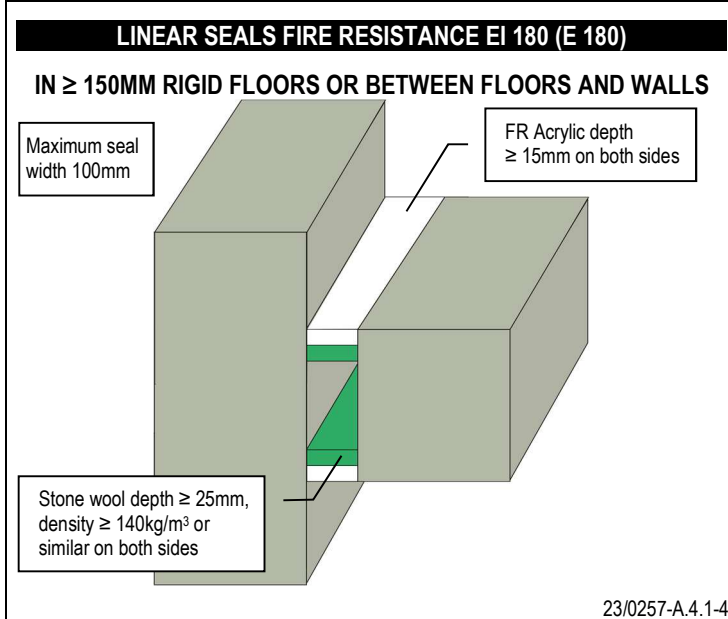
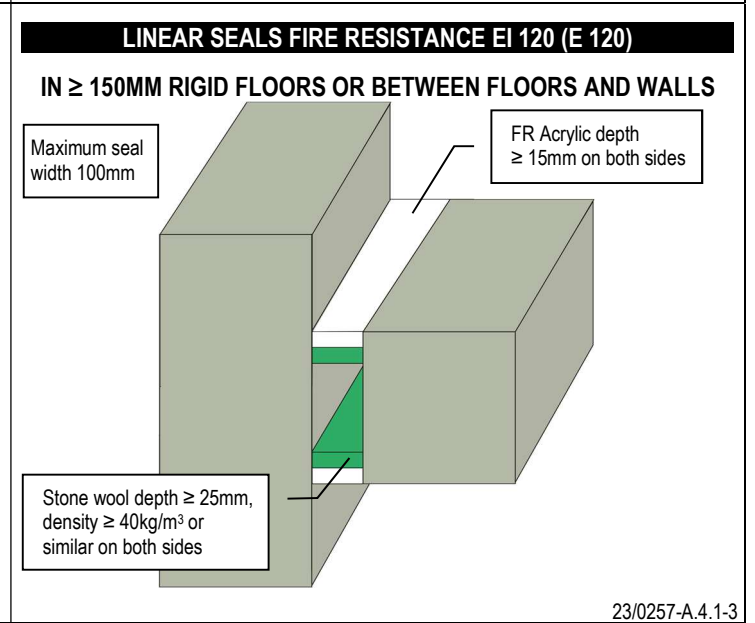
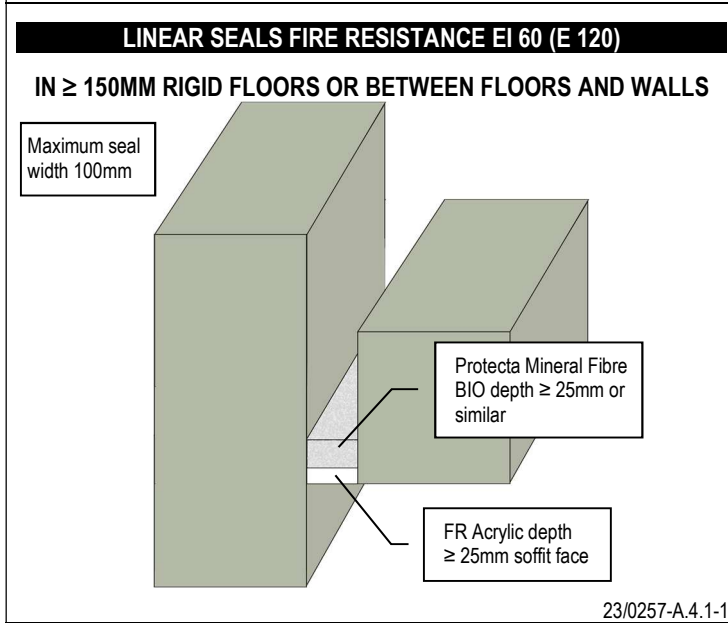
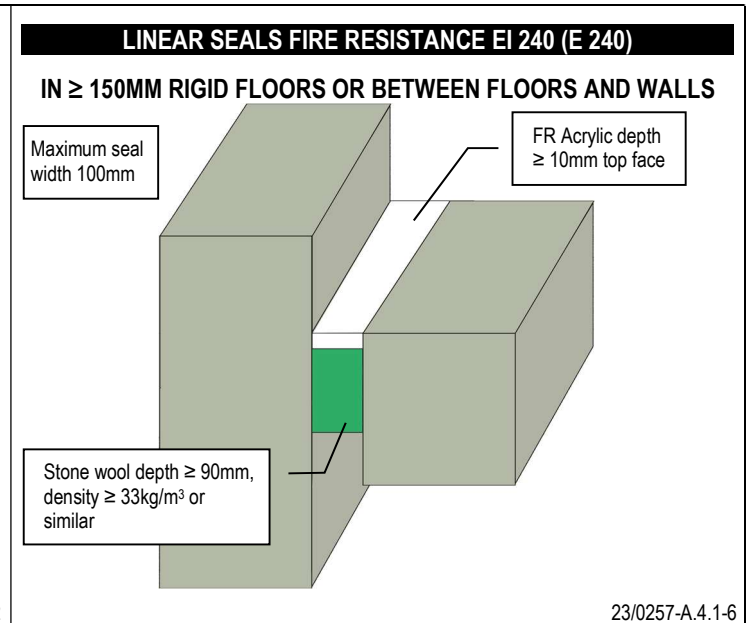
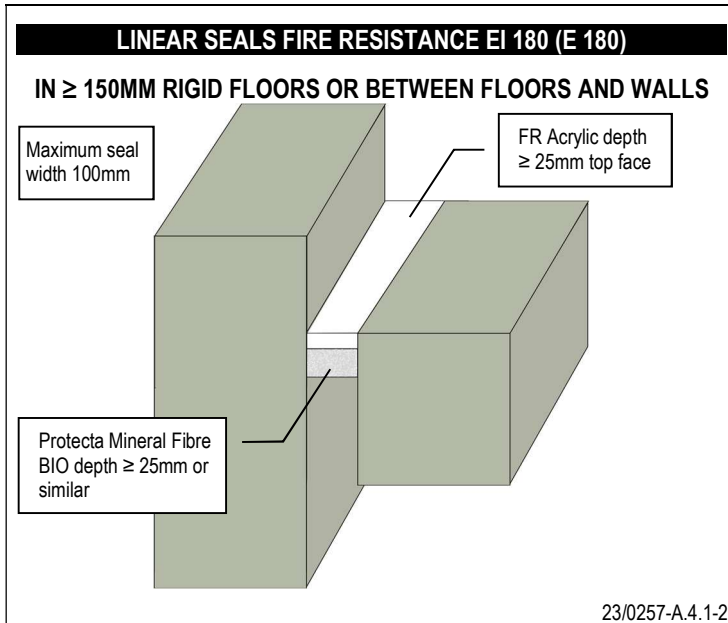

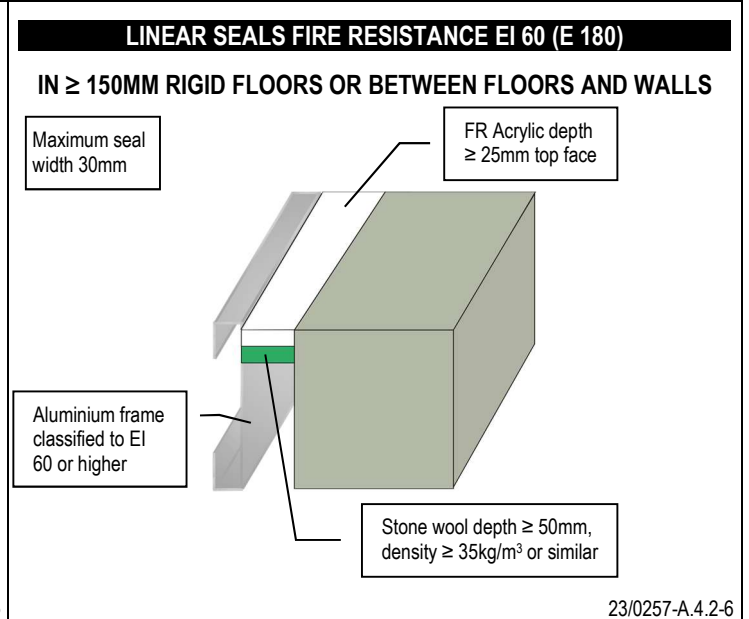
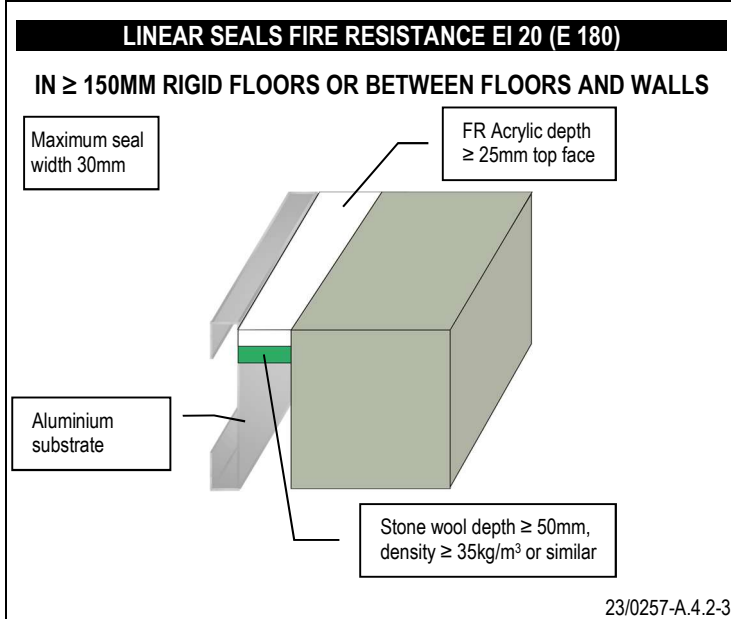
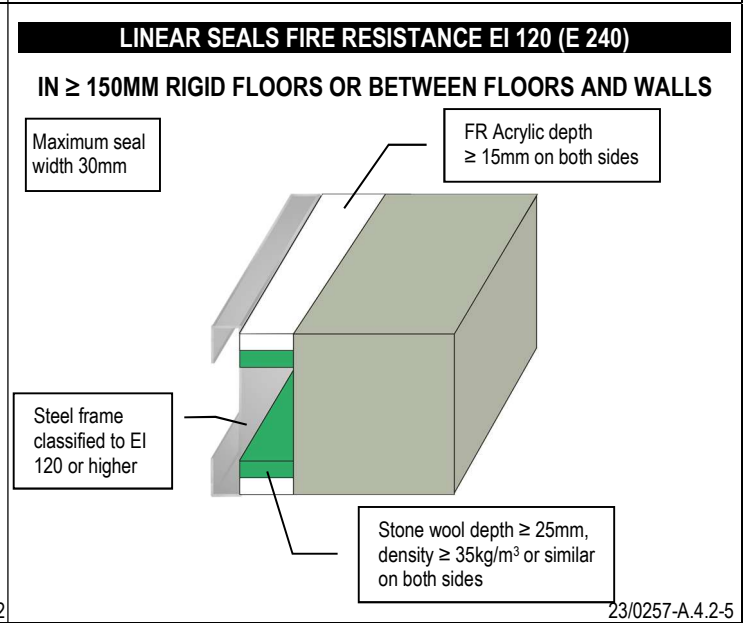
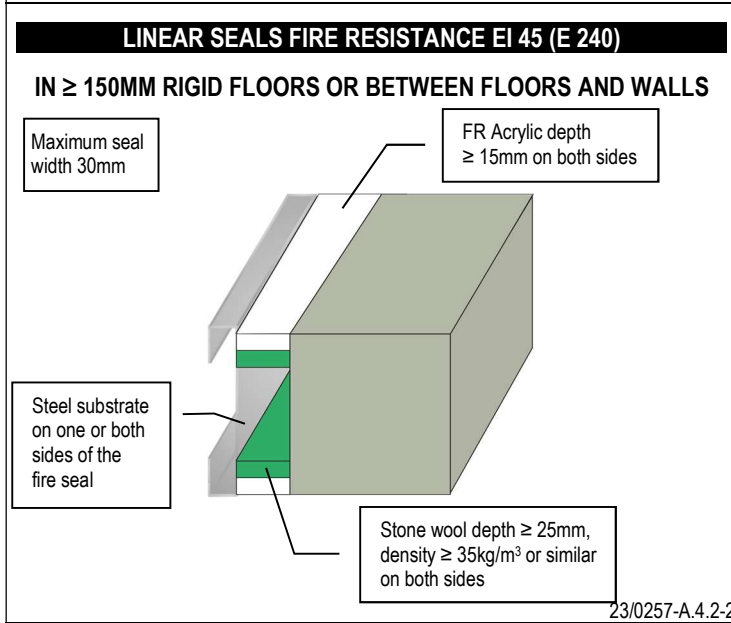
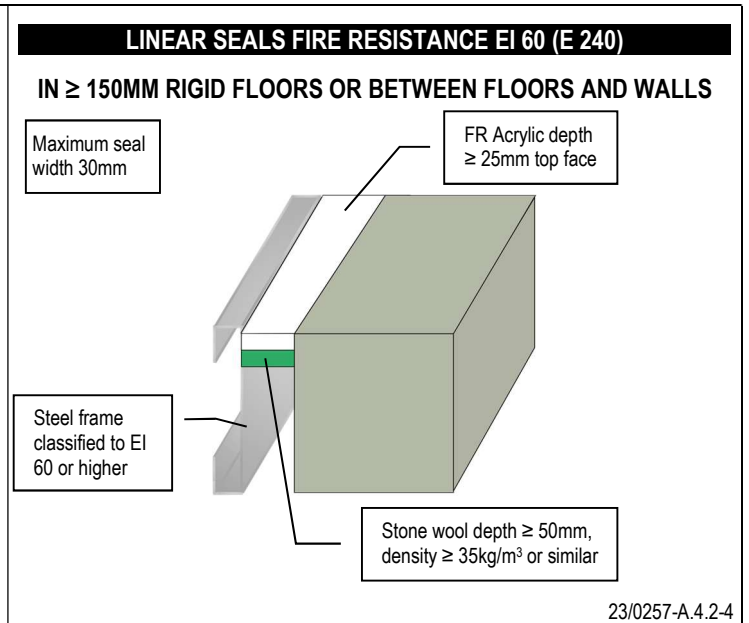
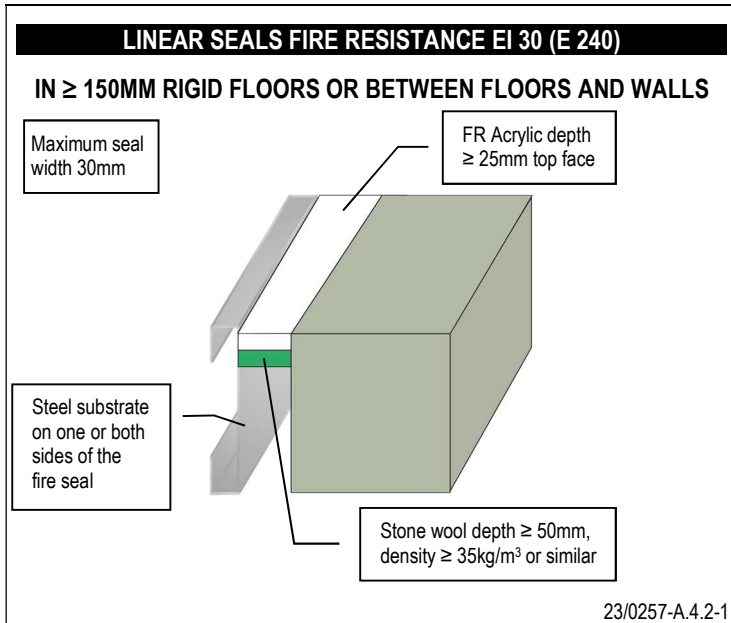

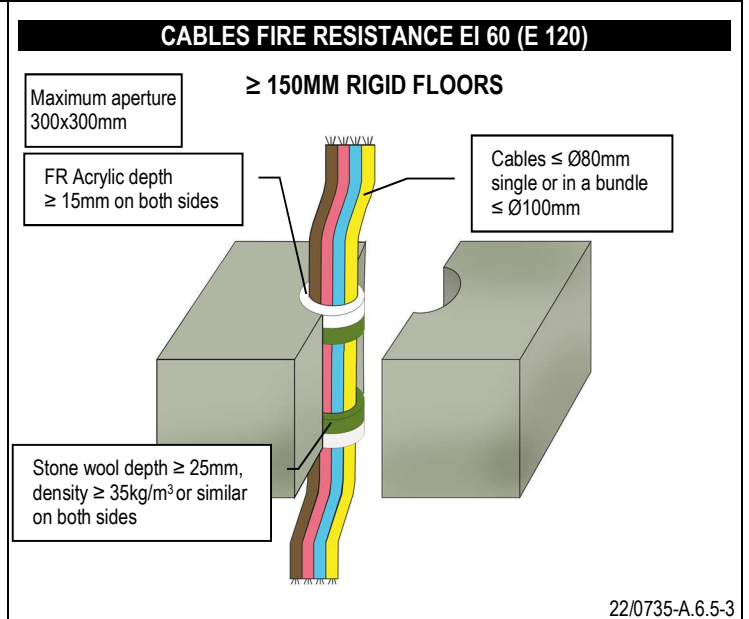
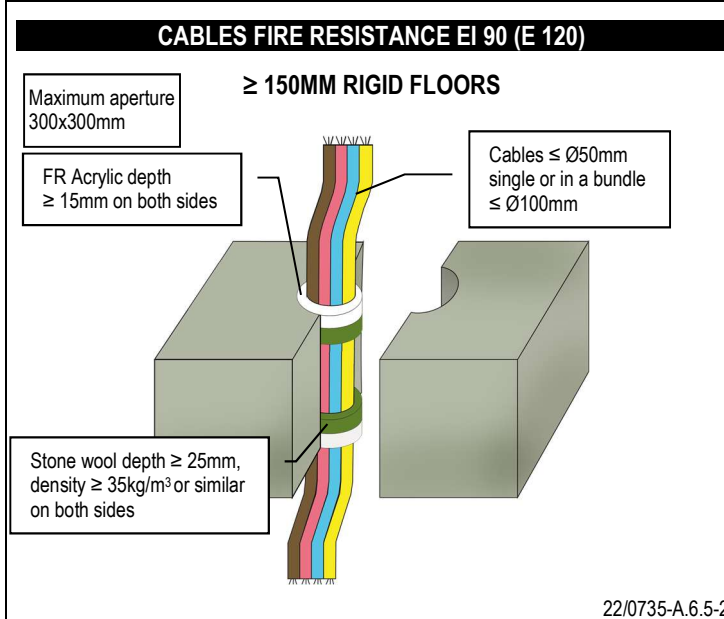
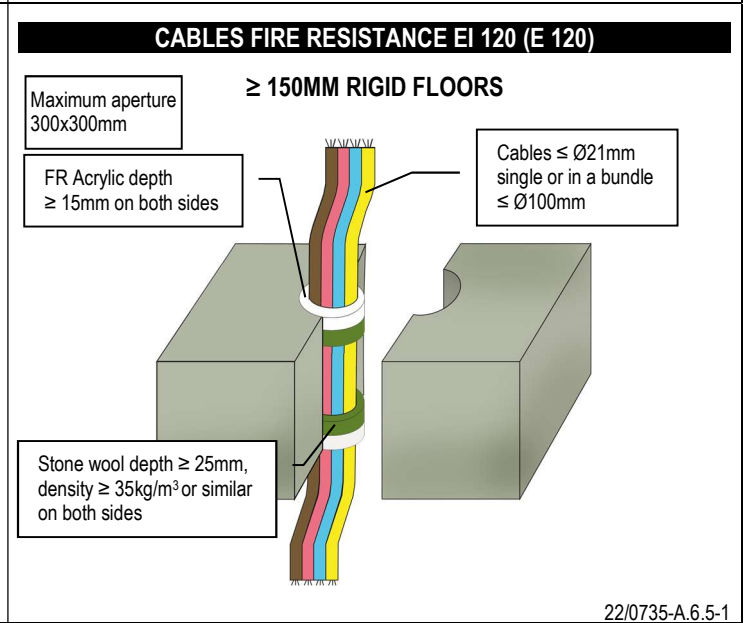
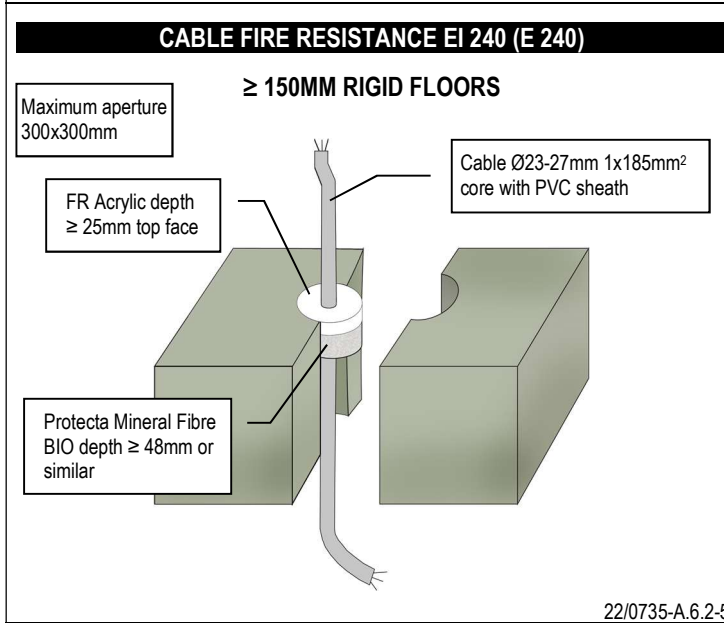
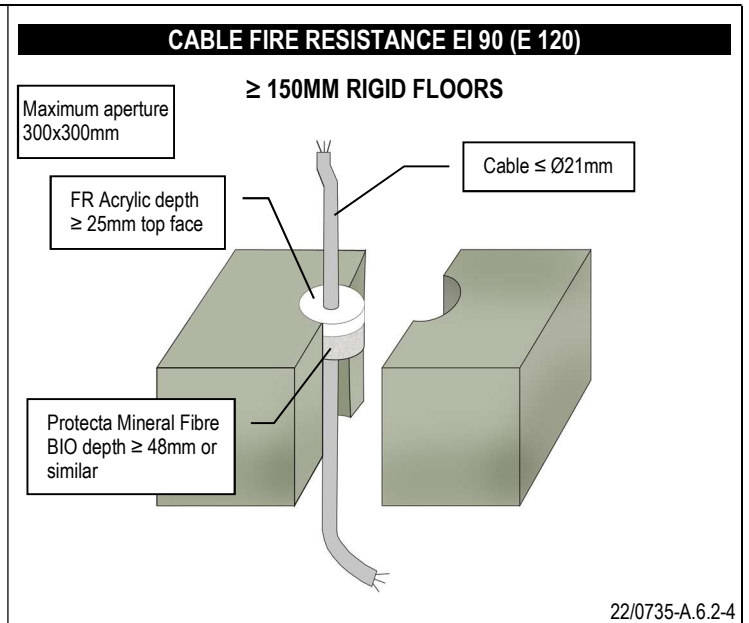
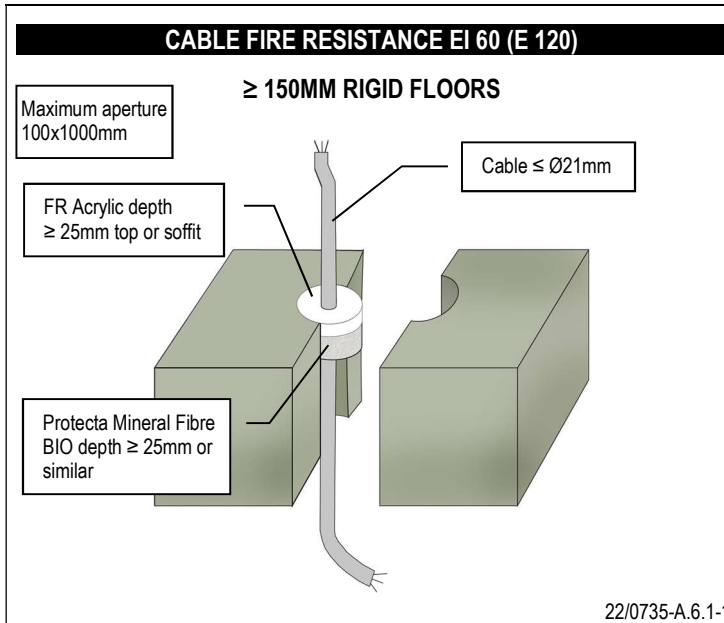

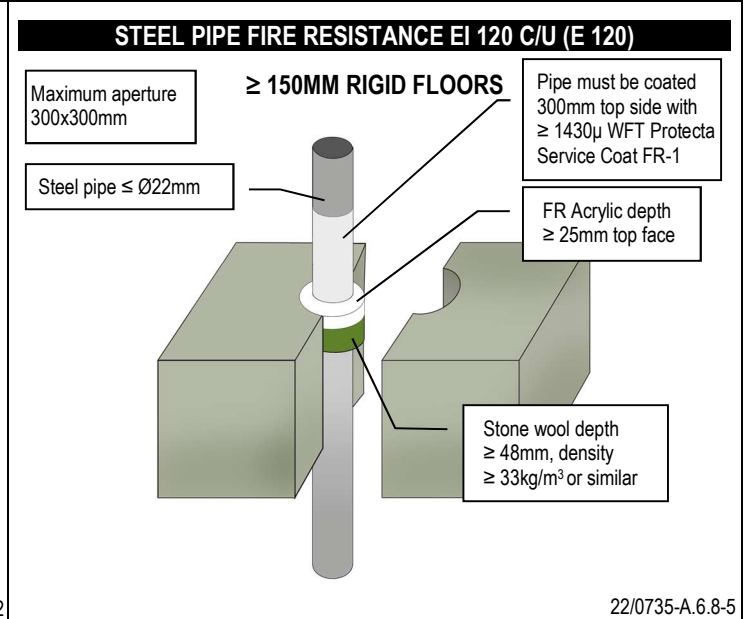
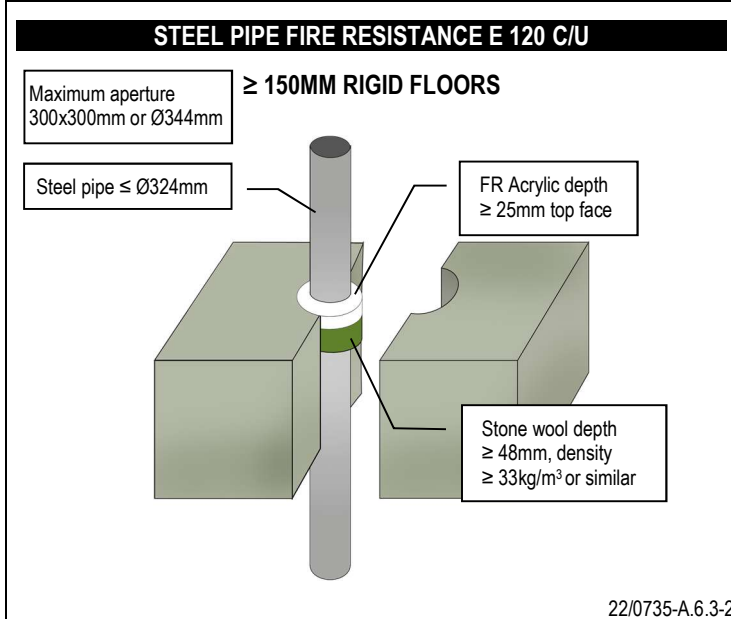
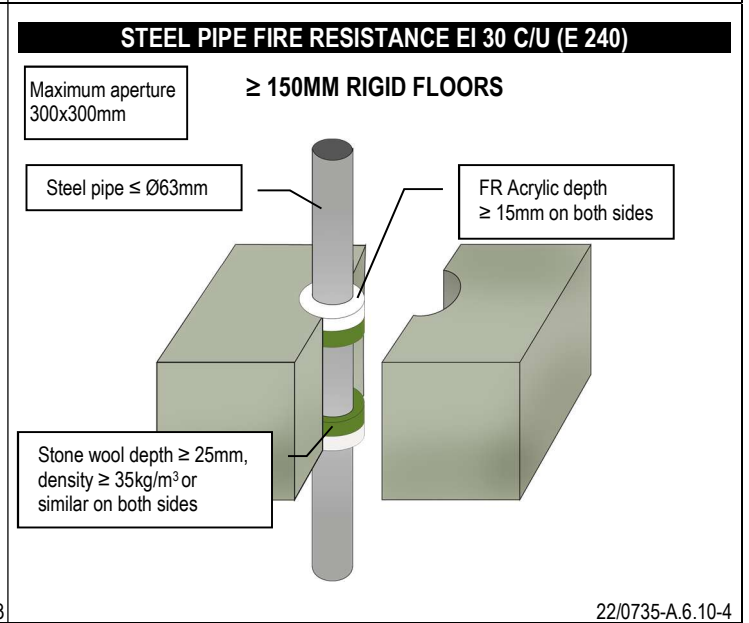
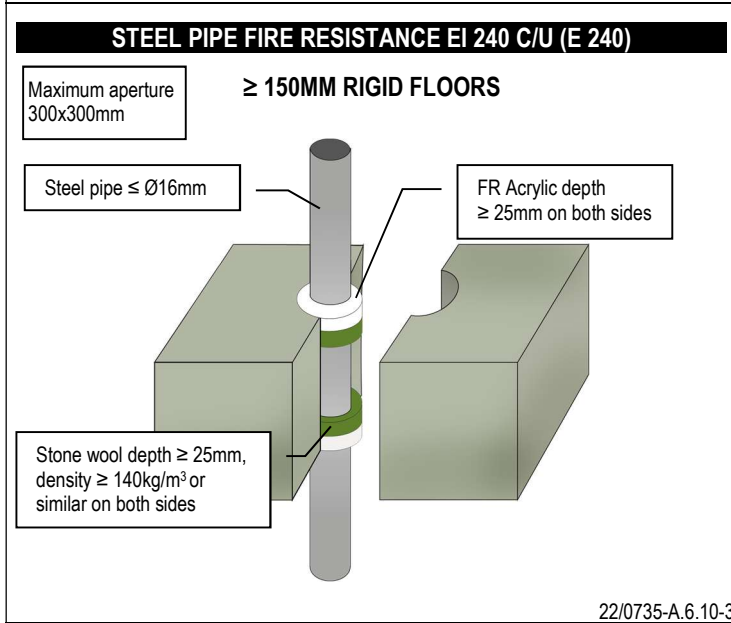
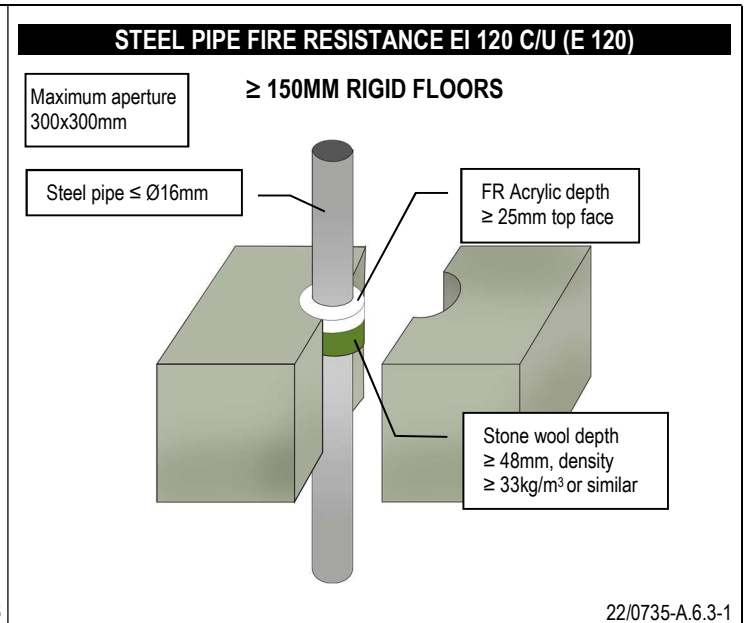
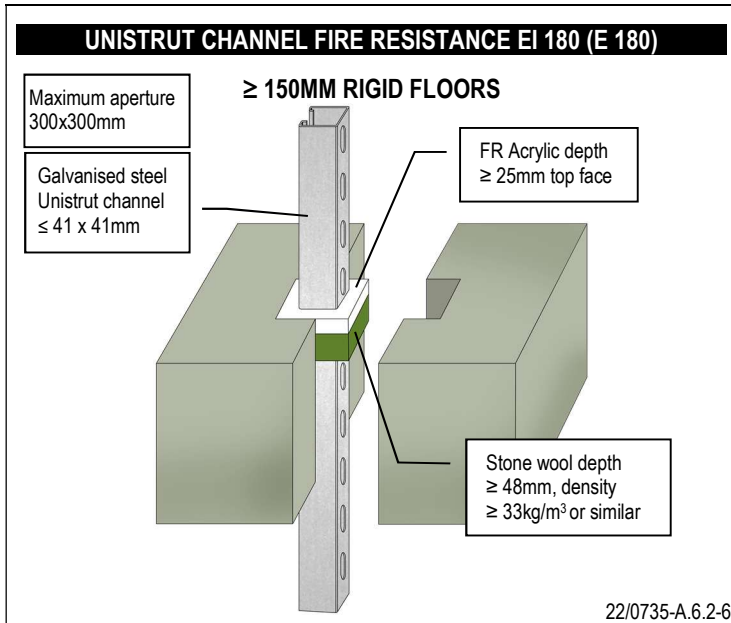

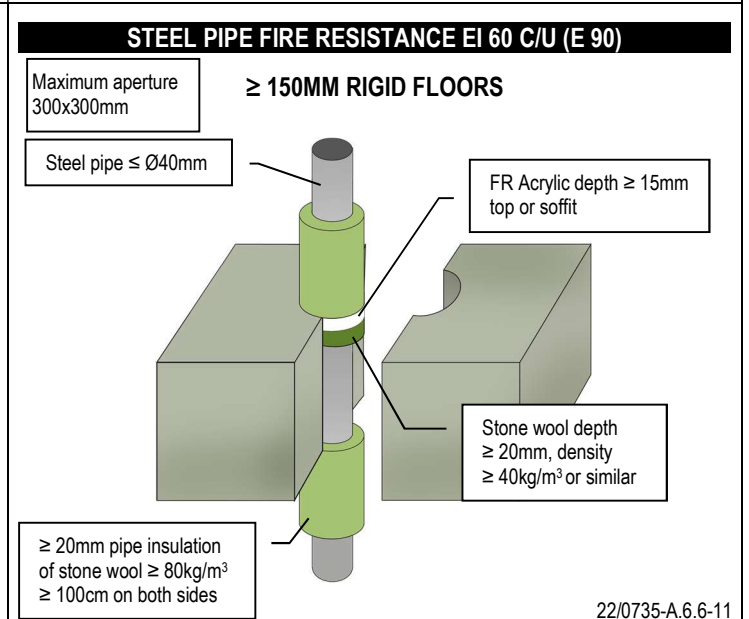
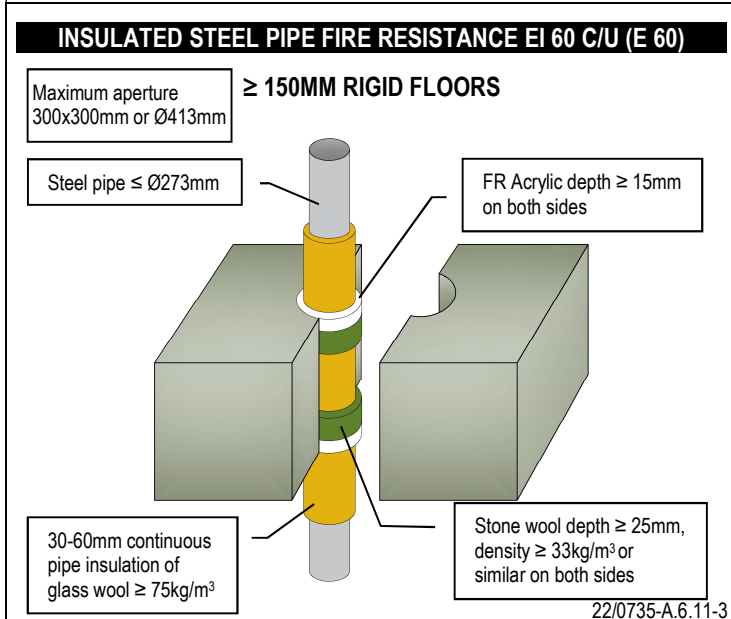
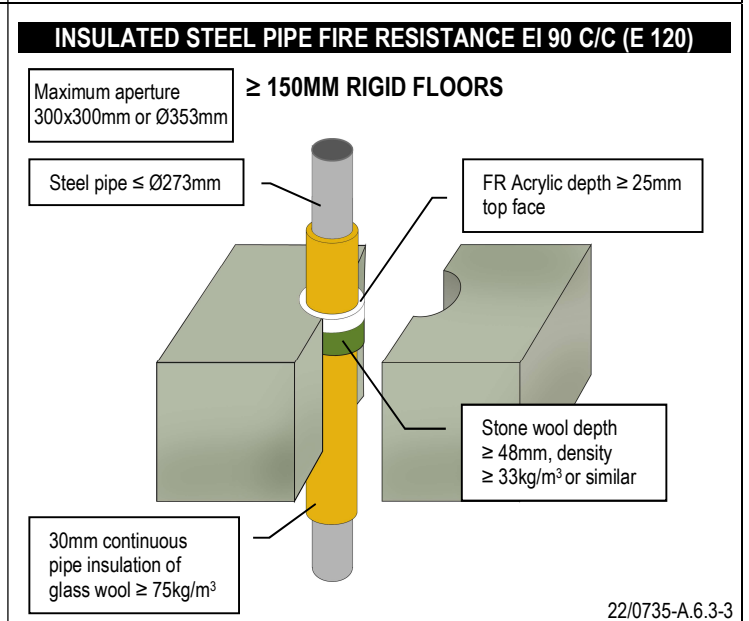
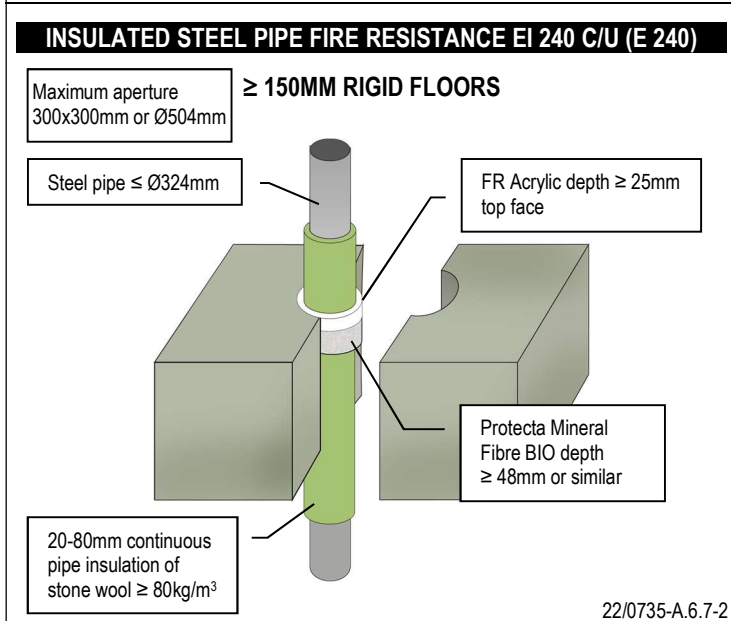
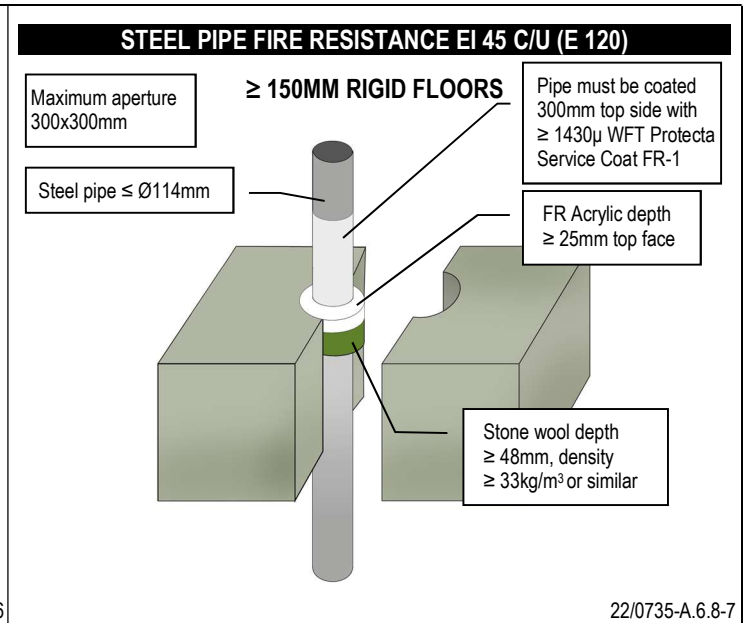
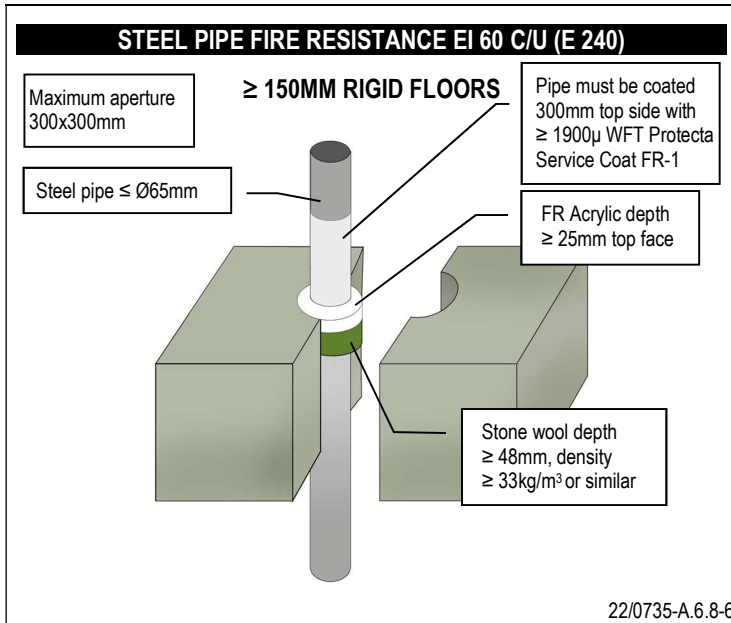

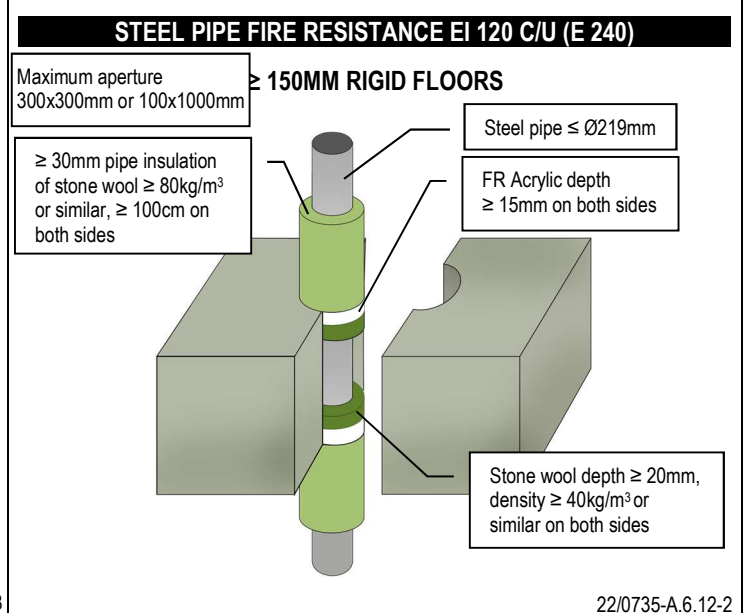
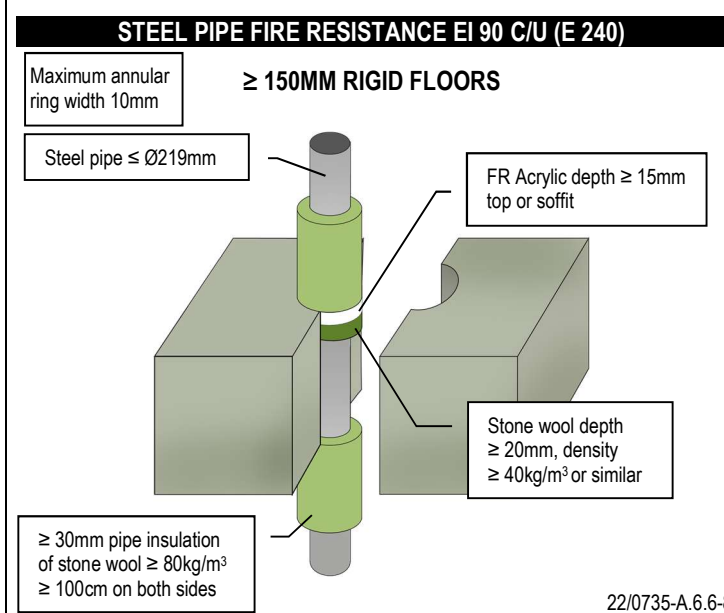
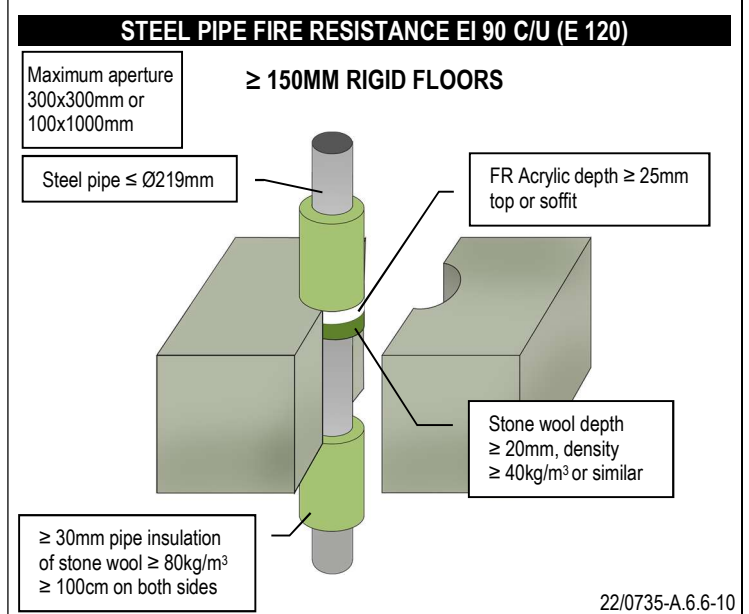
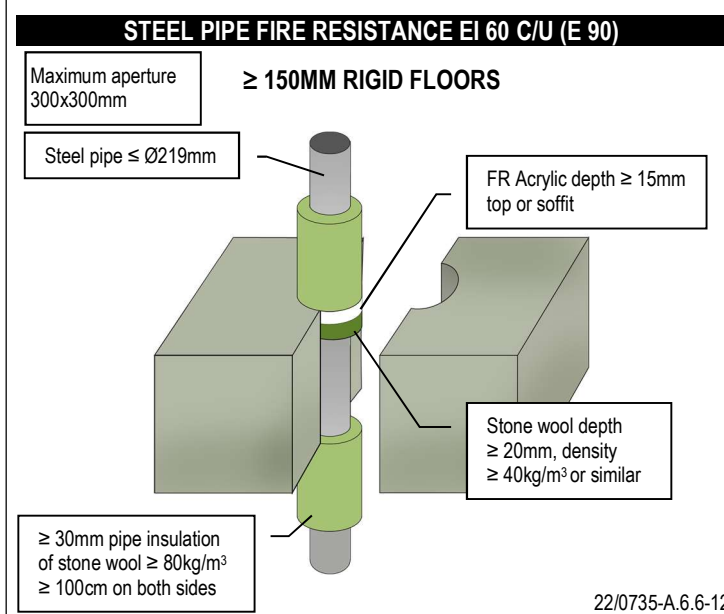
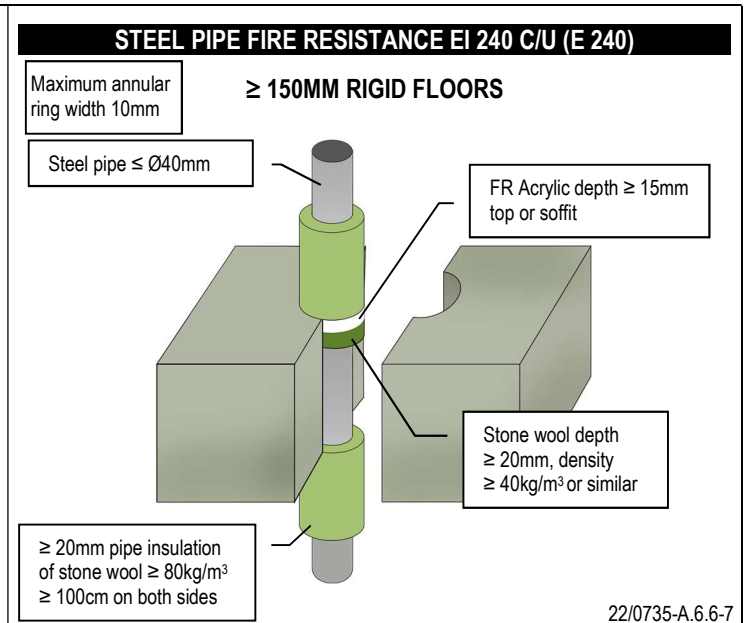
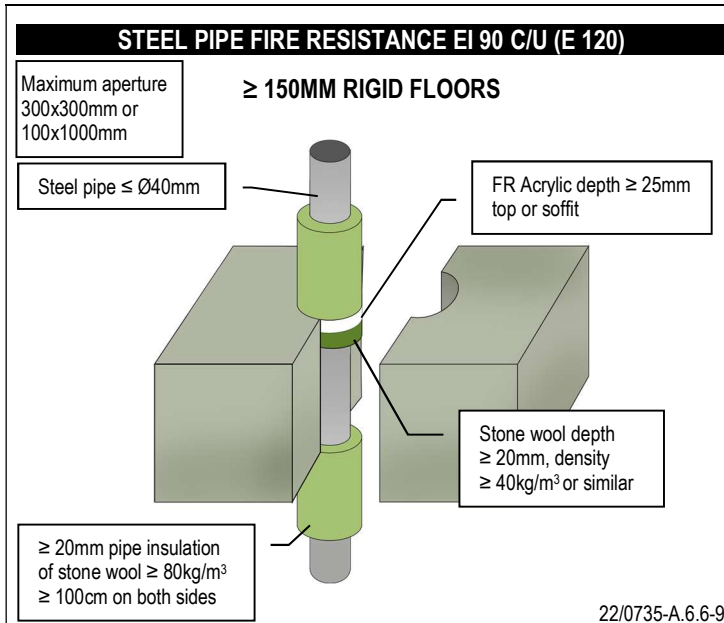

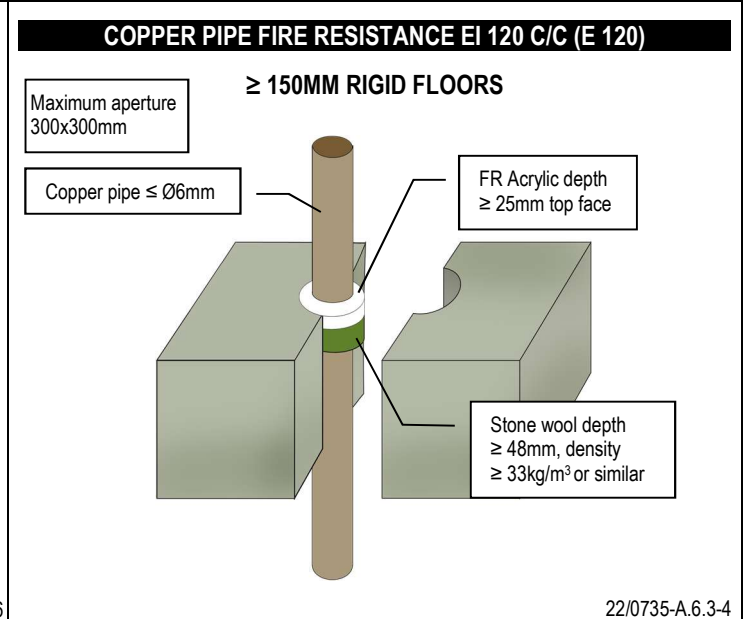
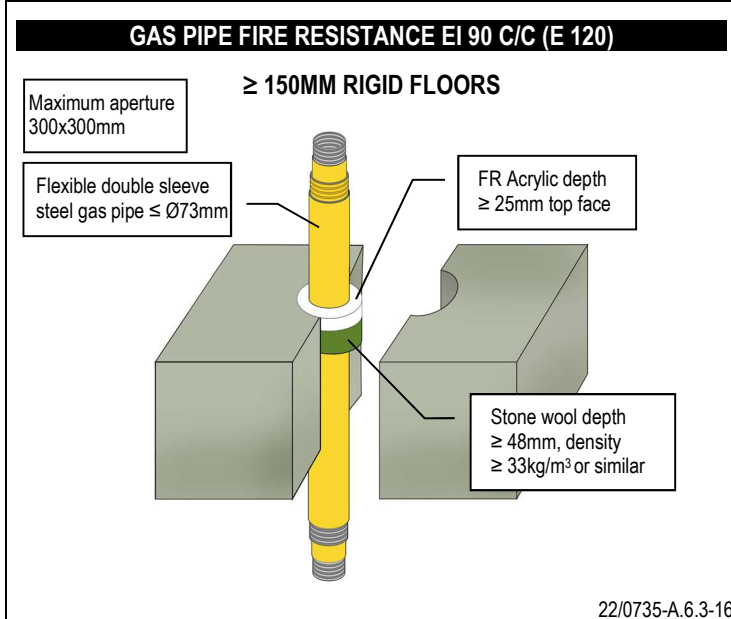
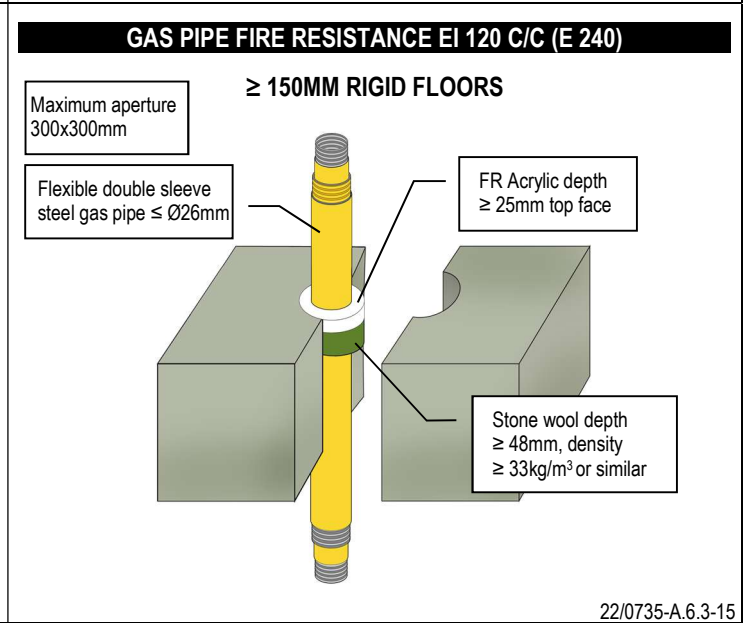
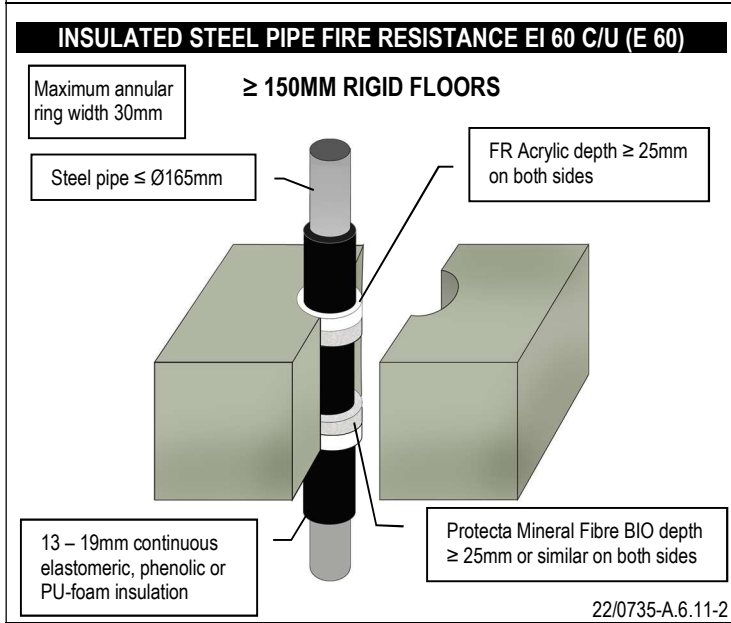
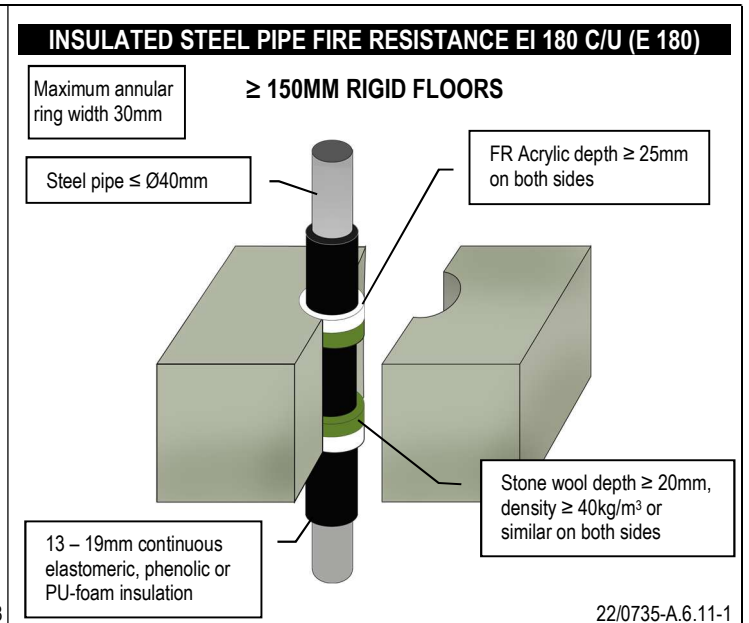
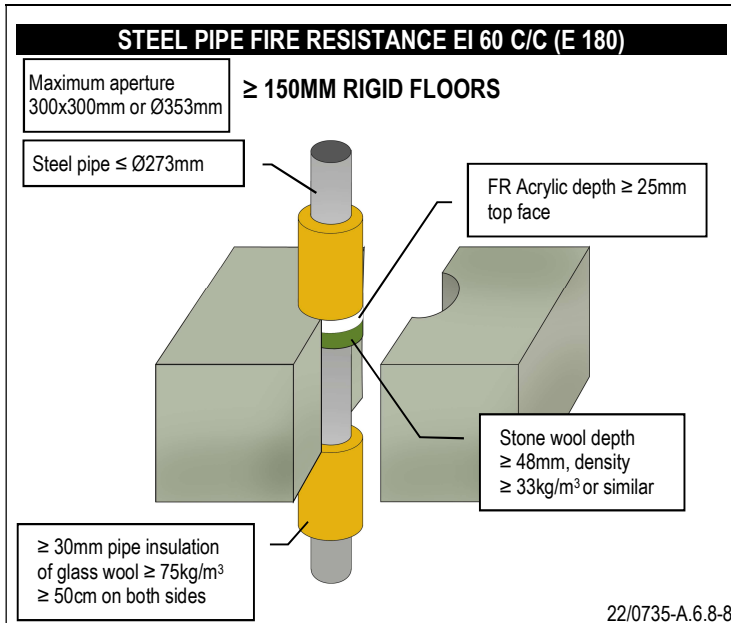

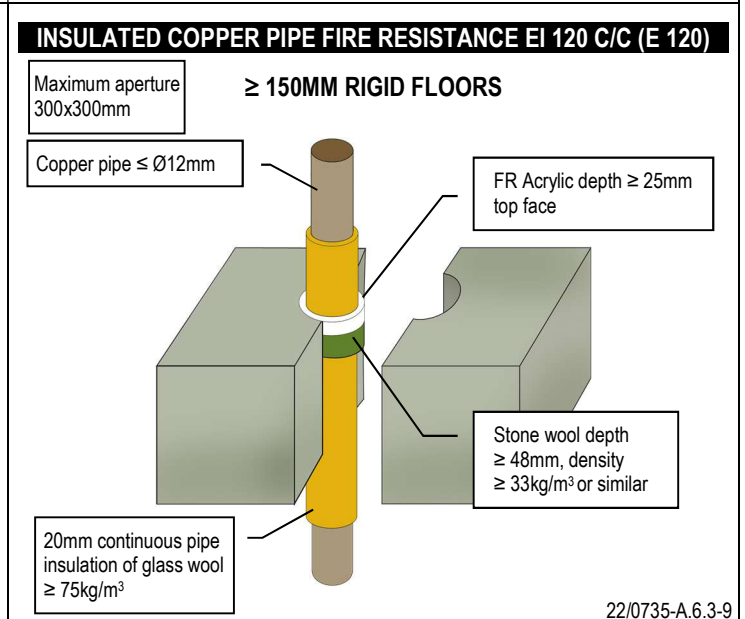
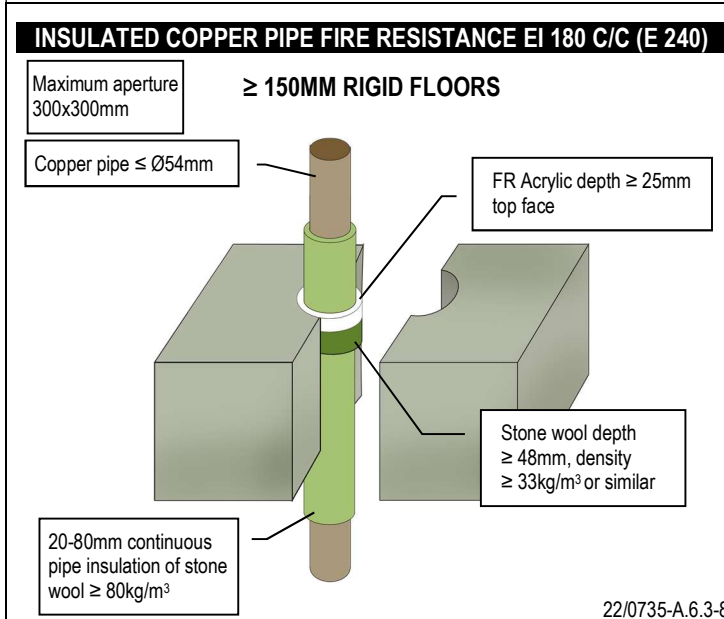
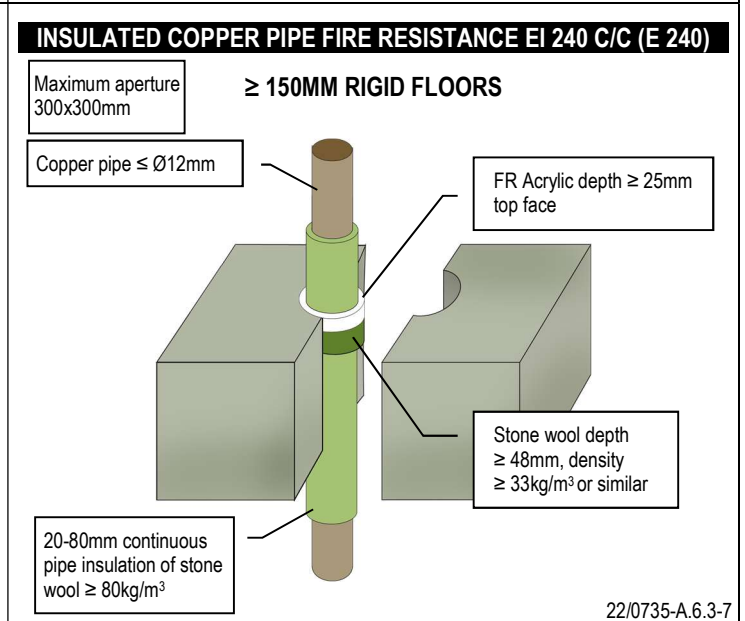
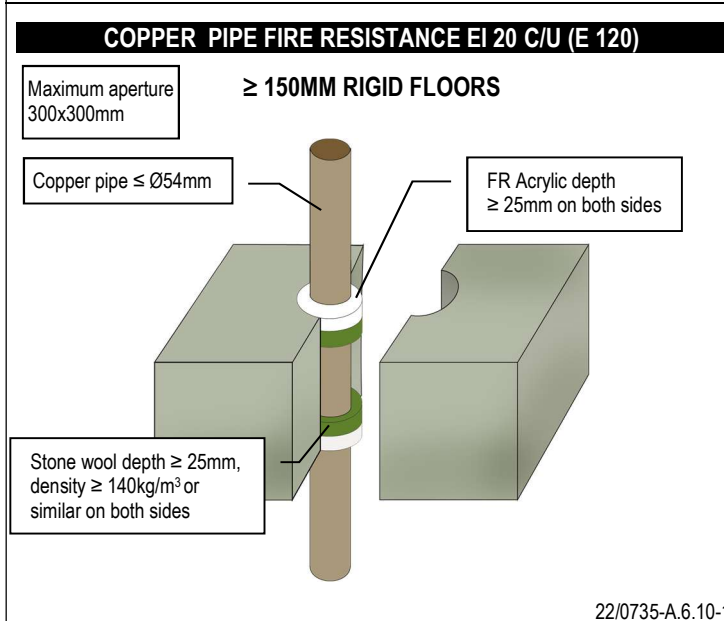
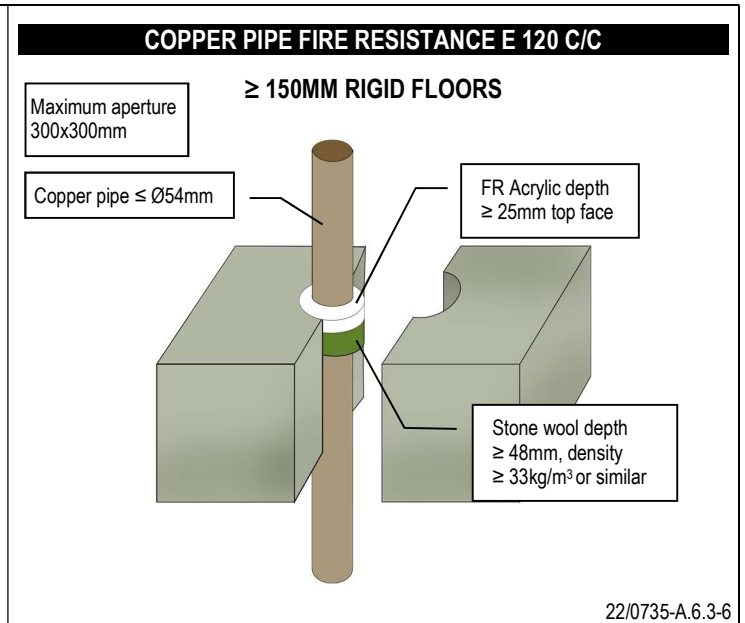
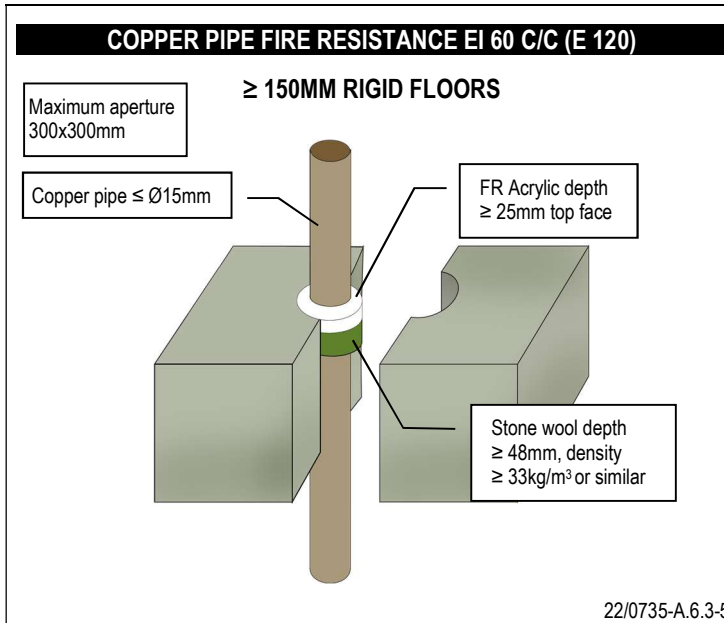

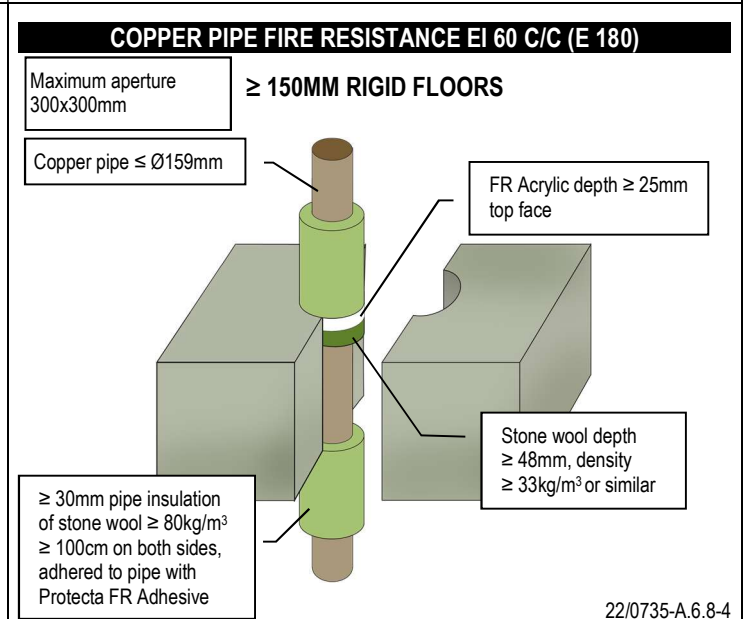
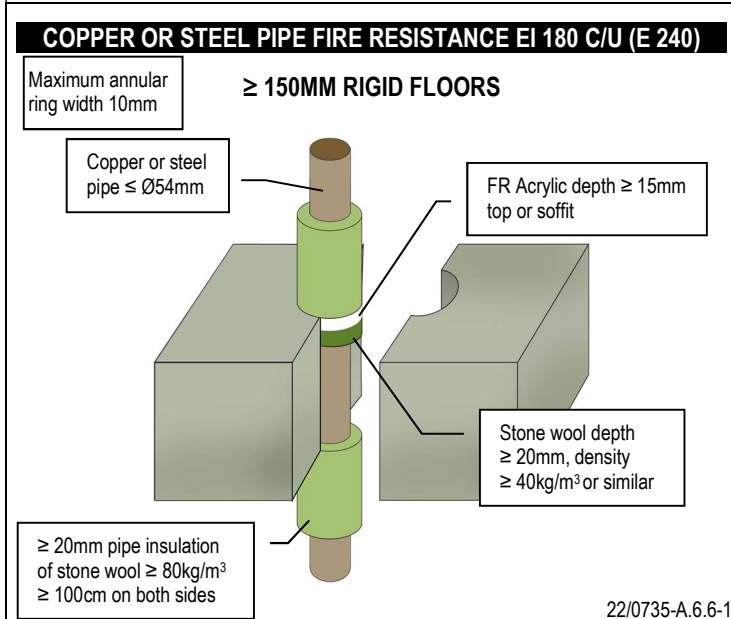
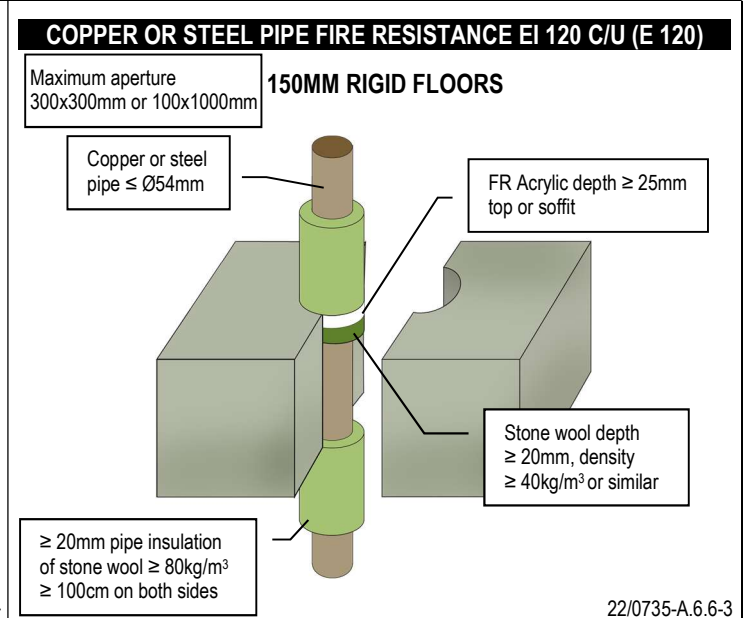
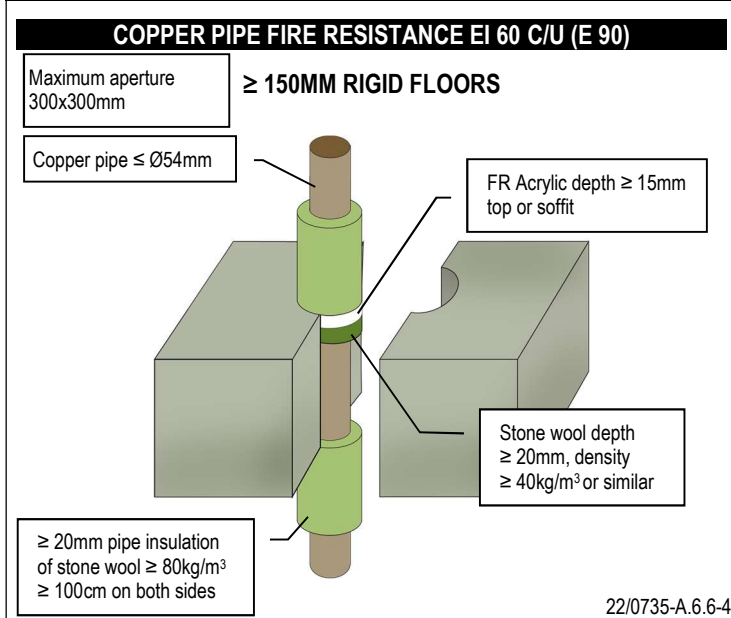
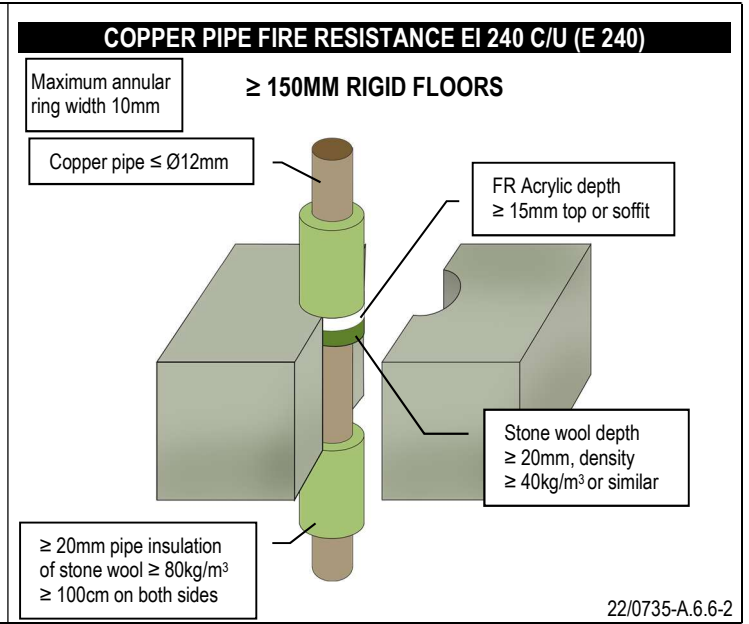
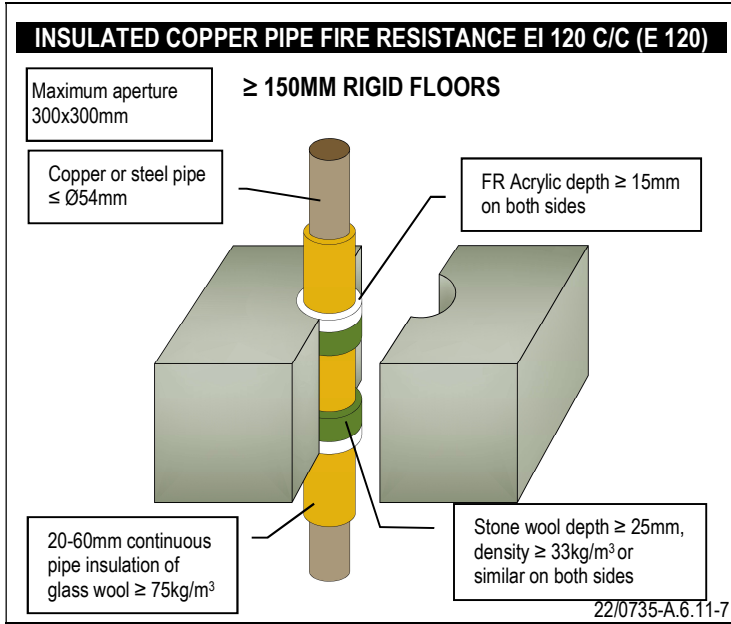

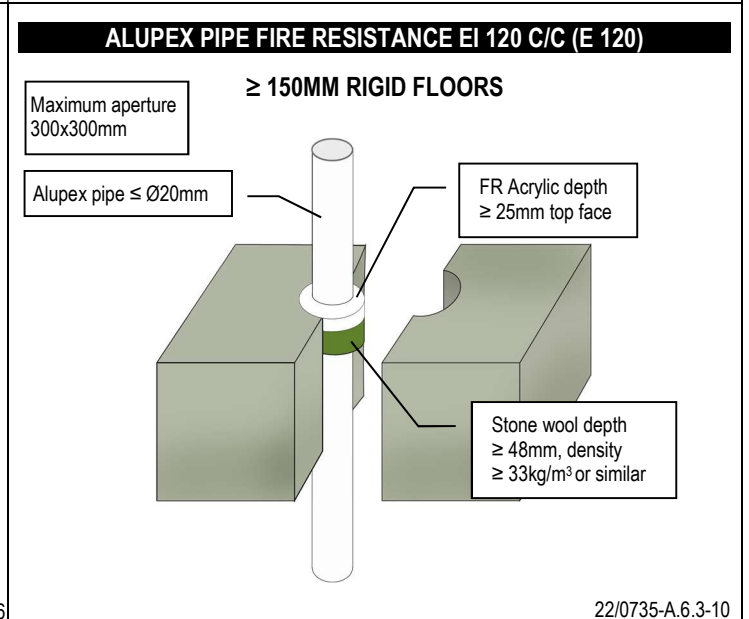
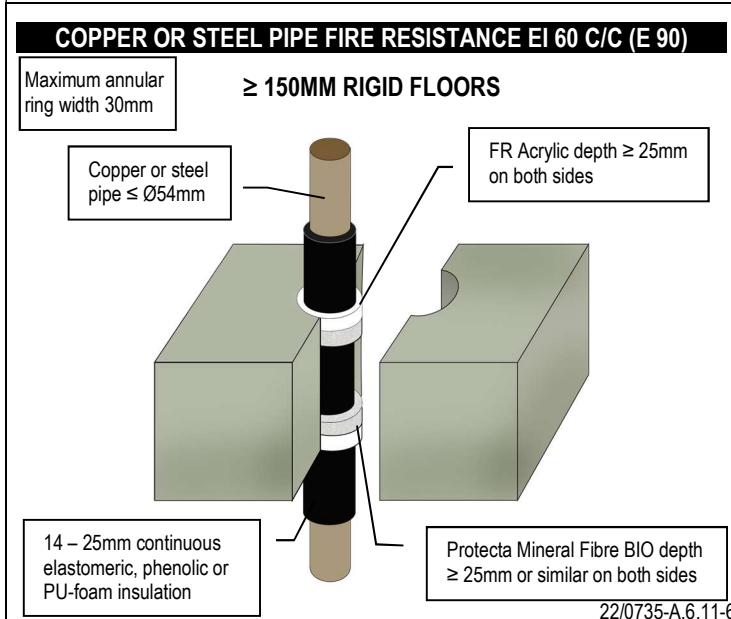
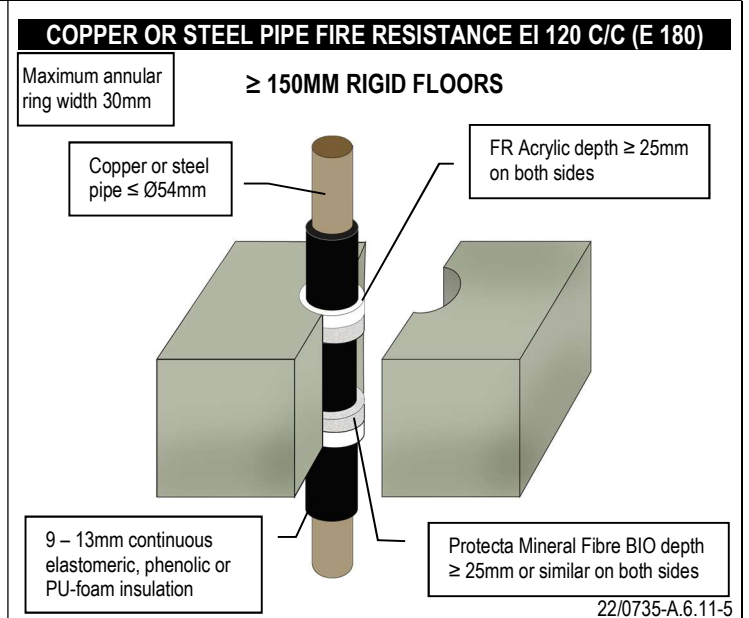
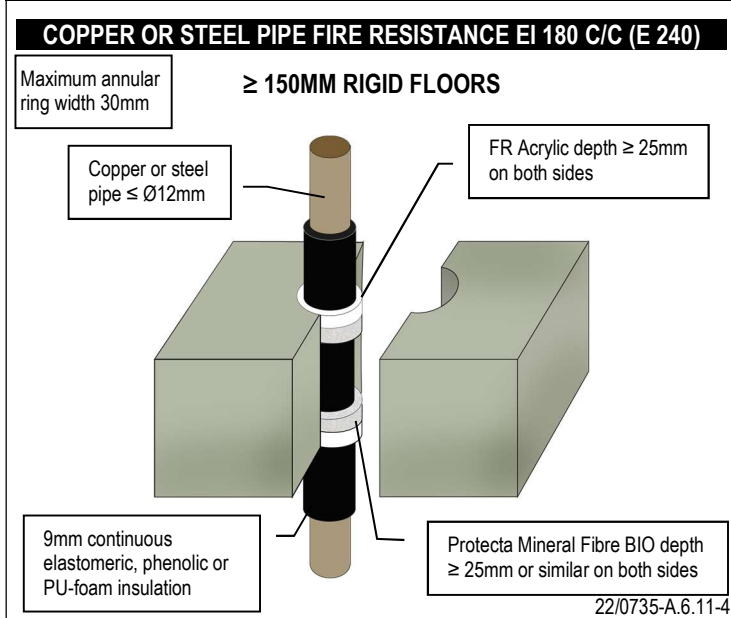
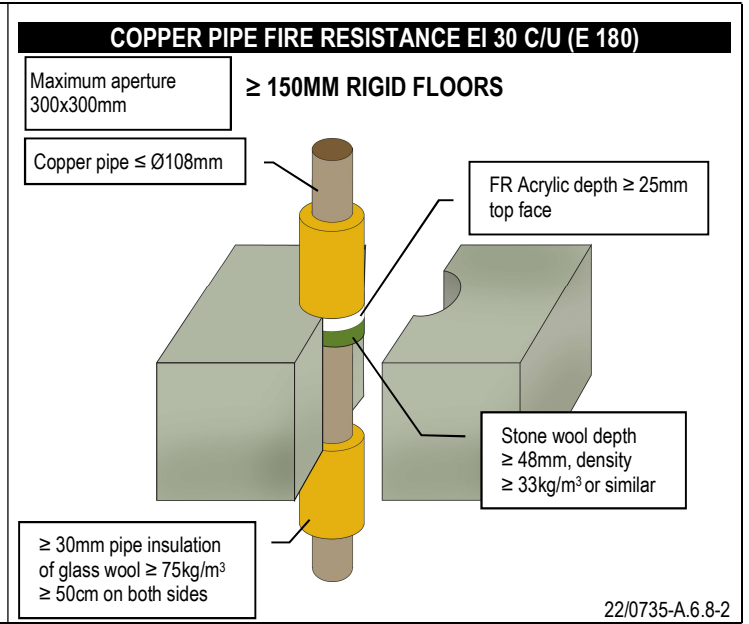
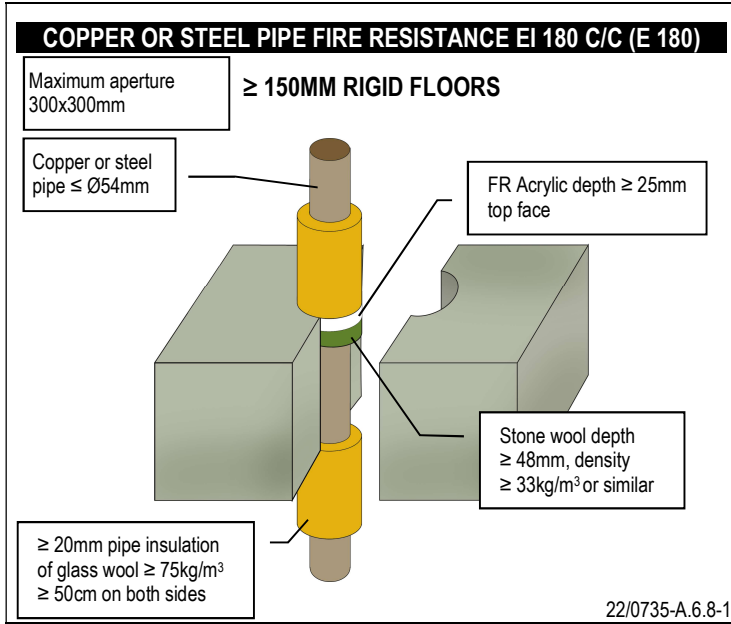

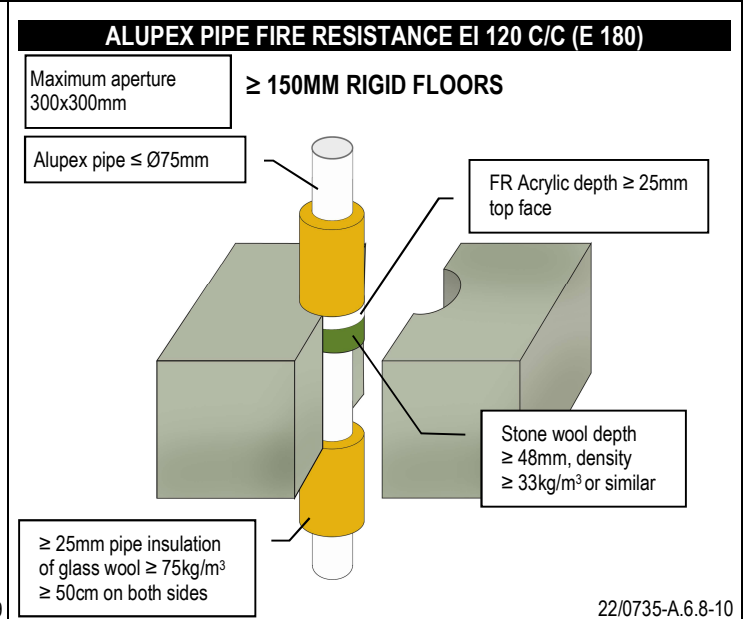
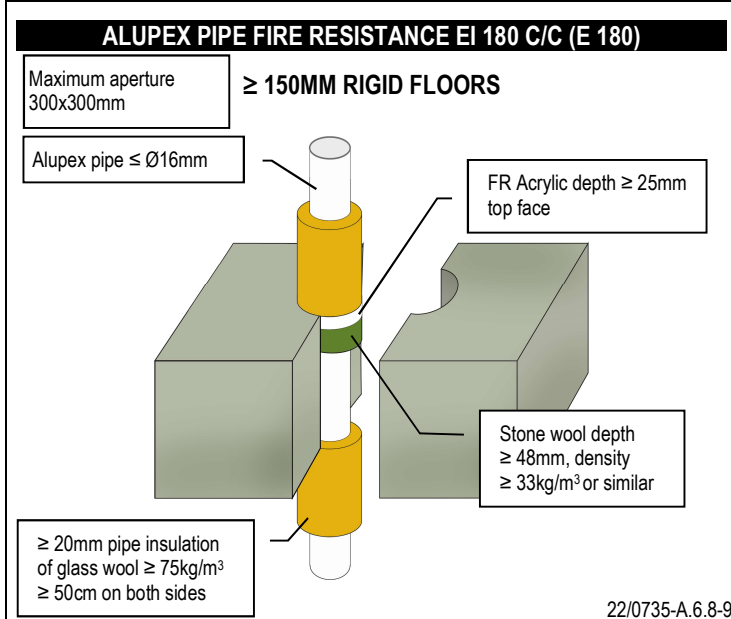
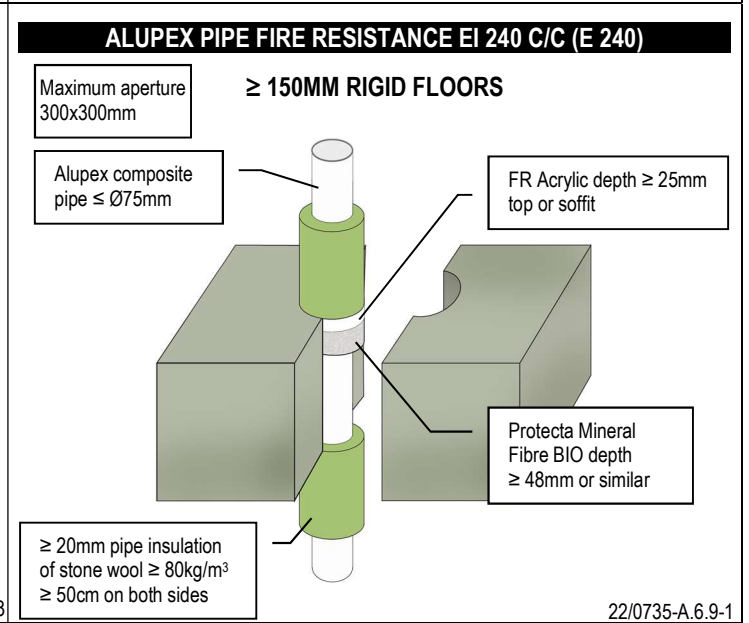
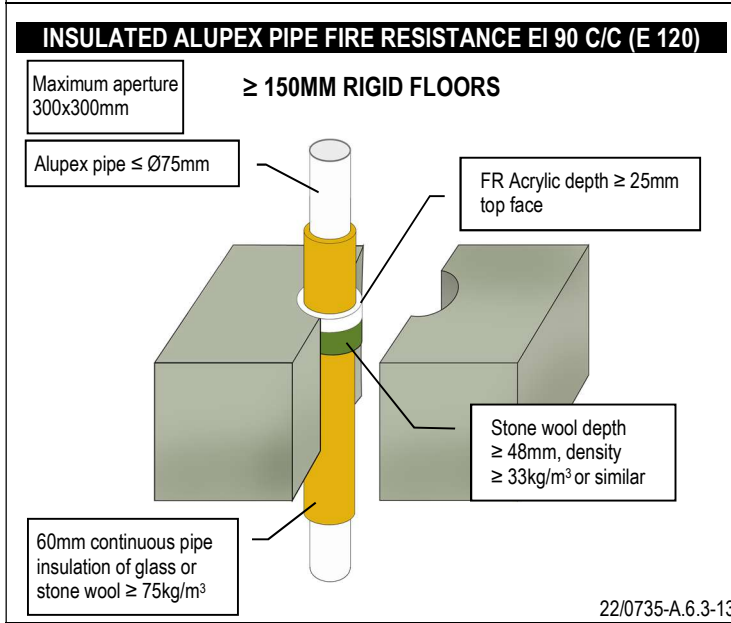
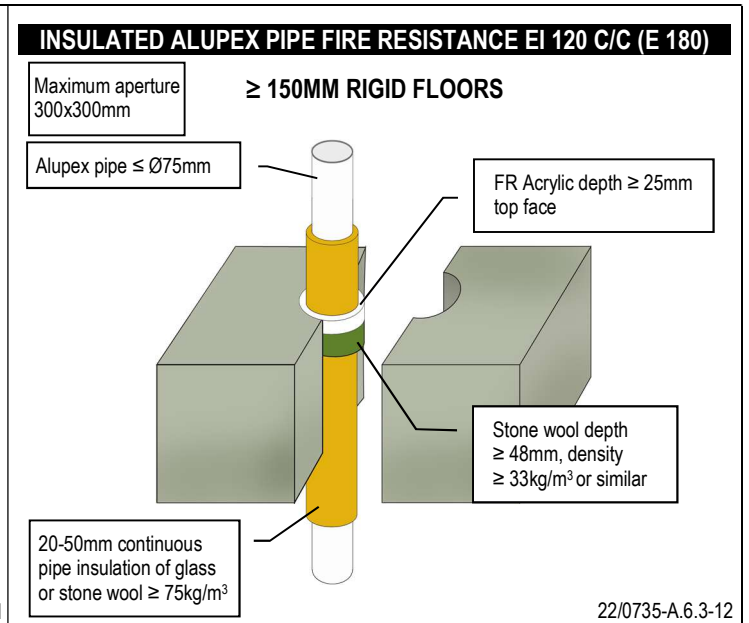
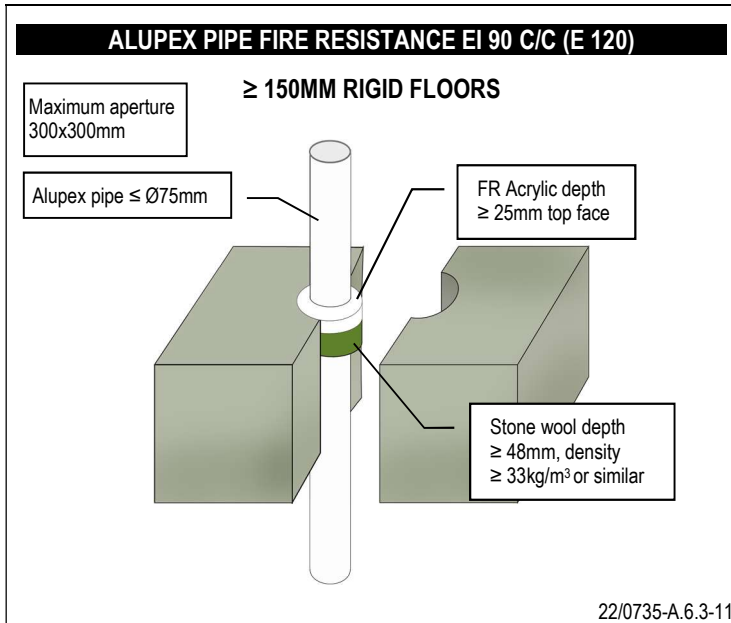

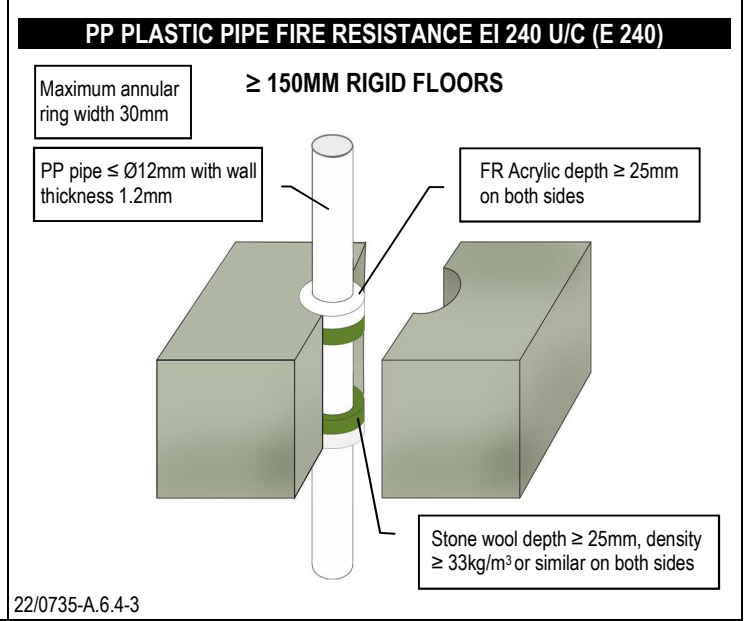
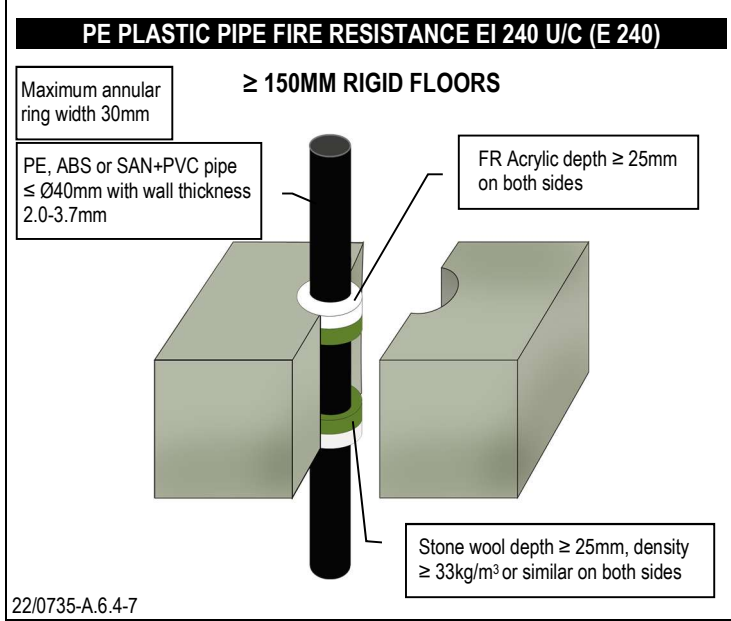
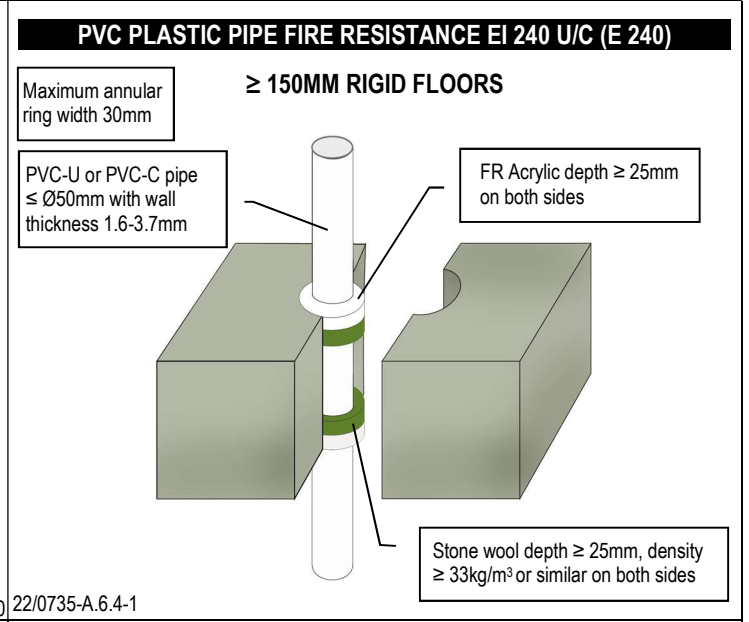
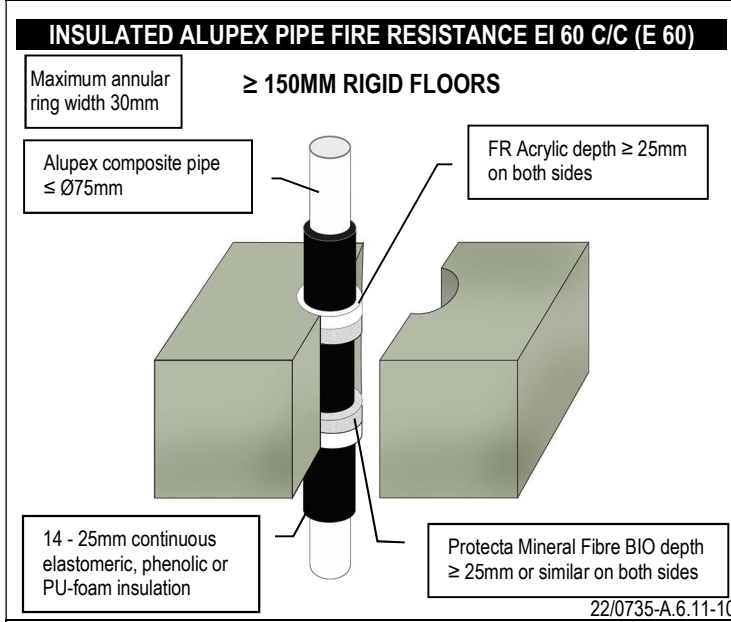
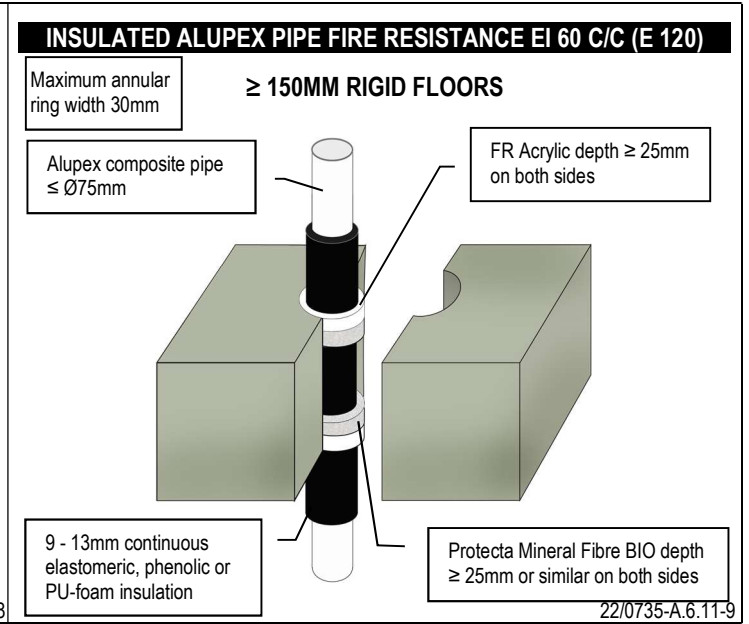
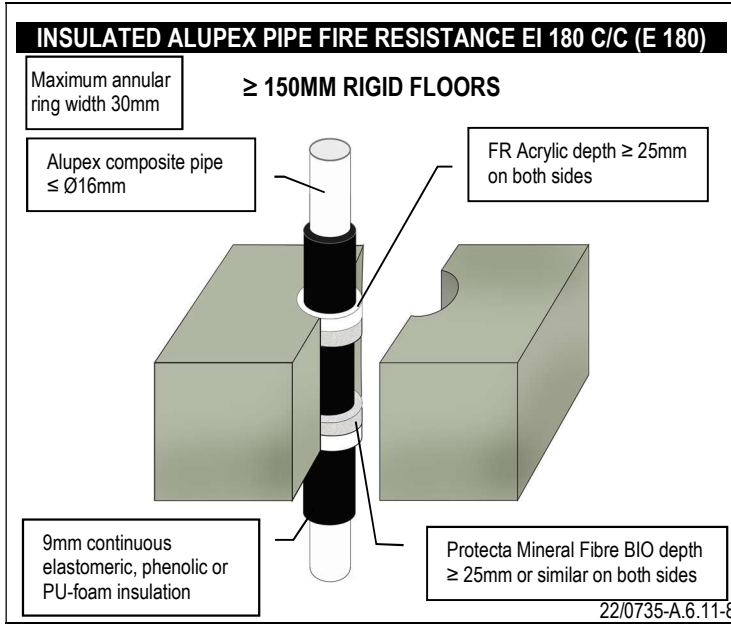

**PP PLASTIC PIPE FIRE RESISTANCE EI 180 U/C (E 180)**

Maximum annular ring width 30mm

**≥ 150MM RIGID FLOORS**

PP pipe ≤ Ø40mm with wall thickness 1.2-3.7mm

FR Acrylic depth ≥ 25mm on both sides

Stone wool depth ≥ 25mm, density ≥ 33kg/m³ or similar on both sides

22/0735-A.6.4-4

**PP PLASTIC PIPE FIRE RESISTANCE EI 90 U/C (E 90)**

Maximum annular ring width 30mm

**≥ 150MM RIGID FLOORS**

PP pipe ≤ Ø75mm with wall thickness 1.2-6.8mm

FR Acrylic depth ≥ 25mm on both sides

Stone wool depth ≥ 25mm, density ≥ 33kg/m³ or similar on both sides

22/0735-A.6.4-5

**AQUATECHNIK PIPE FIRE RESISTANCE EI 120 C/C (E 120)**

Maximum annular ring width 30mm

**≥ 150MM RIGID FLOORS**

Aquatechnik Faser Fiber-T pipe ≤ Ø40mm

FR Acrylic depth ≥ 25mm top face

Stone wool depth ≥ 48mm, density ≥ 33kg/m³ or similar

22/0735-A.6.3-14

**POLYBUTYLENE PIPE FIRE RESISTANCE EI 240 C/C (E 240)**

Maximum annular ring width 30mm

**≥ 150MM RIGID FLOORS**

Polybutylene pipe ≤ Ø28mm

FR Acrylic depth ≥ 15mm on both sides

Stone wool depth ≥ 25mm, density ≥ 33kg/m³ or similar on both sides

22/0735-A.6.4-12

**PEX PIPE-IN-PIPE SYSTEM FIRE RESISTANCE EI 90 C/C (E 90)**

Maximum annular ring width 30mm

**≥ 150MM RIGID FLOORS**

PEX pipe ≤ Ø25mm

FR Acrylic depth ≥ 25mm top face

Protecta Mineral Fibre BIO depth ≥ 48mm or similar

22/0735-A.6.7-3

**PEX PIPE-IN-PIPE SYSTEM FIRE RESISTANCE EI 240 C/C (E 240)**

Maximum annular ring width 30mm

**≥ 150MM RIGID FLOORS**

PEX pipe ≤ Ø44mm

FR Acrylic depth ≥ 25mm on both sides

Stone wool depth ≥ 25mm, density ≥ 33kg/m³ or similar on both sides

22/0735-A.6.4-10

**PEX PIPE-IN-PIPE SYSTEM FIRE RESISTANCE EI 60 C/C (E 60)**

Maximum annular ring width 30mm

**≥ 150MM RIGID FLOORS**

PEX pipe ≤ Ø25mm insulated with 9mm thick polyethylene foam

FR Acrylic depth ≥ 25mm on both sides

Stone wool depth ≥ 25mm, density ≥ 33kg/m³ or similar on both sides

22/0735-A.6.4-11

**PVC CONDUIT FIRE RESISTANCE EI 240 U/C (E 240)**

Maximum annular ring width 30mm

**≥ 150MM RIGID FLOORS**

PVC-U & PVC-C pipe ≤ Ø40mm with wall thickness 1.6-3.7mm

FR Acrylic depth ≥ 25mm on both sides

Cables ≤ Ø21mm single or in a bundle

Stone wool depth ≥ 25mm, density ≥ 33kg/m³ or similar on both sides

22/0735-A.6.4-2

**PE CONDUIT FIRE RESISTANCE EI 180 U/C (E 180)**

Maximum annular ring width 30mm

**≥ 150MM RIGID FLOORS**

PE, ABS & SAN+PVC pipe ≤ Ø40mm with wall thickness 2.0-3.7mm

FR Acrylic depth ≥ 25mm on both sides

Cables ≤ Ø21mm single or in a bundle

Stone wool depth ≥ 25mm, density ≥ 33kg/m³ or similar on both sides

22/0735-A.6.4-8

**PP CONDUIT FIRE RESISTANCE EI 180 U/C (E 180)**

Maximum annular ring width 30mm

**≥ 150MM RIGID FLOORS**

PP pipe ≤ Ø40mm with wall thickness 1.2-3.7mm

FR Acrylic depth ≥ 25mm on both sides

Cables ≤ Ø21mm single or in a bundle

Stone wool depth ≥ 25mm, density ≥ 33kg/m³ or similar on both sides

22/0735-A.6.4-6

**CABLES FIRE RESISTANCE EI 30 (E 30)**

Maximum aperture 300x300mm

**≥ 228MM FLEXIBLE FLOORS**

FR Acrylic depth ≥ 18mm top face & ≥ 12.5mm soffit face

Cables ≤ Ø80mm single or in a bundle ≤ Ø100mm

22/0735-A.7.1-2

**CABLES FIRE RESISTANCE EI 60 (E 60)**

Maximum aperture 150x150mm

**≥ 240MM FLEXIBLE FLOORS**

FR Acrylic depth ≥ 18mm top face & ≥ 25mm soffit face

Cables ≤ Ø80mm single or in a bundle ≤ Ø100mm

22/0735-A.7.5-2

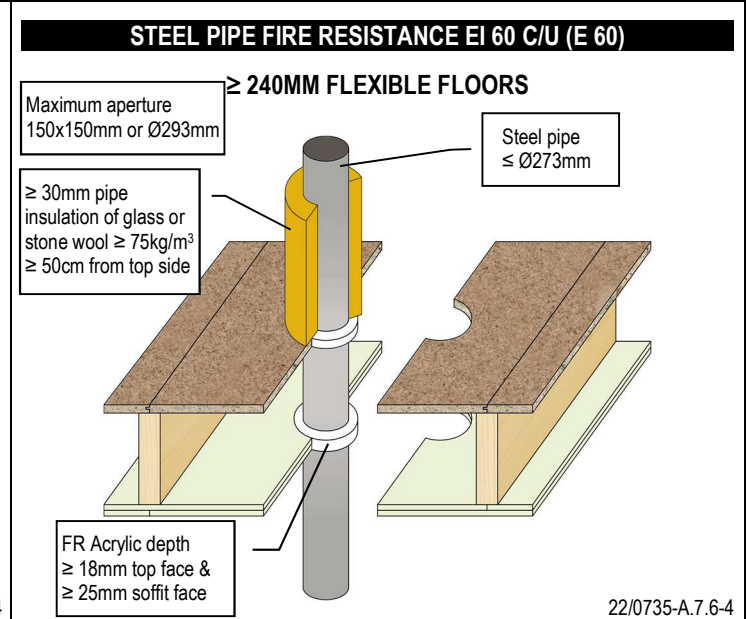
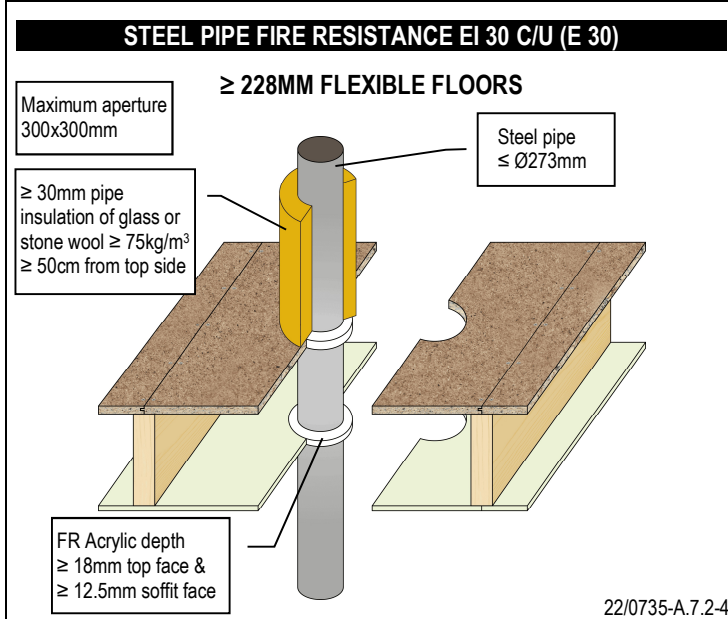
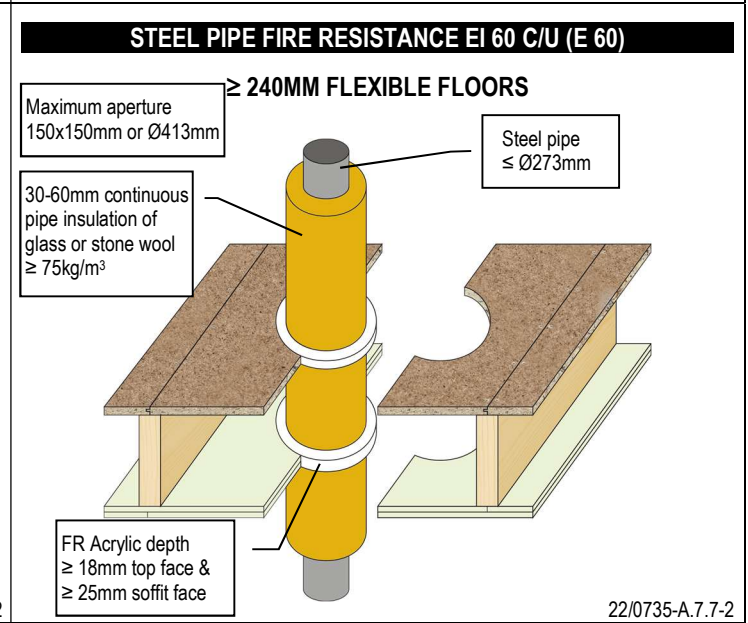
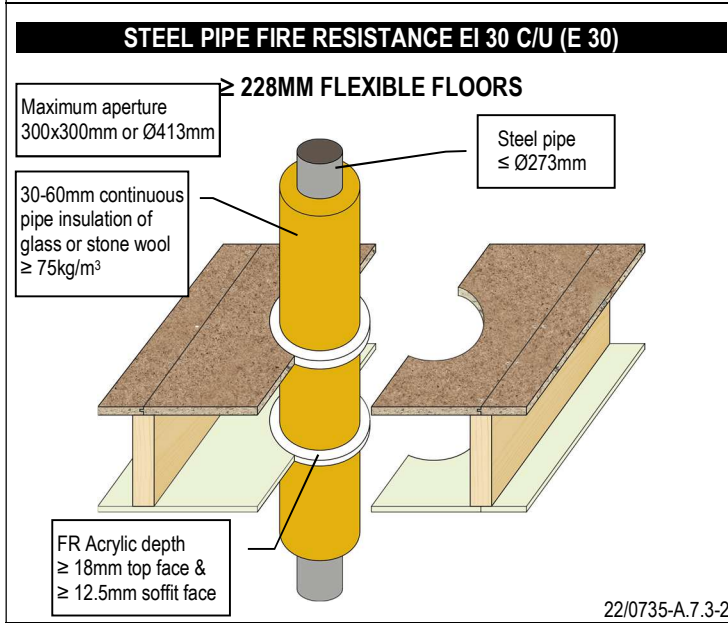
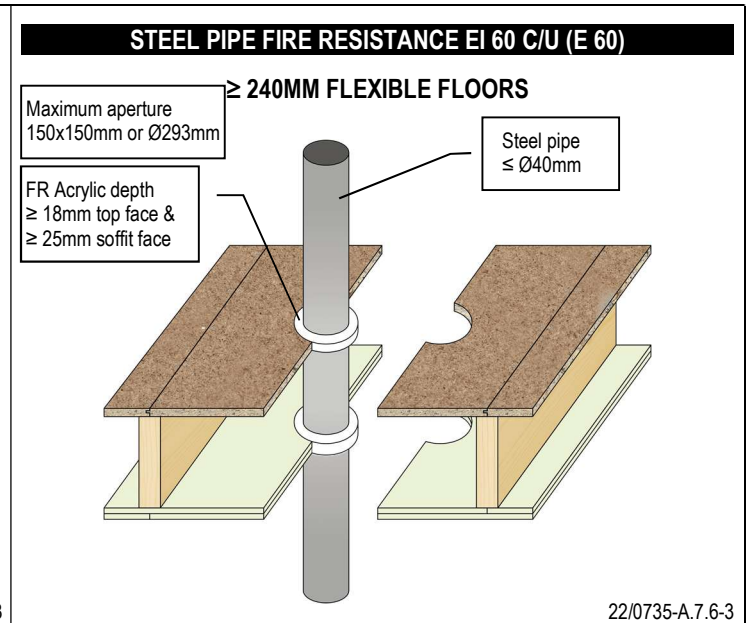
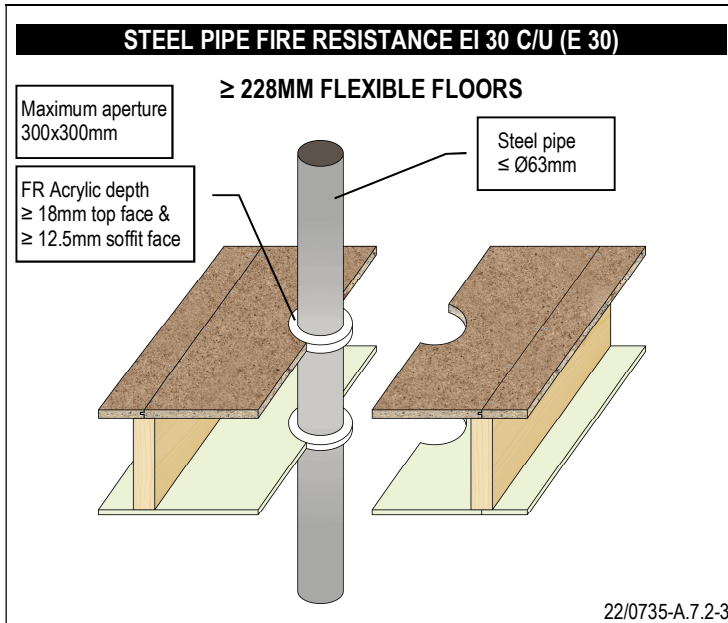

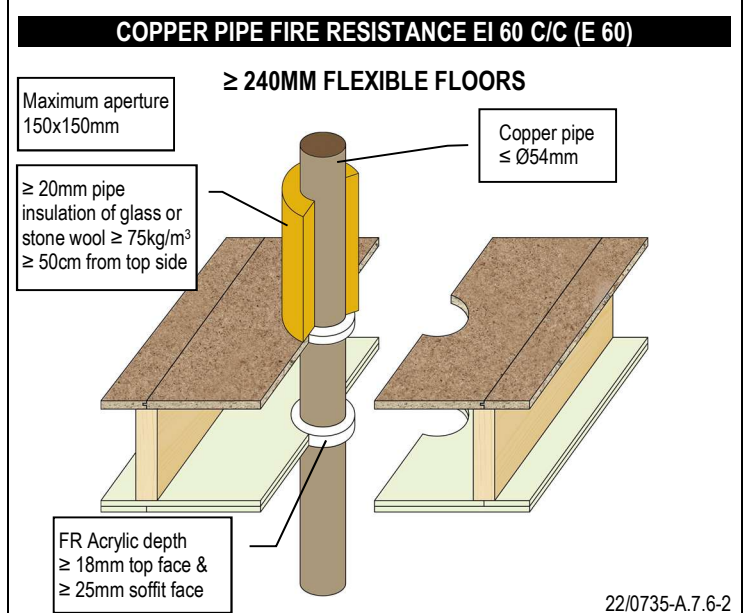
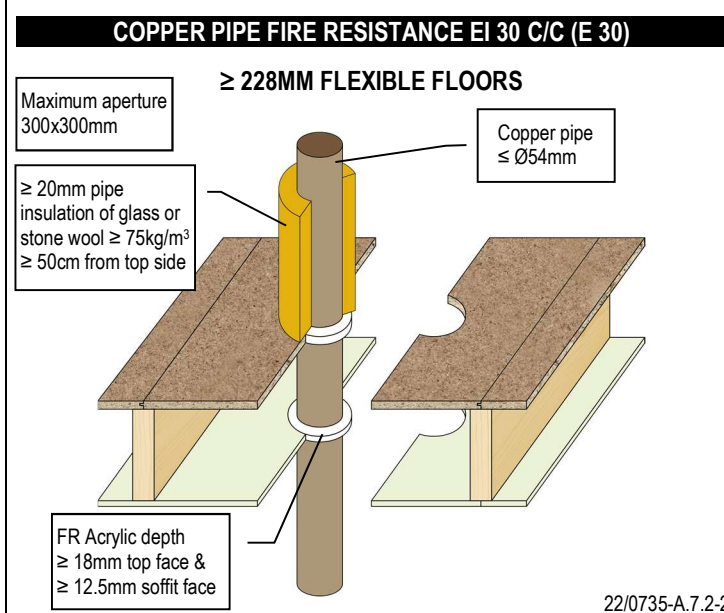
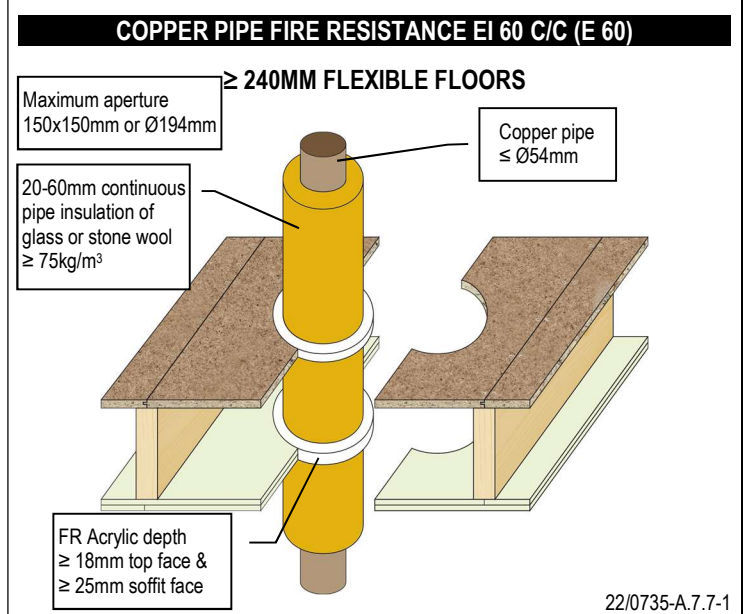
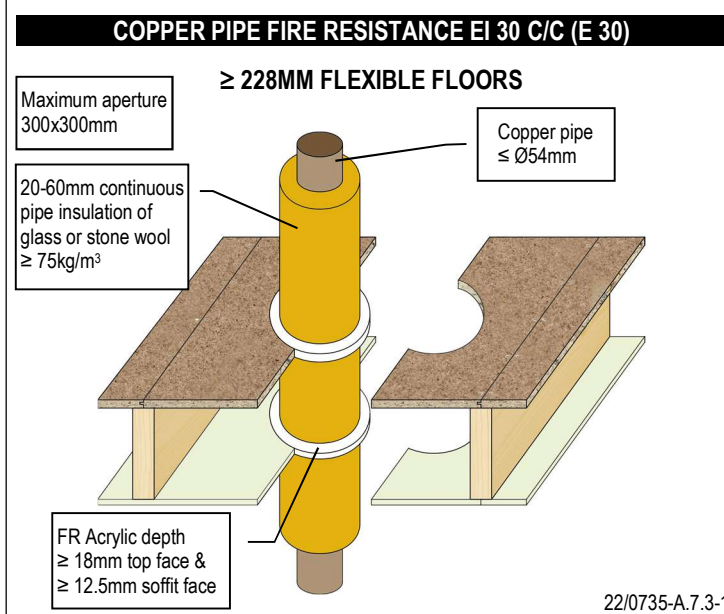
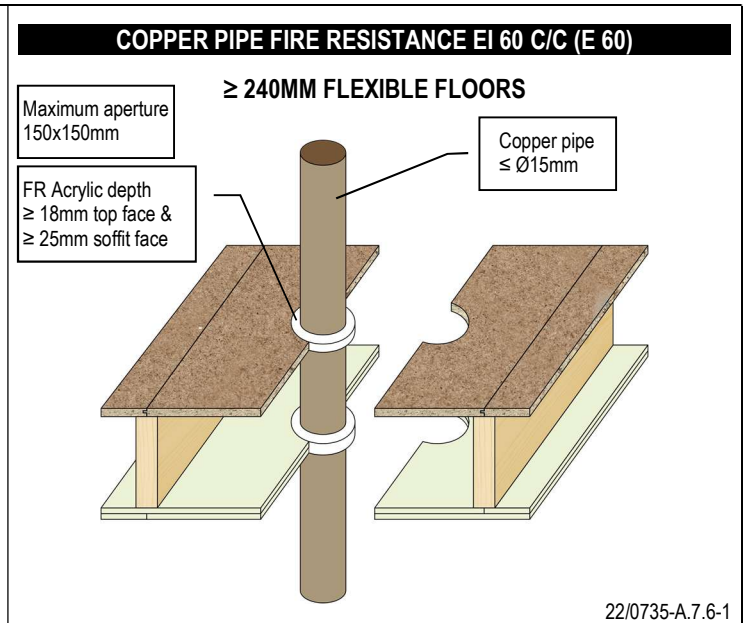
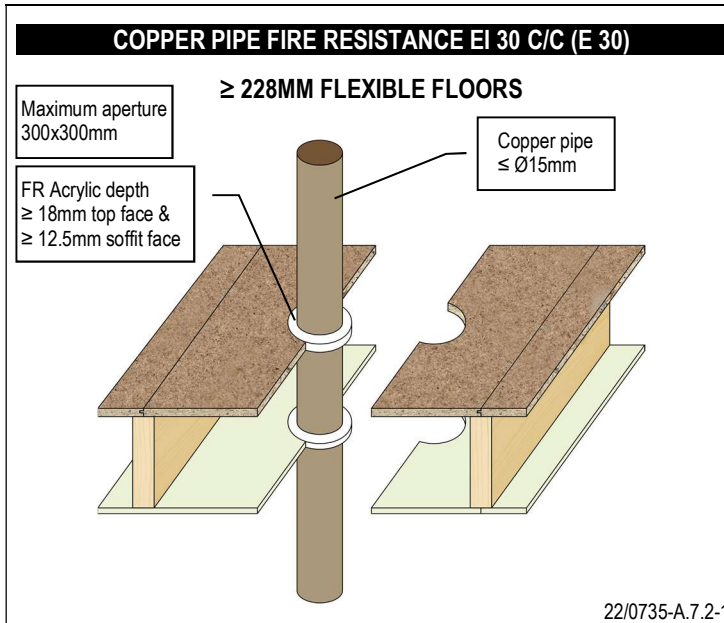

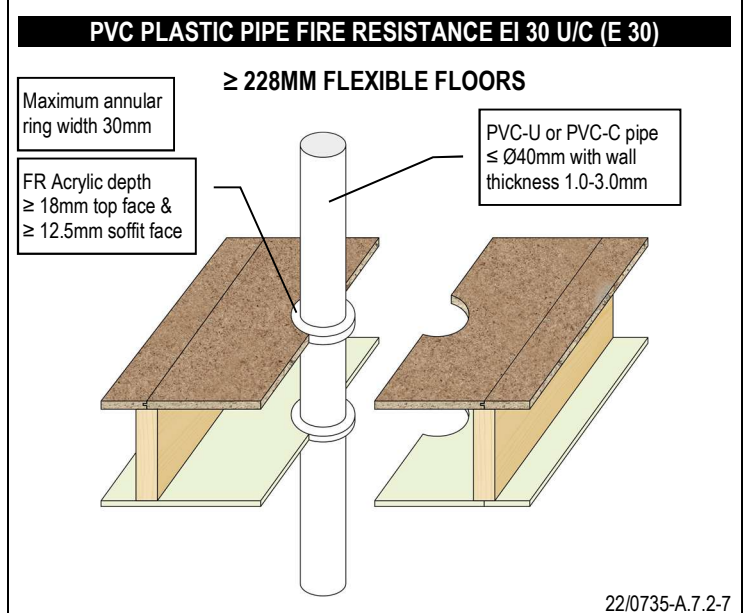
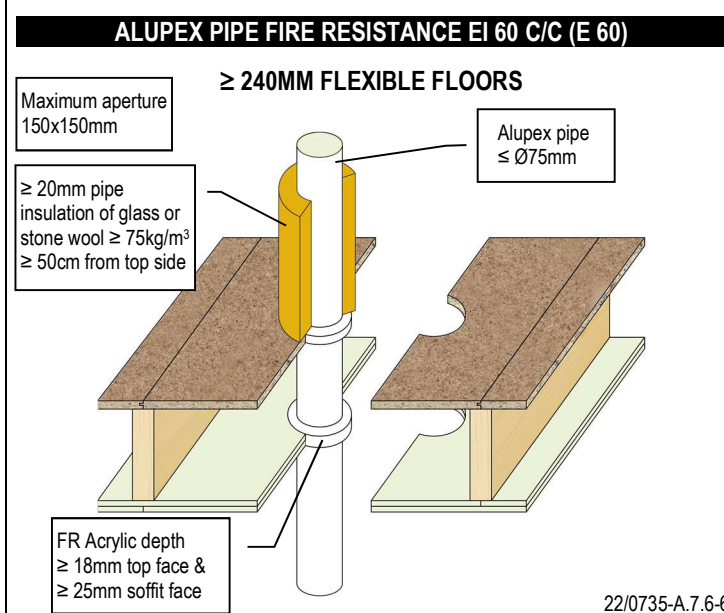
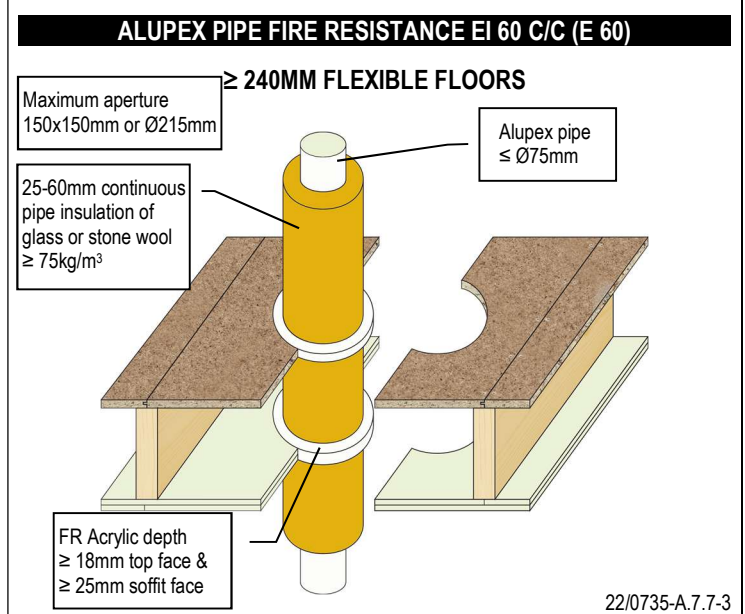
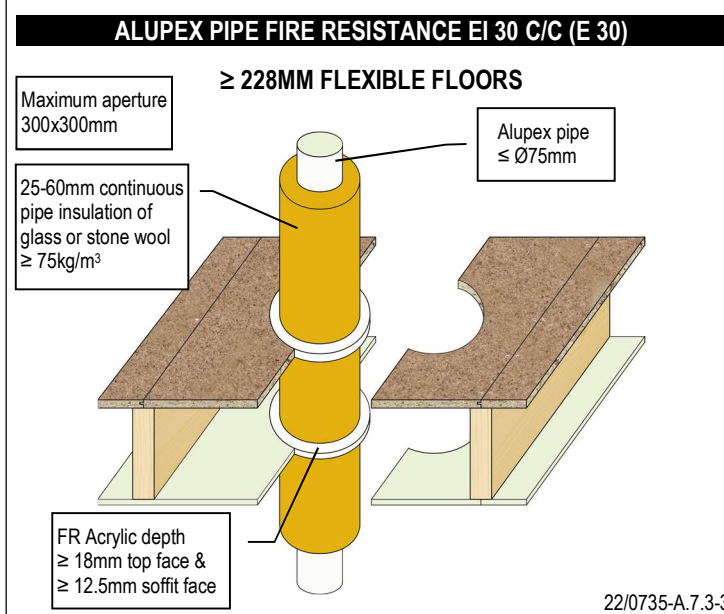
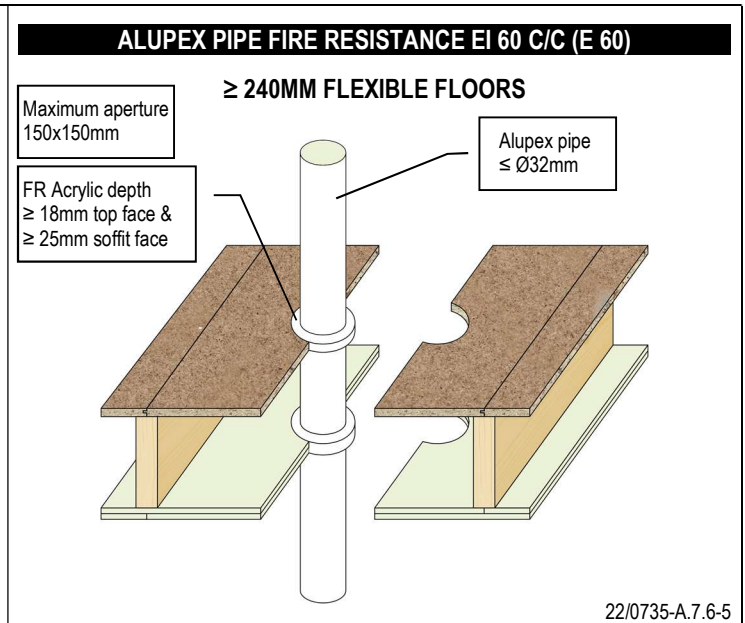
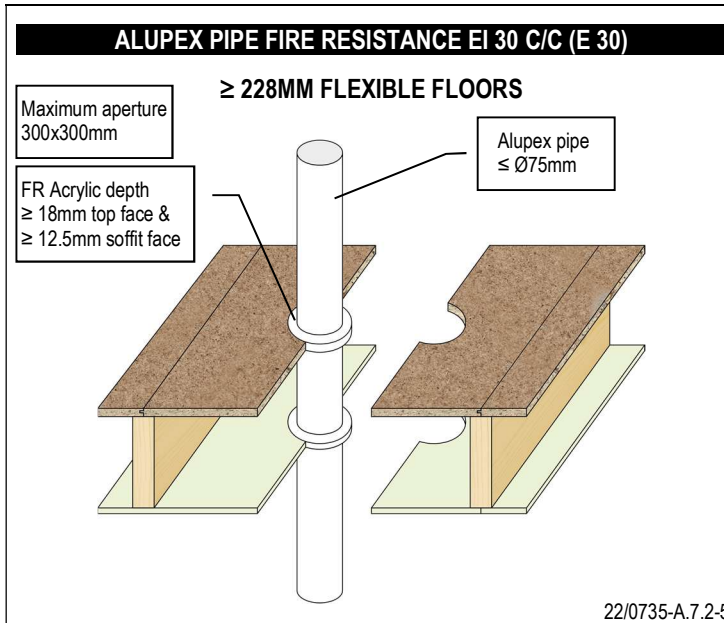

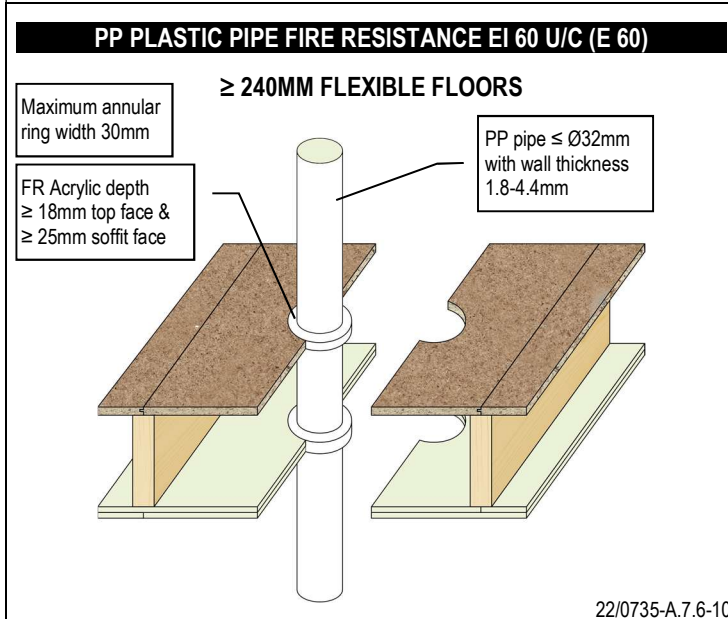
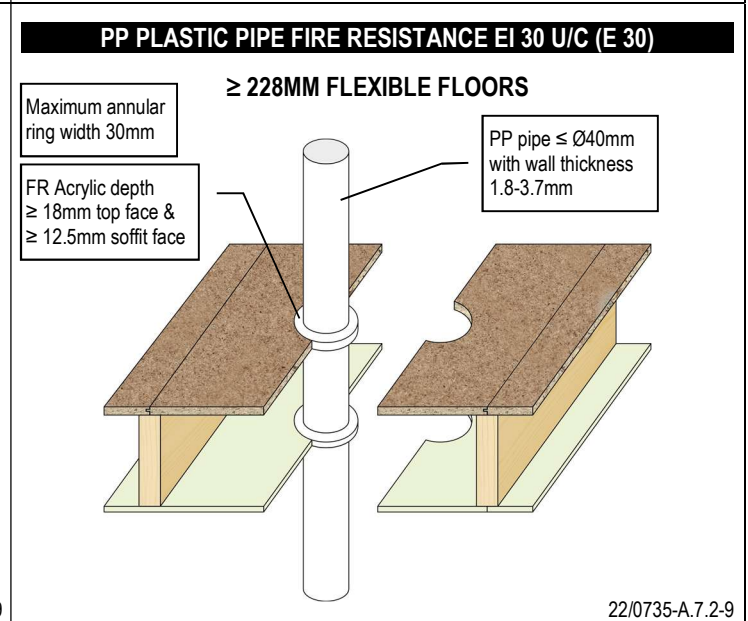
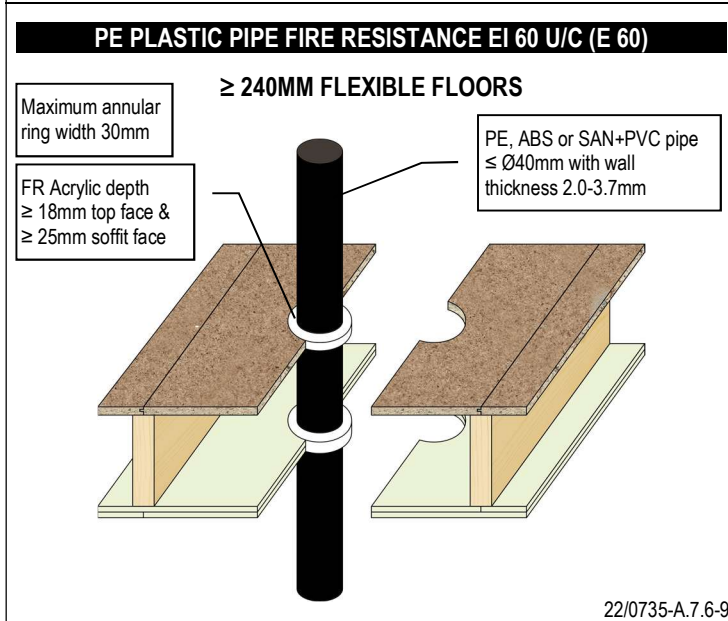
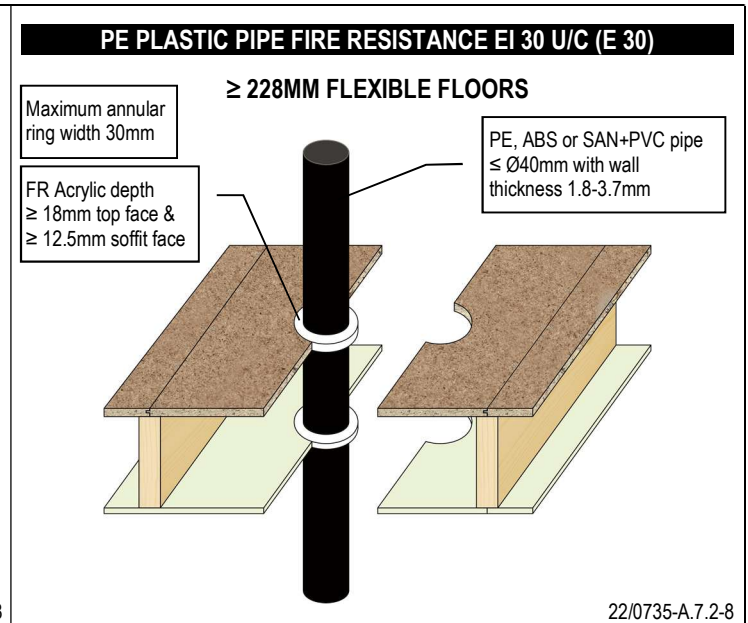
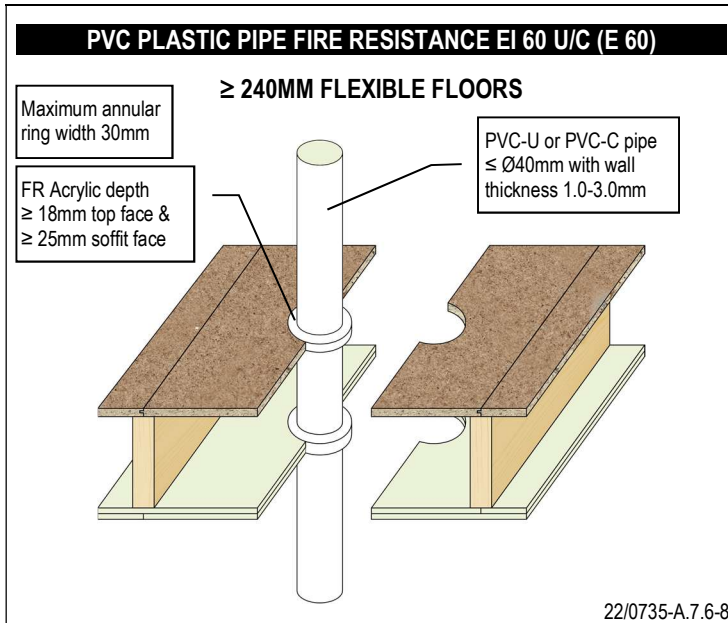

**PLASTIC PIPE FIRE RESISTANCE EI 30 (E 30)**

**≥ 228MM FLEXIBLE FLOORS**

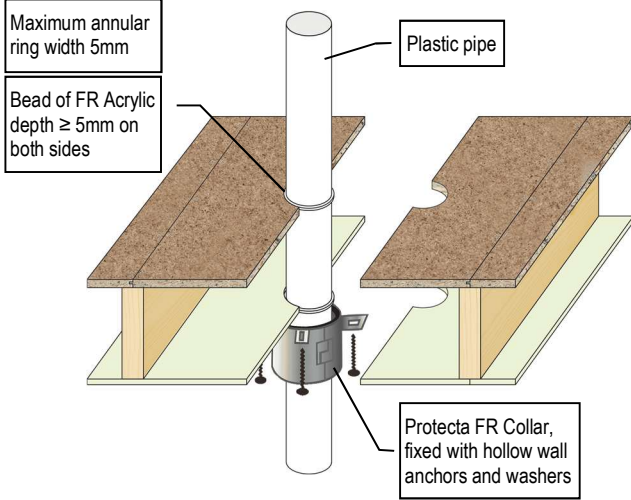

| Pipe          | Pipe W/T     | Collar Ø x h     | Config |
|---------------|--------------|------------------|--------|
| ≤ Ø 50mm PVC  | 2.4mm        | ≤ 50mm x ≥ 30mm  | U/U    |
| ≤ Ø 50mm PE   | 3.0 – 4.6mm  | ≤ 50mm x ≥ 30mm  | U/U    |
| ≤ Ø 50mm PP   | 1.8 – 4.6mm  | ≤ 50mm x ≥ 30mm  | U/U    |
| ≤ Ø 110mm PVC | 2.4 – 6.6mm  | ≤ 110mm x ≥ 30mm | U/U    |
| ≤ Ø 110mm PE  | 3.0 – 10.0mm | ≤ 110mm x ≥ 30mm | U/C    |
| ≤ Ø 110mm PE  | 3.0 – 10.0mm | ≤ 110mm x ≥ 50mm | U/U    |
| ≤ Ø 110mm PP  | 1.8 – 6.3mm  | ≤ 110mm x ≥ 30mm | U/C    |
| ≤ Ø 110mm PP  | 1.8 – 6.3mm  | ≤ 110mm x ≥ 50mm | U/U    |
| ≤ Ø 160mm PVC | 3.2 – 9.5mm  | ≤ 160mm x ≥ 60mm | U/C    |
| ≤ Ø 160mm PE  | 3.4 – 14.6mm | ≤ 160mm x ≥ 60mm | U/C    |
| ≤ Ø 160mm PP  | 4.2 – 14.6mm | ≤ 160mm x ≥ 60mm | U/C    |

If the annular gap is above 5mm, an oversized collar may be used with maximum size of Ø160mm, subject to an increase in sealant depth to minimum 18mm at top face and 12.5mm at soffit face

22/0735-A.7.4-1

**PLASTIC PIPE FIRE RESISTANCE EI 60 (E 60)**

**≥ 240MM FLEXIBLE FLOORS**

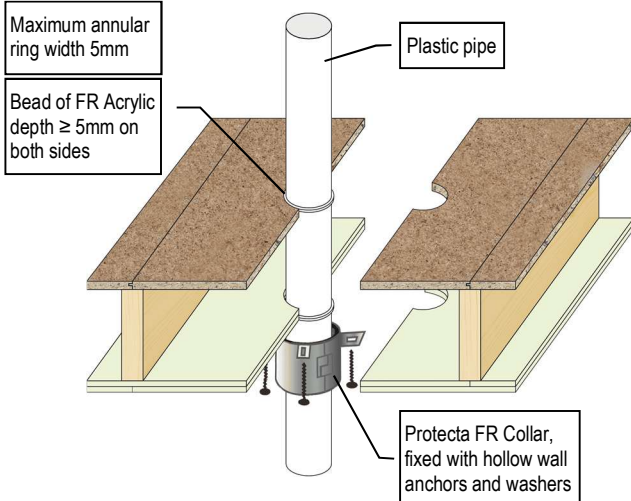

| Pipe          | Pipe W/T     | Collar Ø x h     | Config |
|---------------|--------------|------------------|--------|
| ≤ Ø 50mm PVC  | 2.4 – 3.7mm  | ≤ 50mm x ≥ 30mm  | U/U    |
| ≤ Ø 50mm PE   | 3.0 – 4.6mm  | ≤ 50mm x ≥ 30mm  | U/U    |
| ≤ Ø 50mm PP   | 1.8 – 4.6mm  | ≤ 50mm x ≥ 30mm  | U/U    |
| ≤ Ø 110mm PVC | 2.4 – 6.6mm  | ≤ 110mm x ≥ 30mm | U/U    |
| ≤ Ø 110mm PE  | 3.0 – 10.0mm | ≤ 110mm x ≥ 30mm | U/C    |
| ≤ Ø 110mm PE  | 3.0 – 10.0mm | ≤ 110mm x ≥ 50mm | U/U    |
| ≤ Ø 110mm PP  | 1.8 – 6.3mm  | ≤ 110mm x ≥ 30mm | U/C    |
| ≤ Ø 110mm PP  | 1.8 – 6.3mm  | ≤ 110mm x ≥ 50mm | U/U    |
| ≤ Ø 160mm PVC | 3.2 – 9.5mm  | ≤ 160mm x ≥ 60mm | U/C    |
| ≤ Ø 160mm PE  | 3.4 – 14.6mm | ≤ 160mm x ≥ 60mm | U/C    |
| ≤ Ø 160mm PP  | 4.2 – 14.6mm | ≤ 160mm x ≥ 60mm | U/C    |

If the annular gap is above 5mm, an oversized collar may be used with maximum size of Ø160mm, subject to an increase in sealant depth to minimum 18mm at top face and 25mm at soffit face

22/0735-A.7.8-1

**PLASTIC PIPES FIRE RESISTANCE EI 30 U/C (E 30)**

**≥ 228MM FLEXIBLE FLOORS**

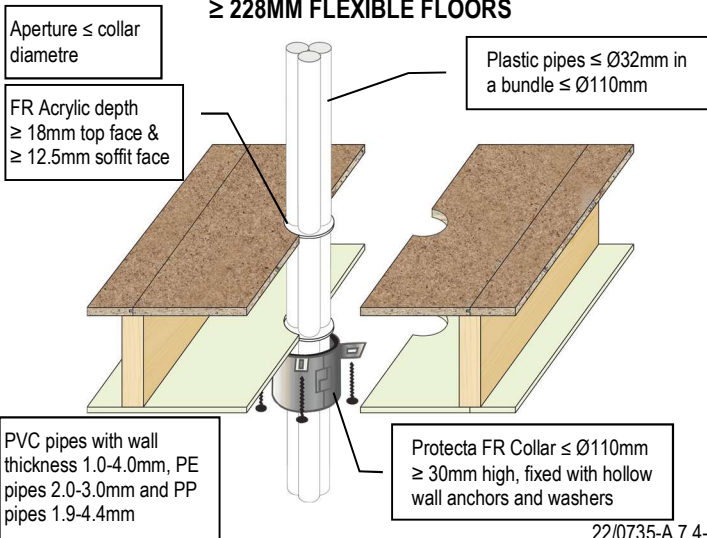

22/0735-A.7.4-4

**PLASTIC PIPES FIRE RESISTANCE EI 60 U/C (E 60)**

**≥ 240MM FLEXIBLE FLOORS**

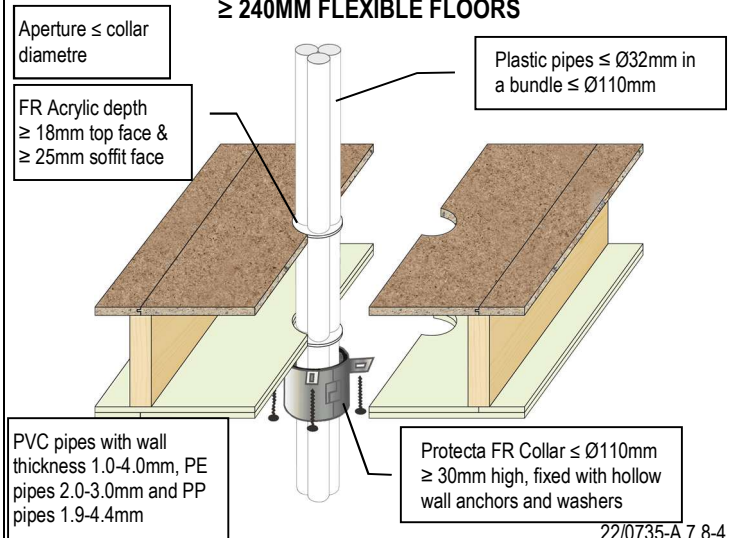

22/0735-A.7.8-4

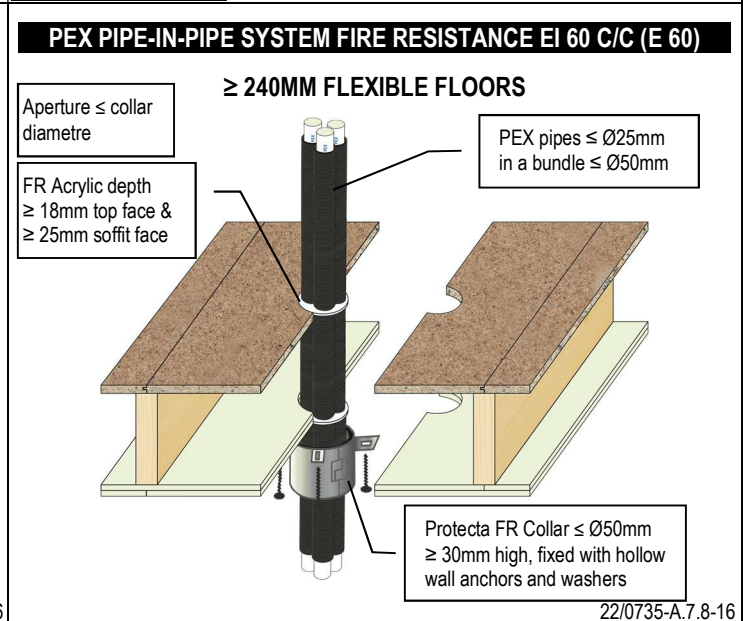
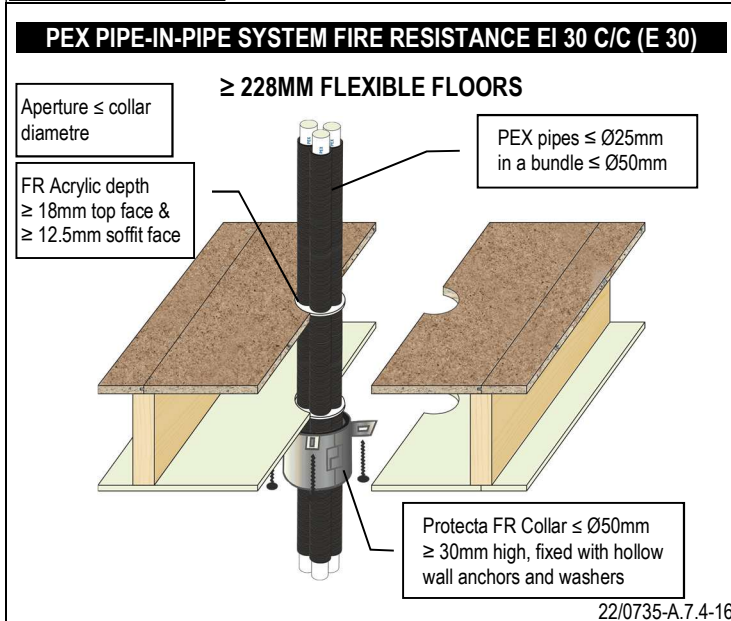
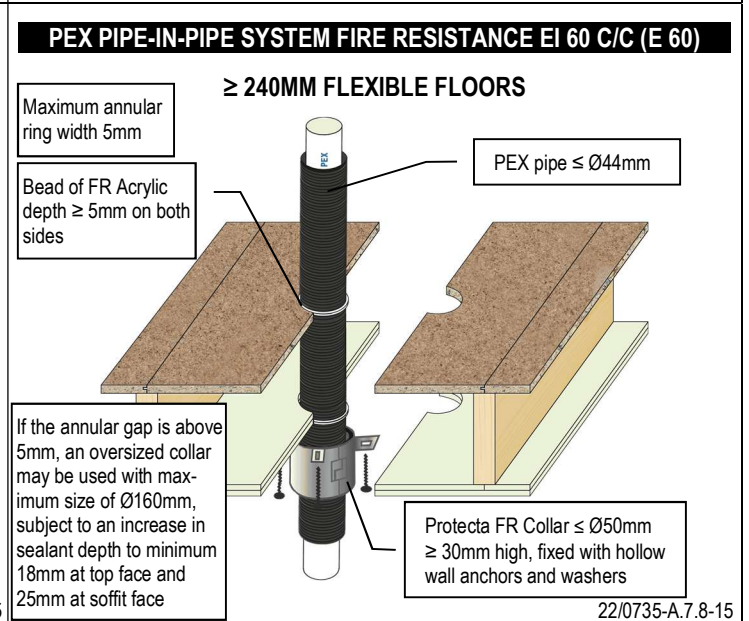
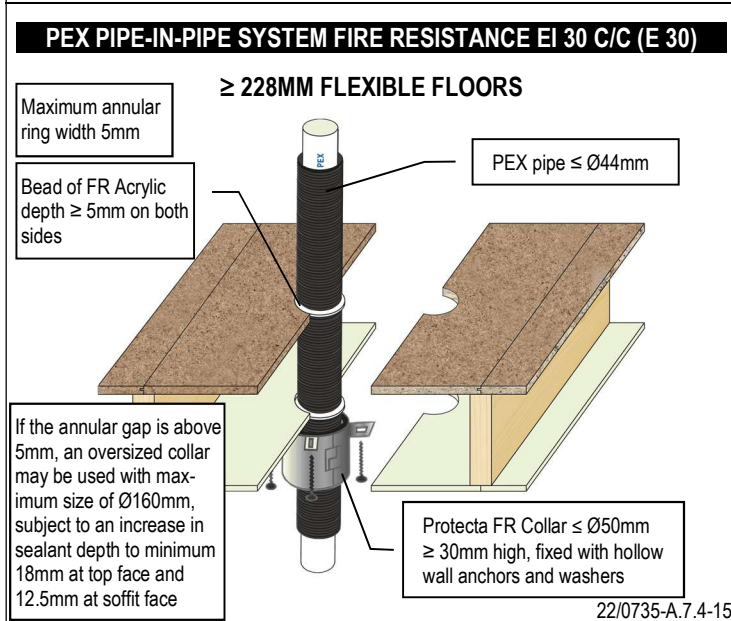
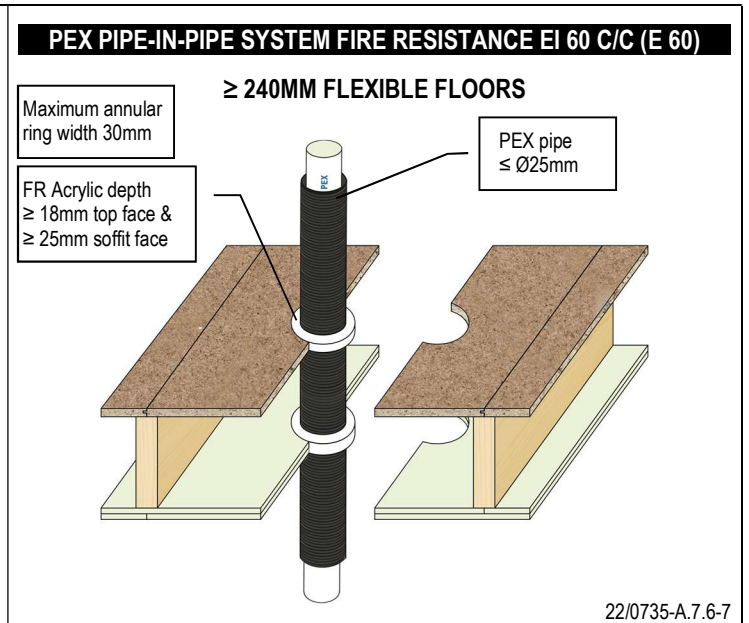
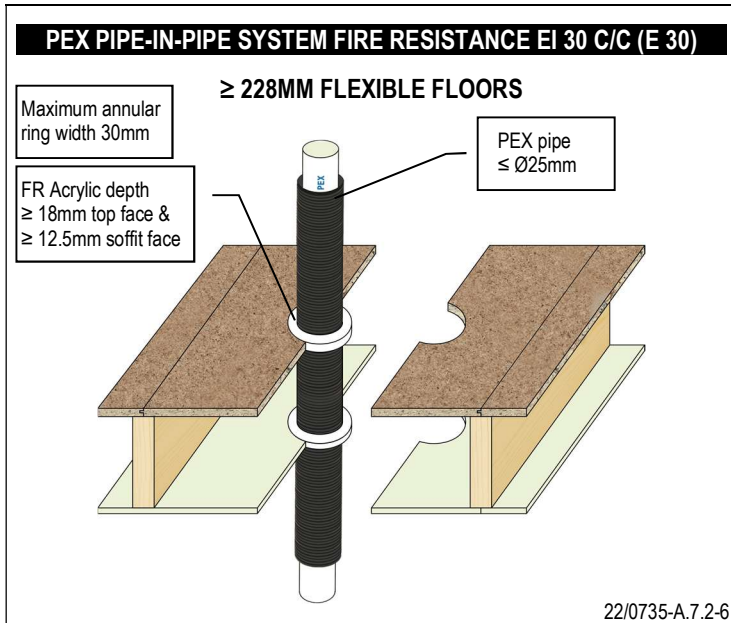

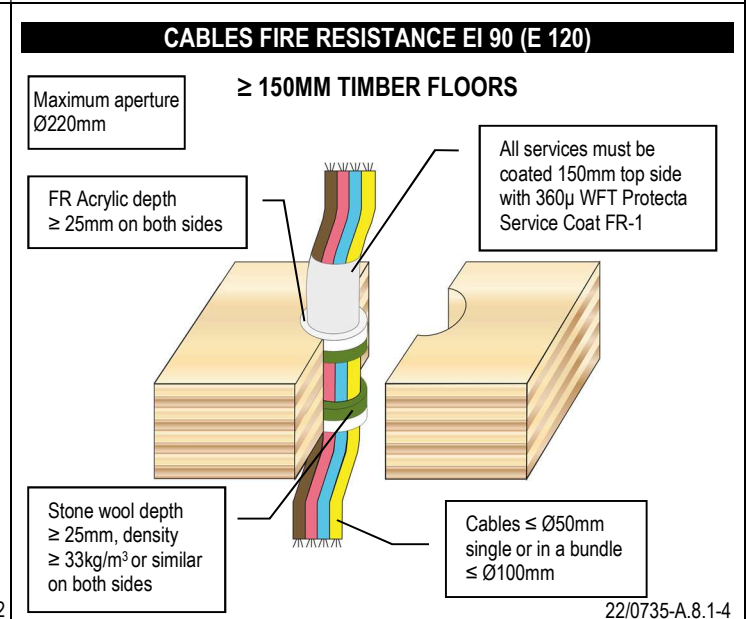
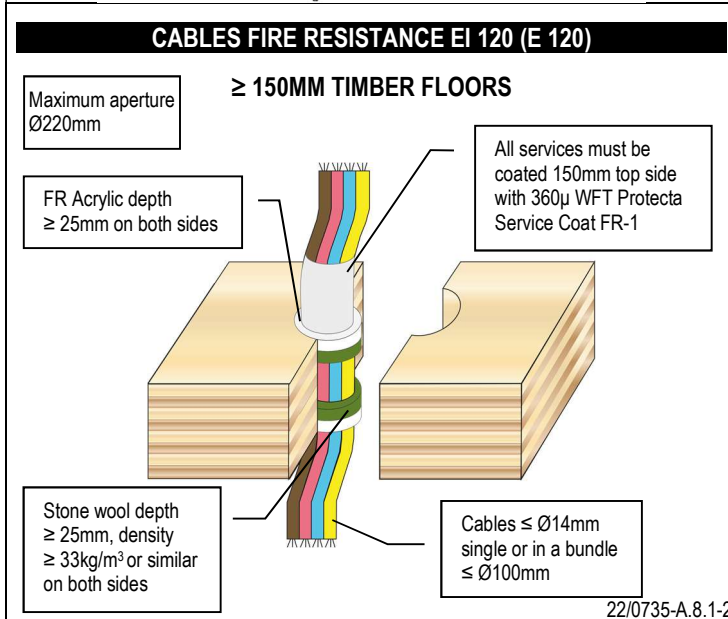
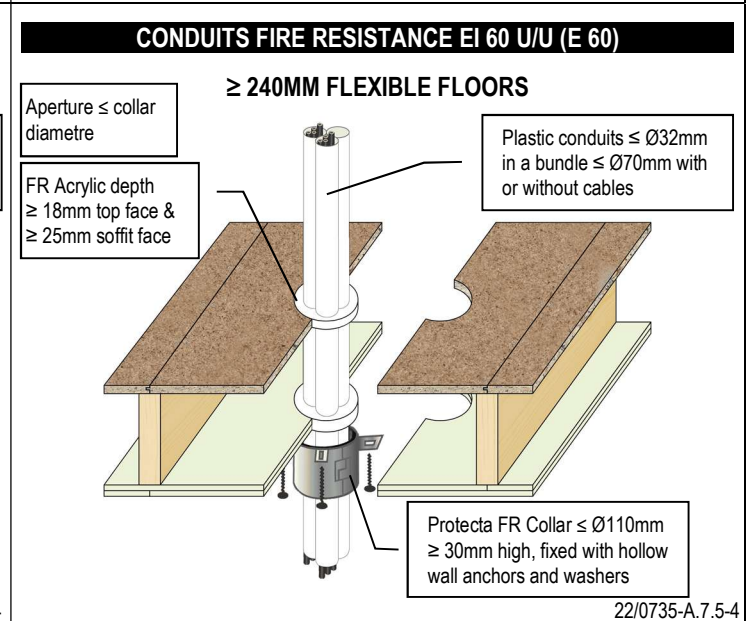
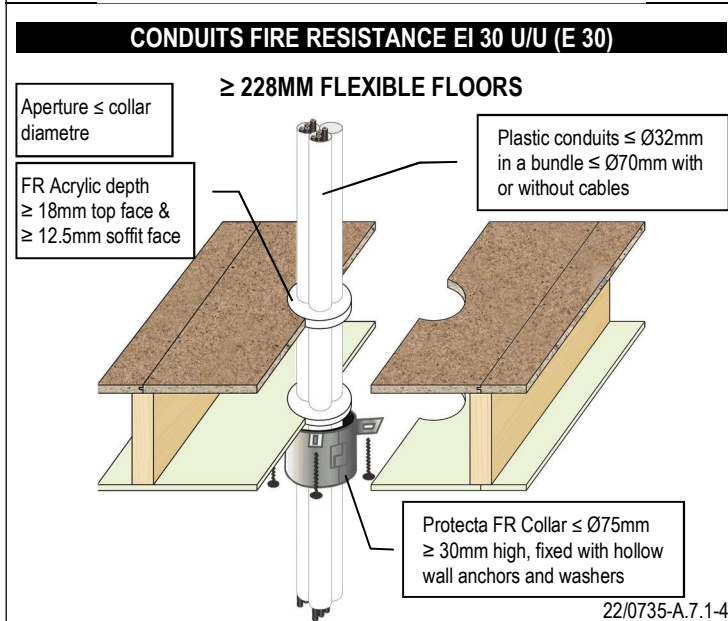
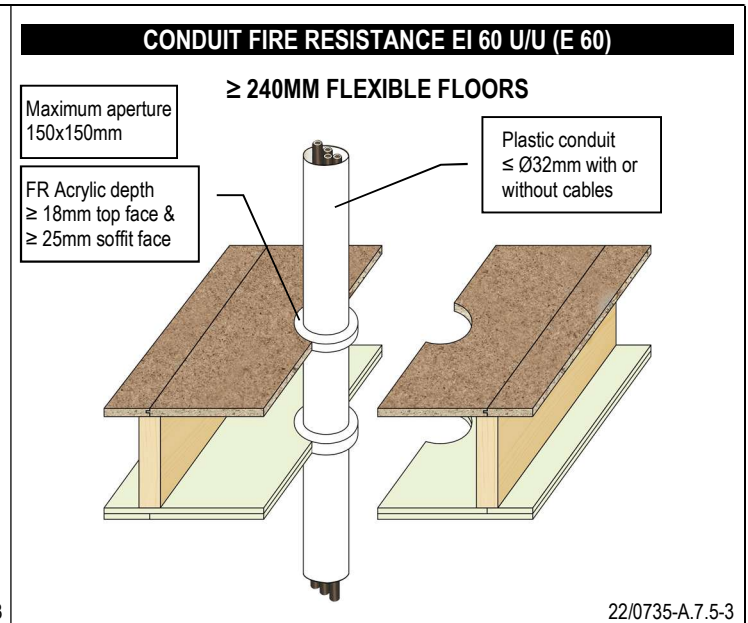
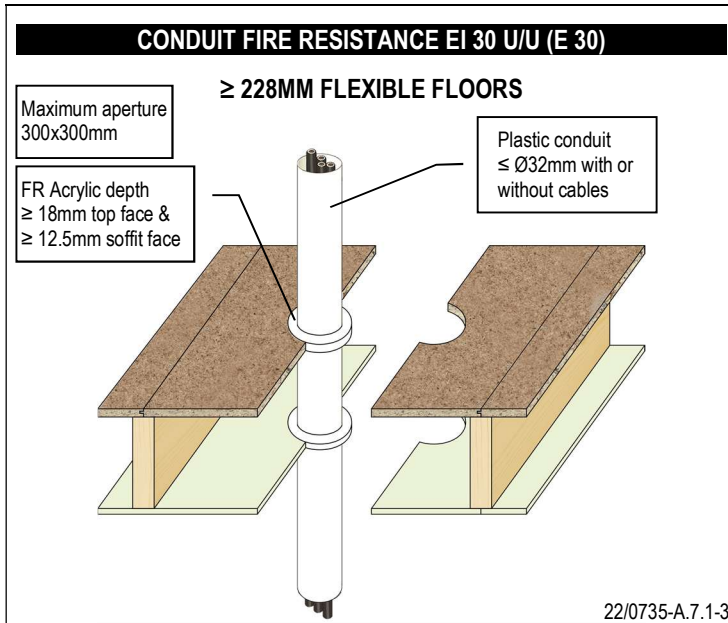

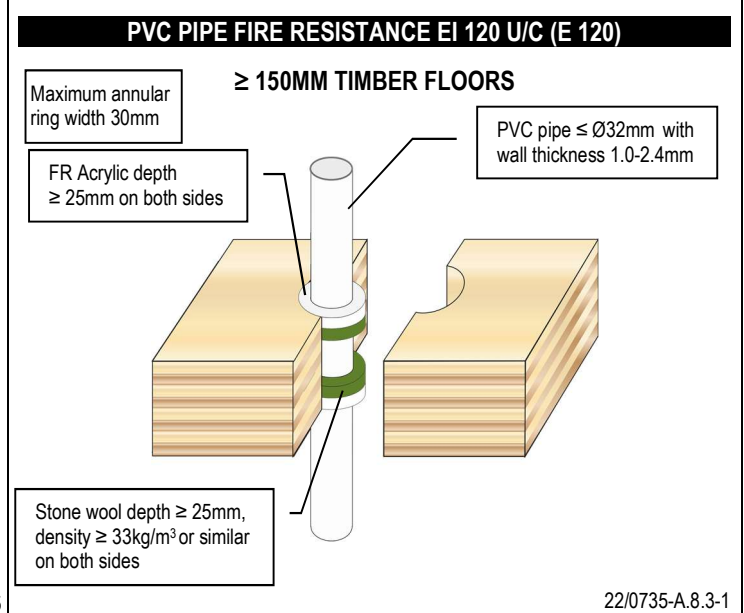
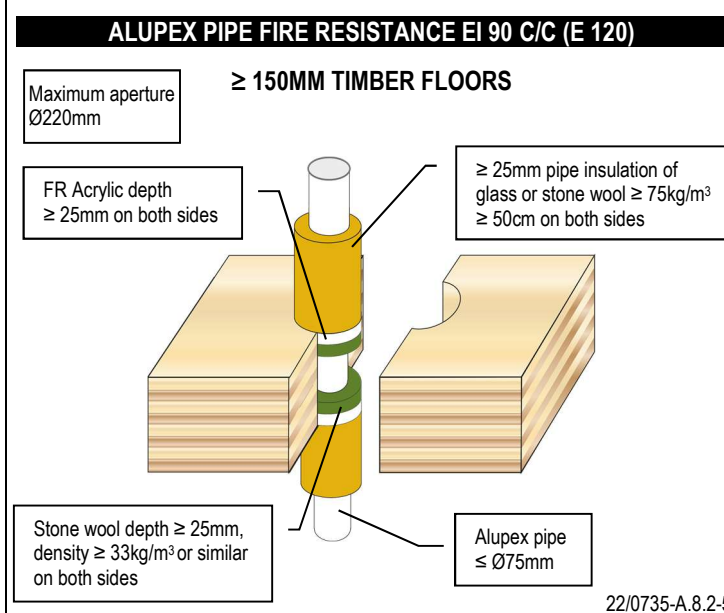
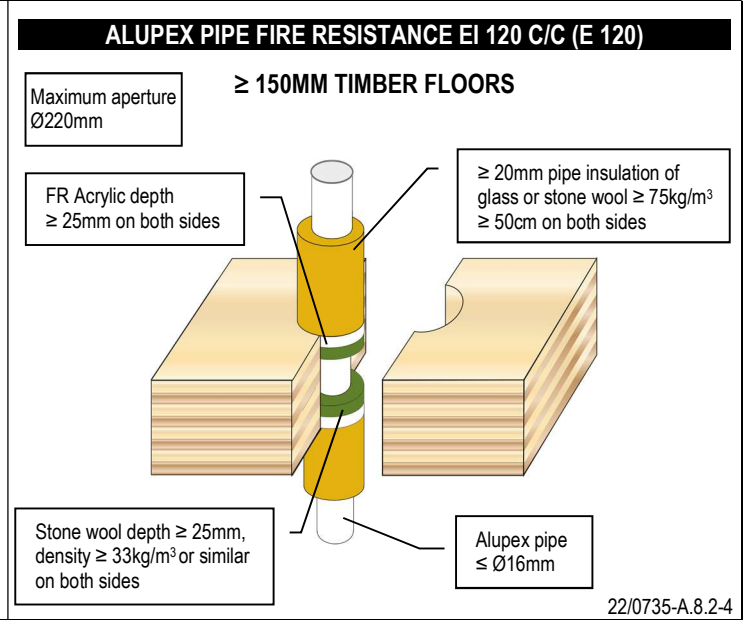
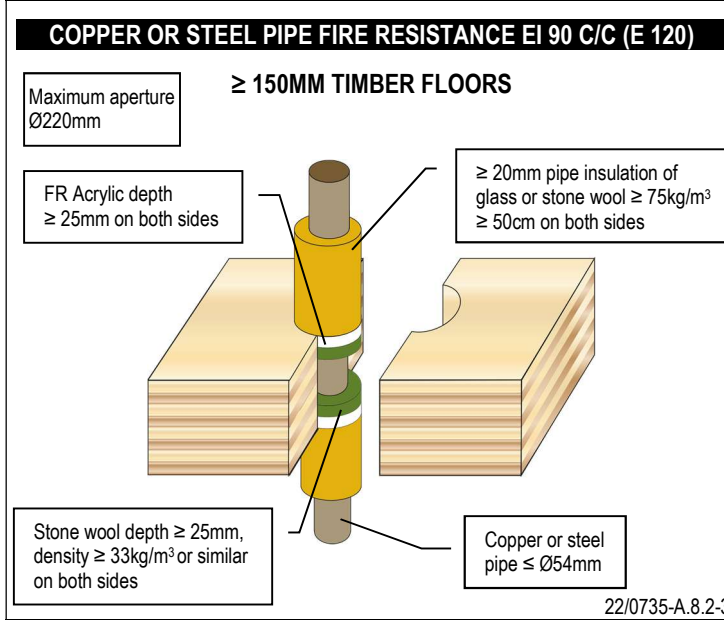
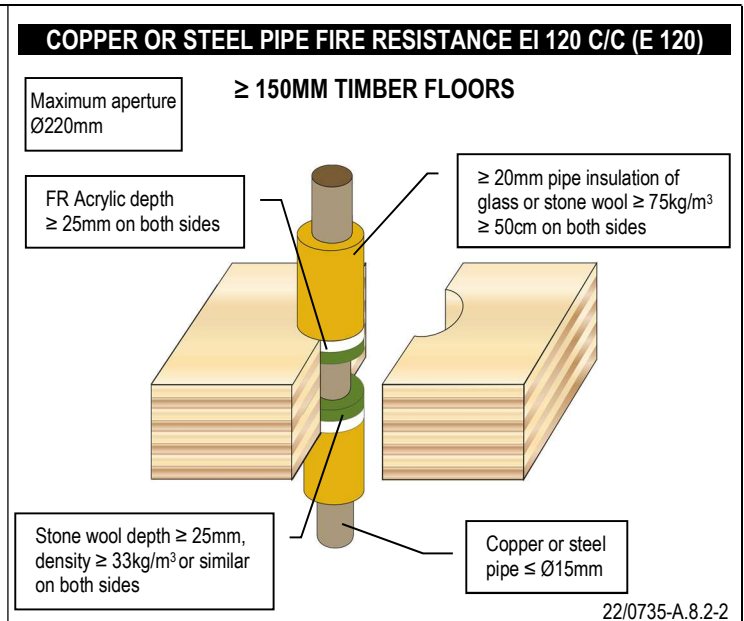
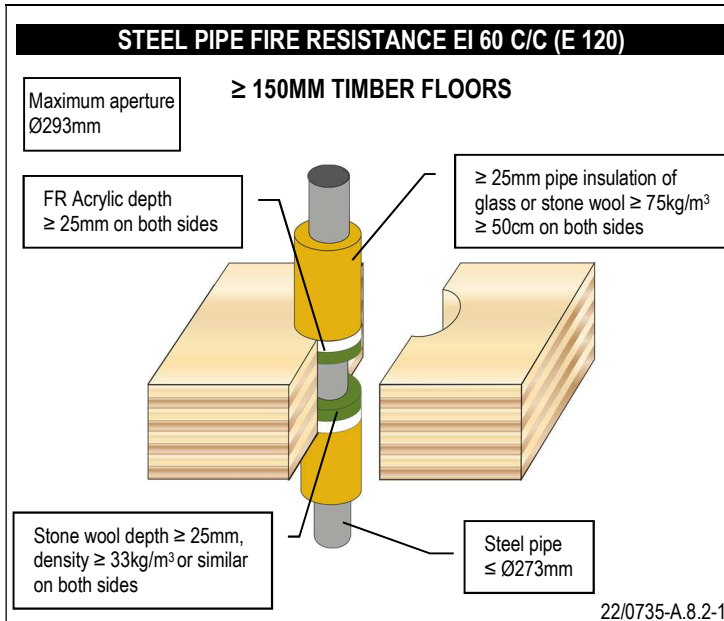

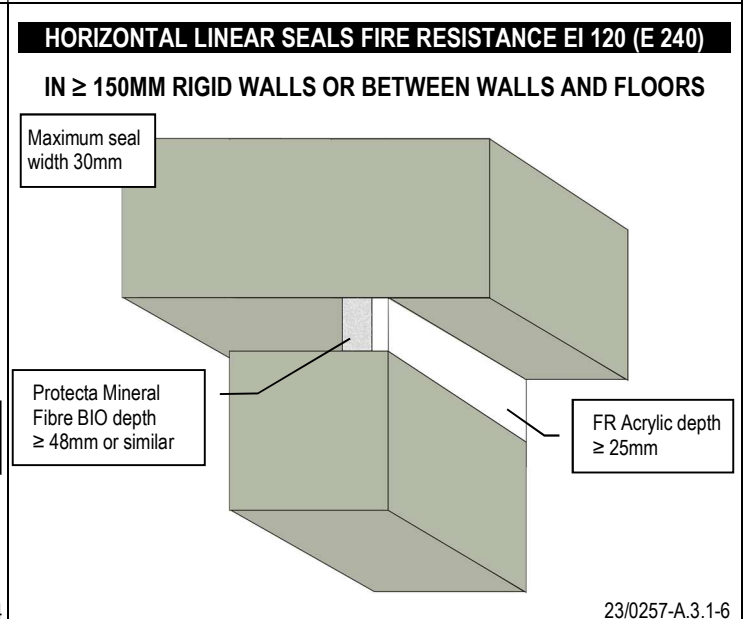
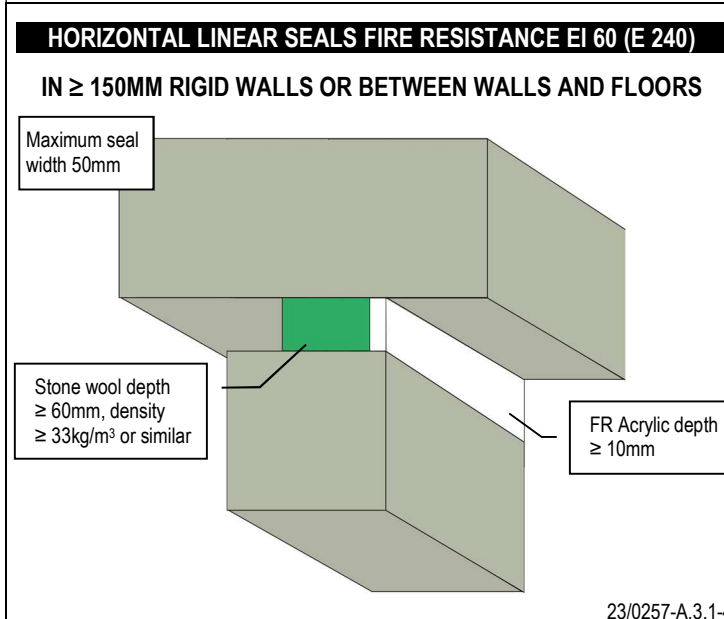
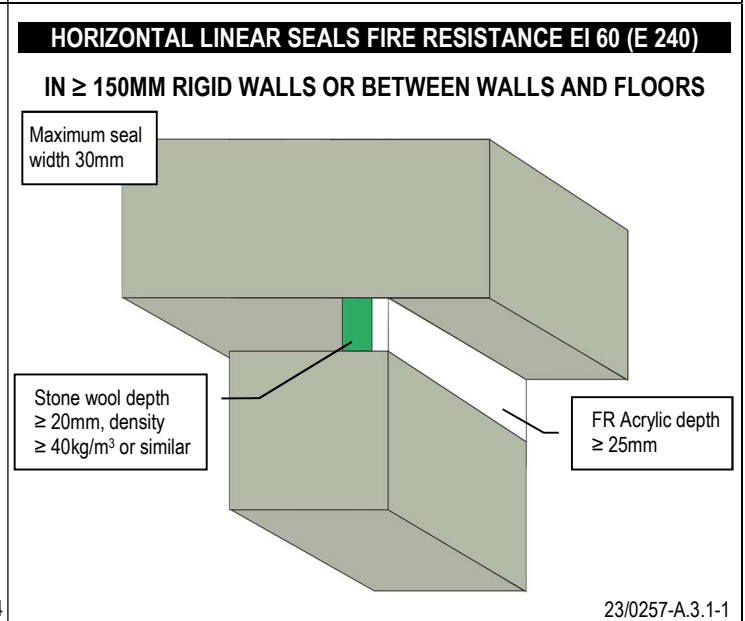
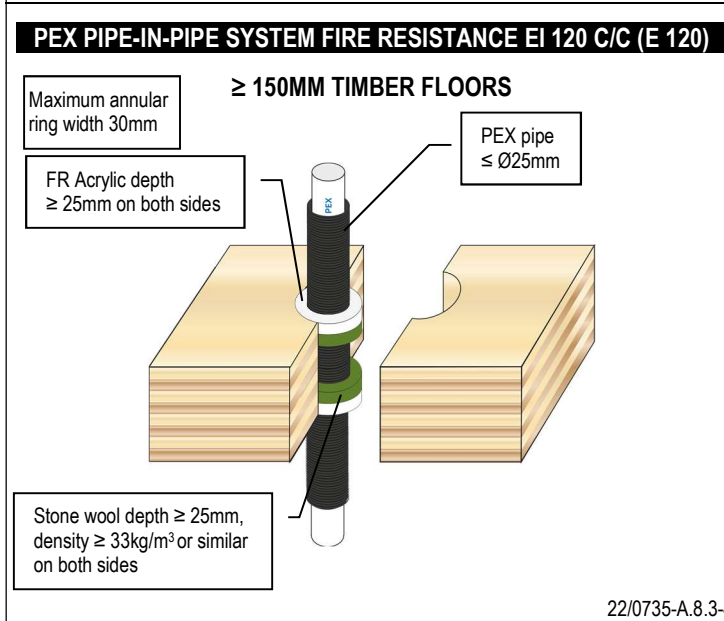
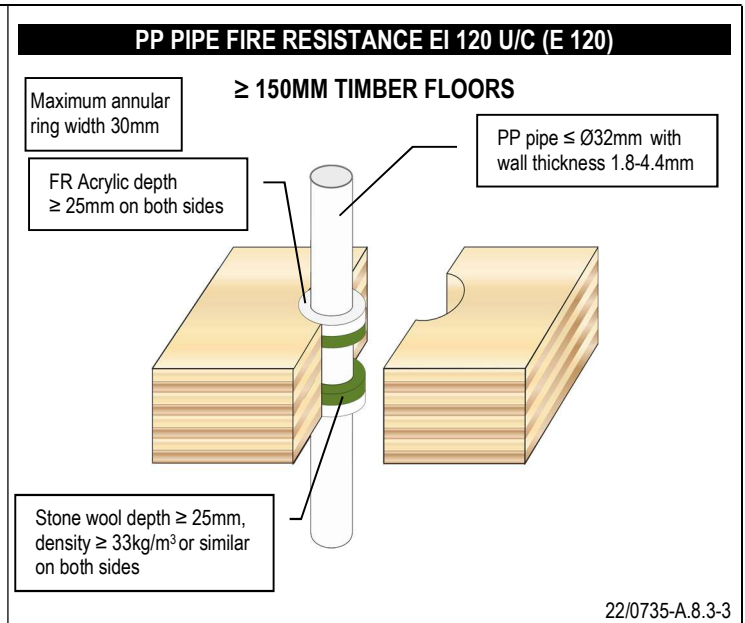
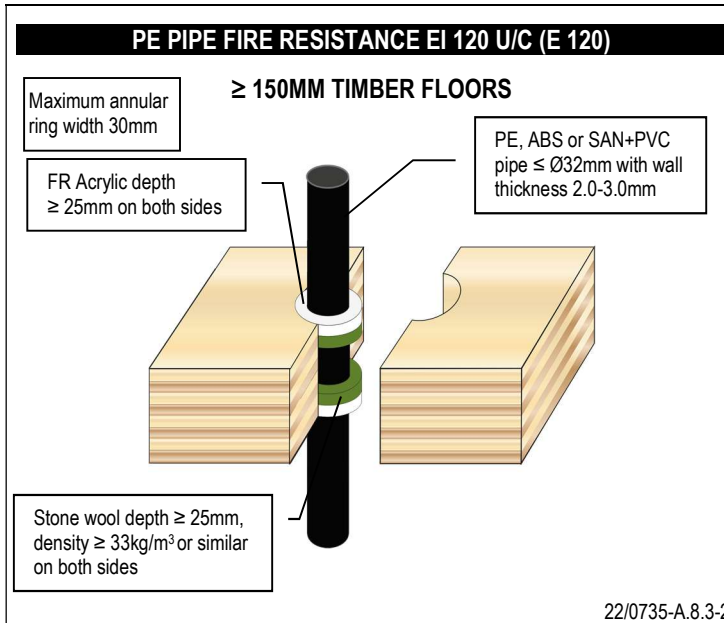

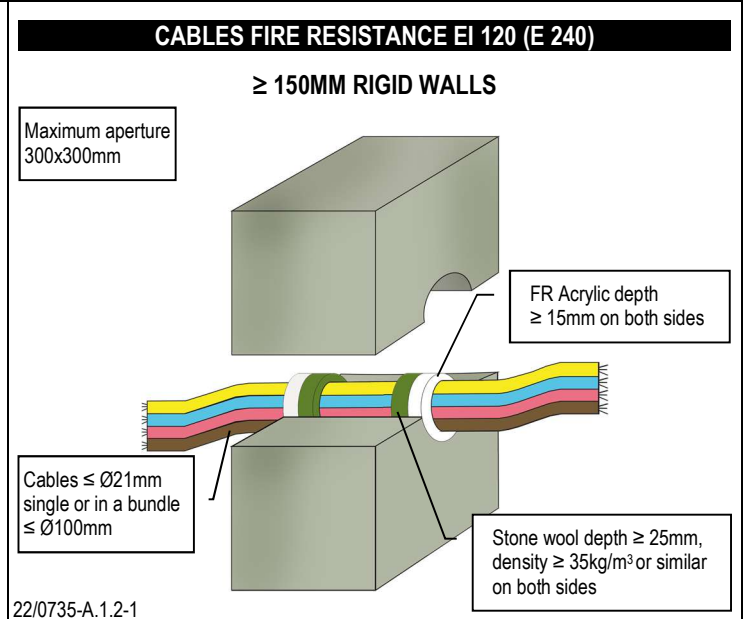
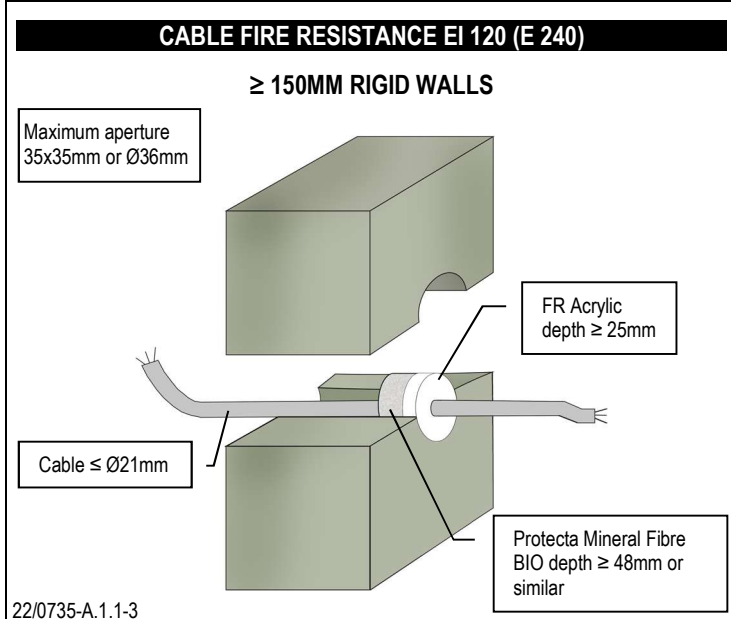
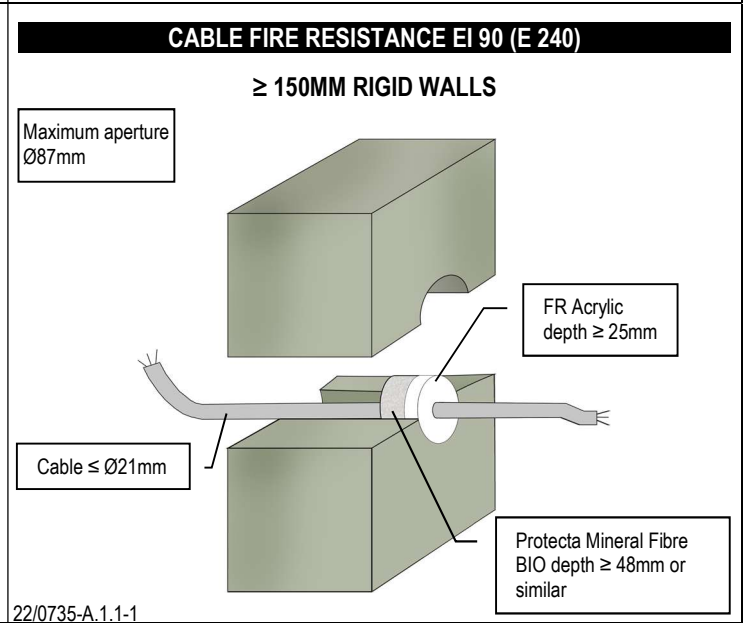
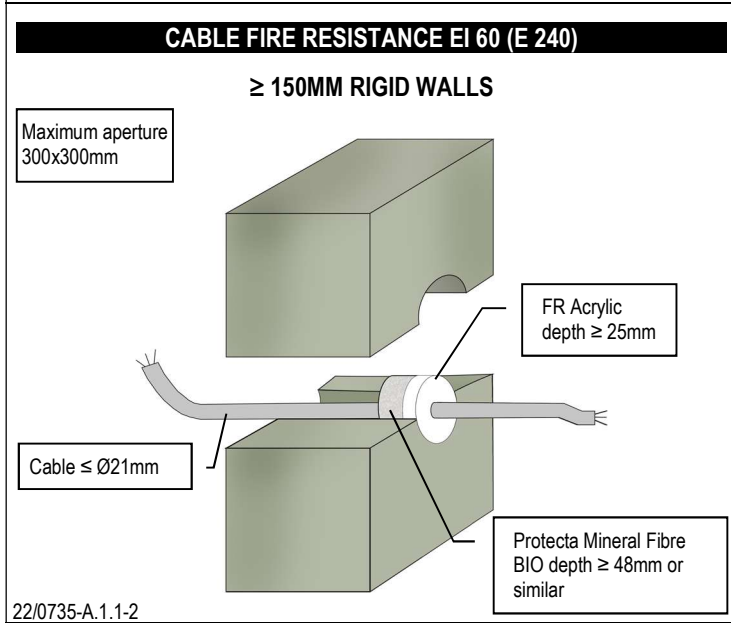
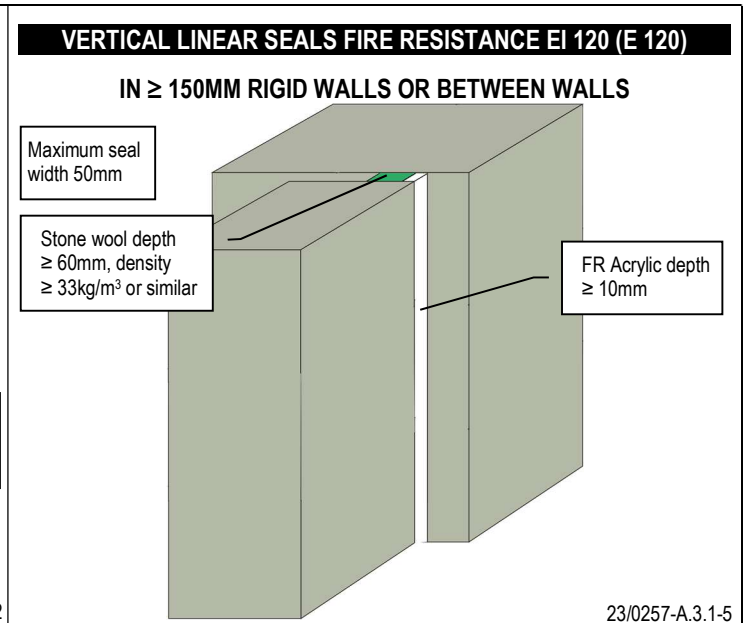
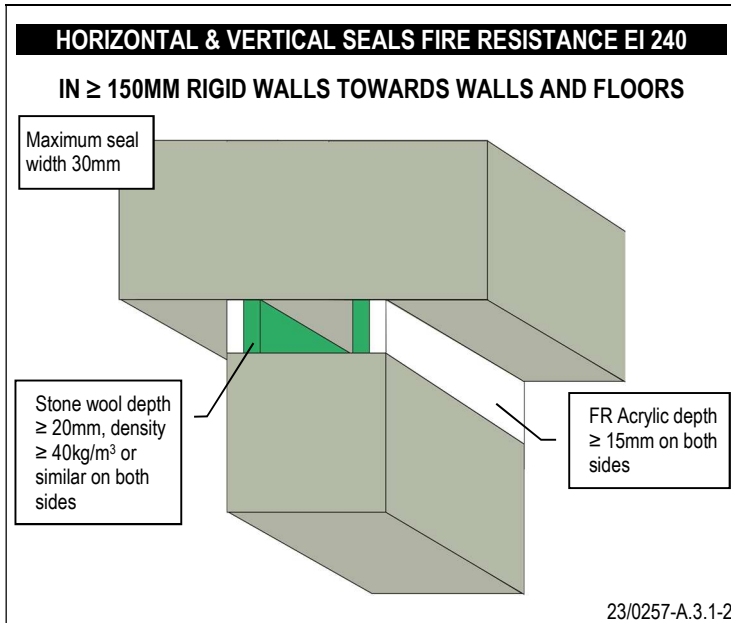

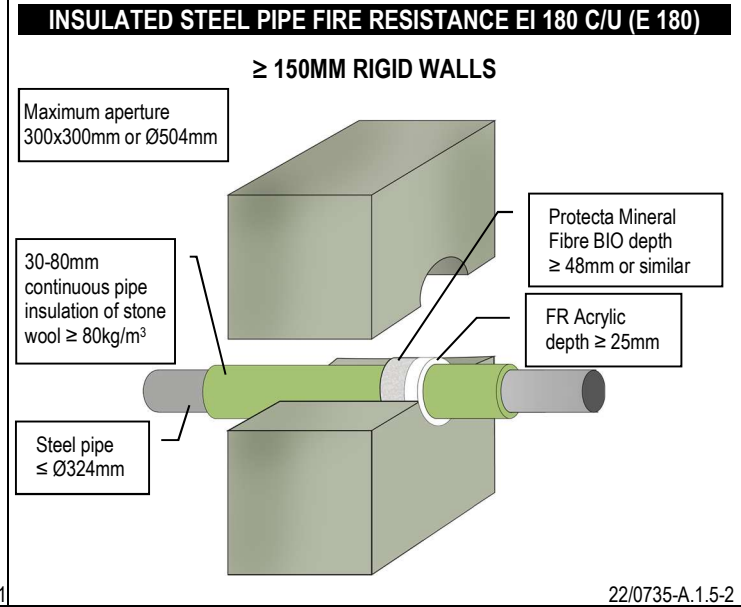
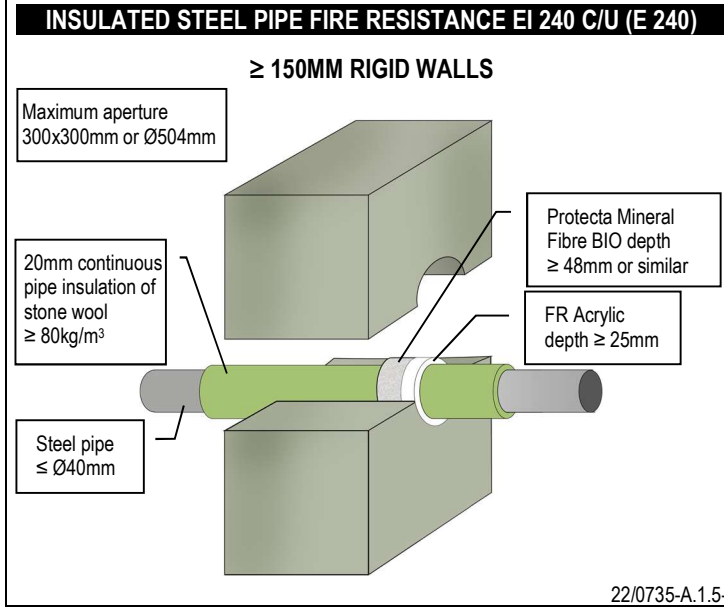
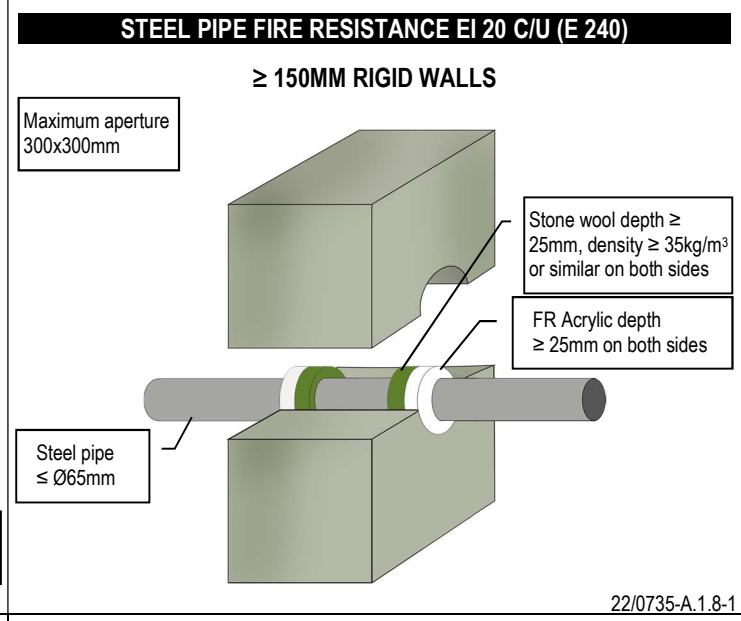
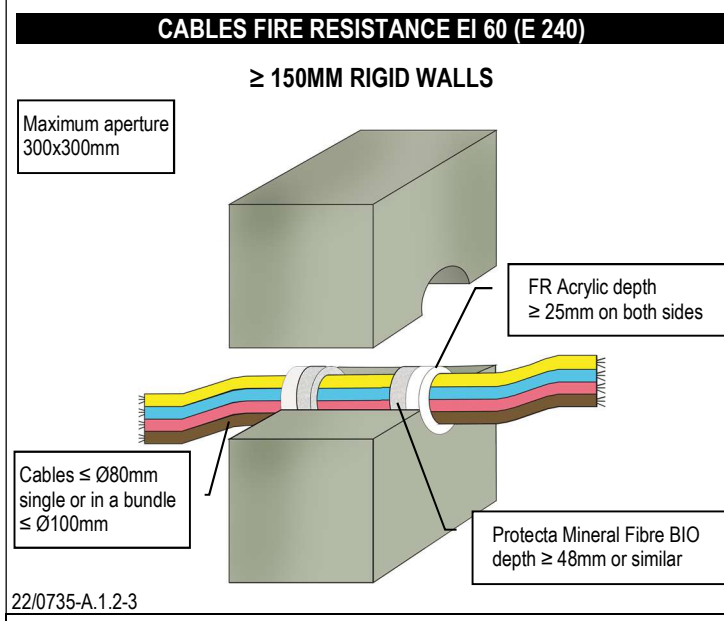
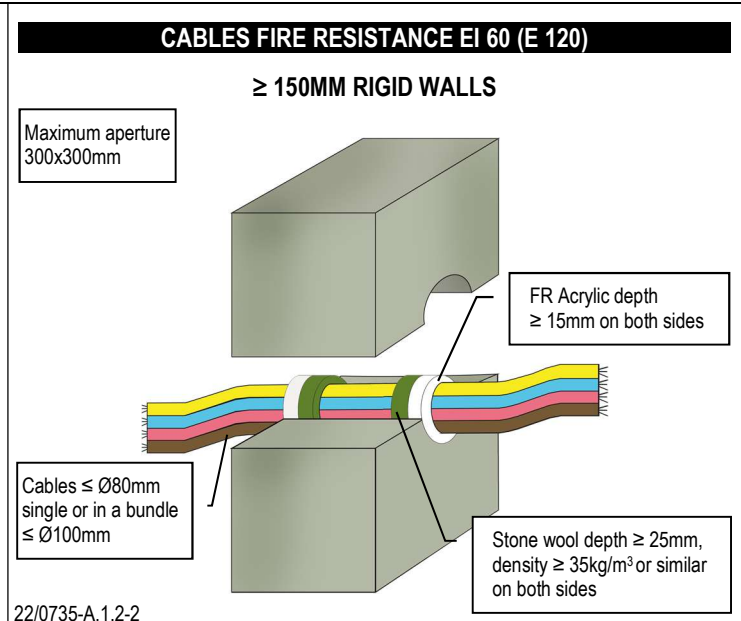
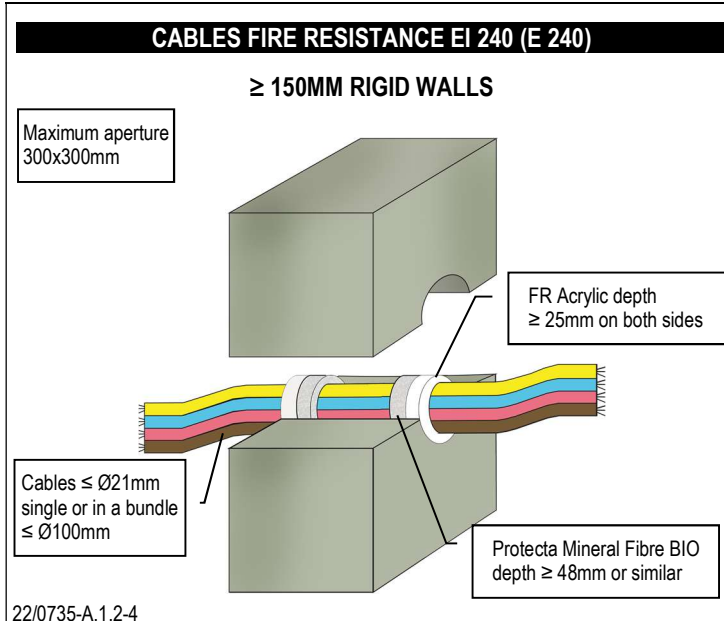

|   |   |
|---|---|
| <p><b>INSULATED STEEL PIPE FIRE RESISTANCE EI 240 C/U (E 240)</b></p> <p><b>≥ 150MM RIGID WALLS</b></p> <p>Maximum aperture 300x300mm or Ø504mm</p> <p>30-80mm continuous pipe insulation of stone wool ≥ 80kg/m<sup>3</sup></p> <p>Stone wool depth ≥ 25mm, density ≥ 35kg/m<sup>3</sup> or similar on both sides</p> <p>FR Acrylic depth ≥ 15mm on both sides</p> <p>Steel pipe ≤ Ø324mm</p> <p>22/0735-A.1.7-2</p> | <p><b>STEEL PIPE FIRE RESISTANCE EI 60 C/U (E 240)</b></p> <p><b>≥ 150MM RIGID WALLS</b></p> <p>Maximum aperture 300x300mm</p> <p>≥ 20mm pipe insulation of stone wool ≥ 80kg/m<sup>3</sup> ≥ 100cm on both sides</p> <p>FR Acrylic depth ≥ 25mm</p> <p>Steel pipe ≤ Ø40mm</p> <p>Stone wool depth ≥ 25mm, density ≥ 40kg/m<sup>3</sup> or similar</p> <p>22/0735-A.1.4-3</p>                               |
| <p><b>STEEL PIPE FIRE RESISTANCE EI 240 C/U (E 240)</b></p> <p><b>≥ 150MM RIGID WALLS</b></p> <p>Maximum annular ring width 18mm</p> <p>≥ 20mm pipe insulation of stone wool ≥ 80kg/m<sup>3</sup> ≥ 100cm on both sides</p> <p>FR Acrylic depth ≥ 15mm</p> <p>Steel pipe ≤ Ø40mm</p> <p>Stone wool depth ≥ 20mm, density ≥ 40kg/m<sup>3</sup> or similar</p> <p>22/0735-A.1.3-4</p>                                   | <p><b>STEEL PIPE FIRE RESISTANCE EI 60 C/U (E 240)</b></p> <p><b>≥ 150MM RIGID WALLS</b></p> <p>Maximum aperture 300x300mm</p> <p>≥ 30mm pipe insulation of stone wool ≥ 80kg/m<sup>3</sup> ≥ 100cm on both sides</p> <p>FR Acrylic depth ≥ 25mm</p> <p>Steel pipe ≤ Ø219mm</p> <p>Stone wool depth ≥ 25mm, density ≥ 40kg/m<sup>3</sup> or similar</p> <p>22/0735-A.1.4-4</p>                              |
| <p><b>STEEL PIPE FIRE RESISTANCE EI 90 C/U (E 180)</b></p> <p><b>≥ 150MM RIGID WALLS</b></p> <p>Maximum annular ring width 18mm</p> <p>≥ 30mm pipe insulation of stone wool ≥ 80kg/m<sup>3</sup> ≥ 100cm on both sides</p> <p>FR Acrylic depth ≥ 15mm</p> <p>Steel pipe ≤ Ø219mm</p> <p>Stone wool depth ≥ 20mm, density ≥ 40kg/m<sup>3</sup> or similar</p> <p>22/0735-A.1.3-5</p>                                   | <p><b>STEEL PIPE FIRE RESISTANCE EI 120 C/U (E 240)</b></p> <p><b>≥ 150MM RIGID WALLS</b></p> <p>Maximum aperture 300x300mm</p> <p>≥ 30mm pipe insulation of stone wool ≥ 80kg/m<sup>3</sup> ≥ 100cm on both sides</p> <p>FR Acrylic depth ≥ 15mm on both sides</p> <p>Steel pipe ≤ Ø219mm</p> <p>Stone wool depth ≥ 20mm, density ≥ 40kg/m<sup>3</sup> or similar on both sides</p> <p>22/0735-A.1.6-2</p> |

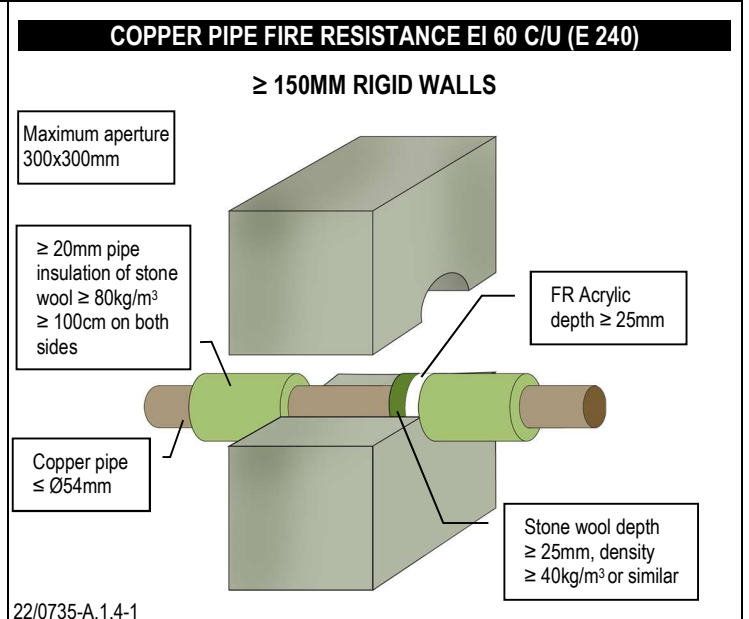
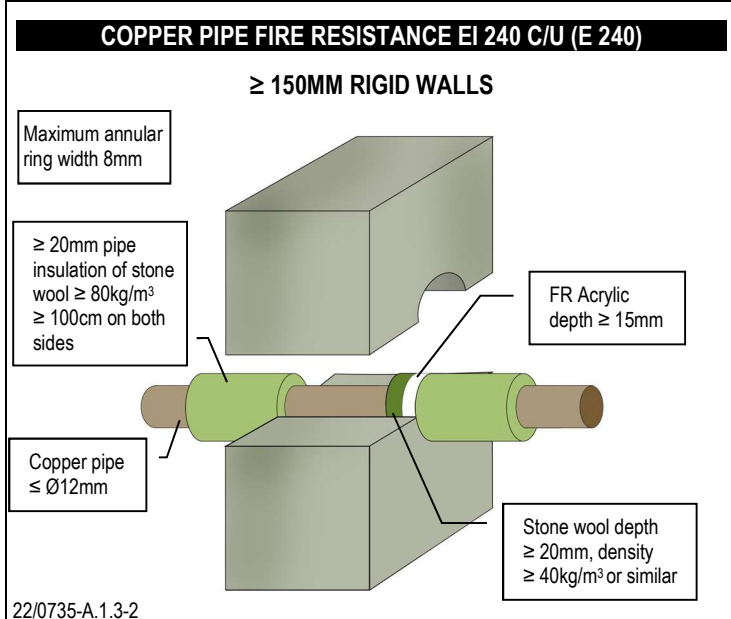
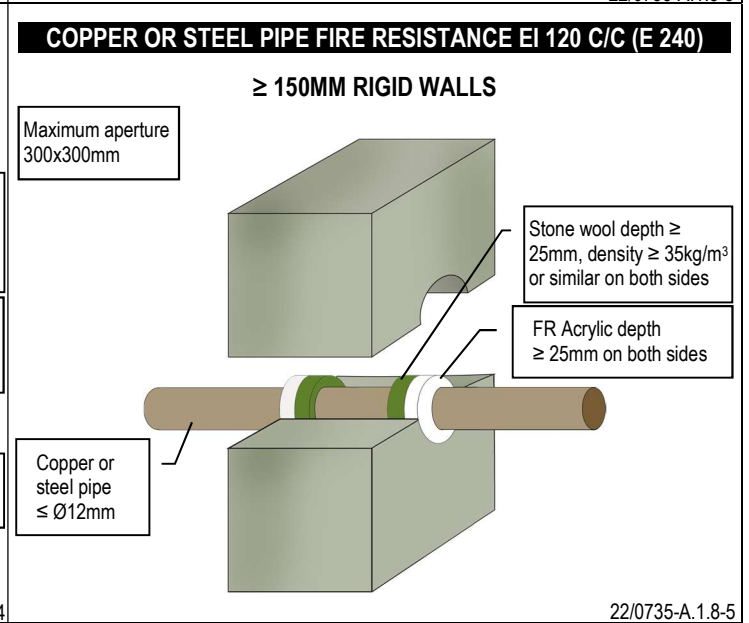
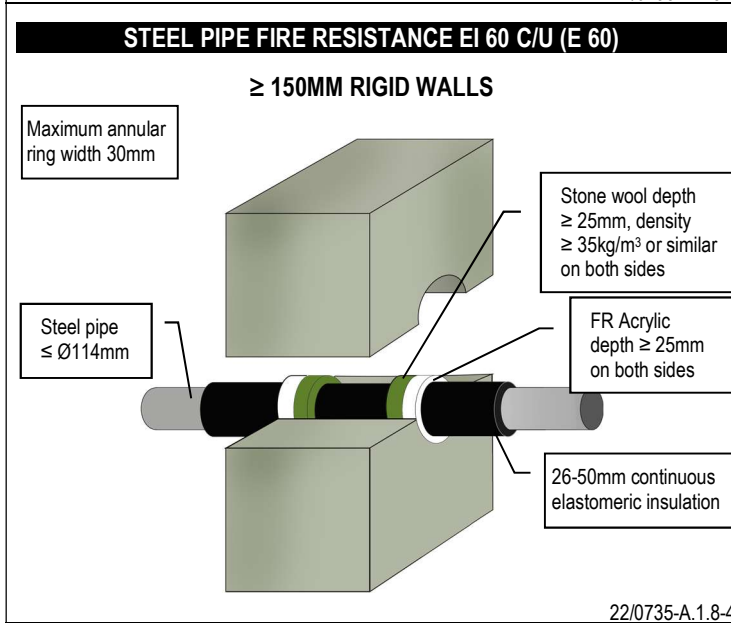
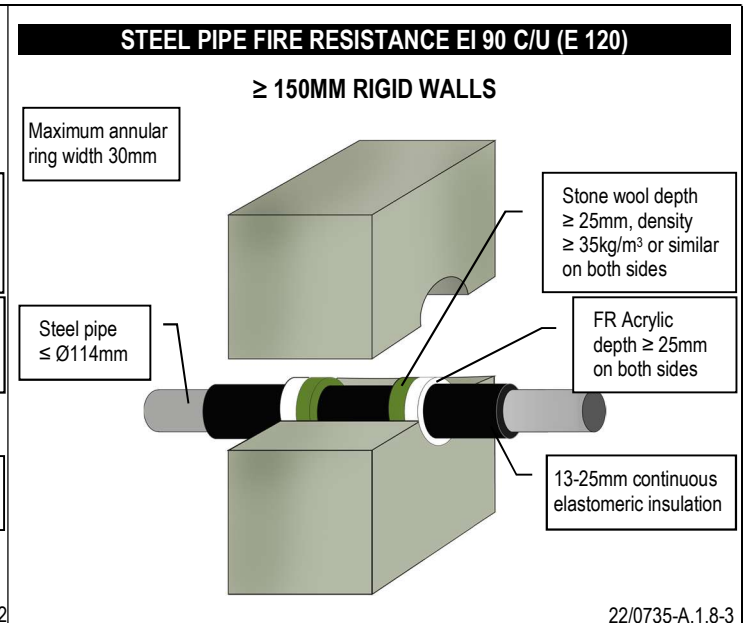
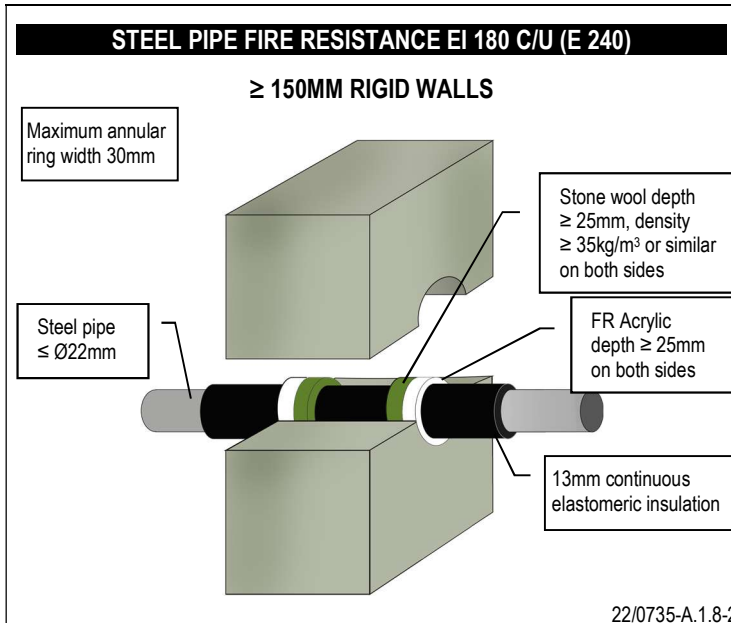

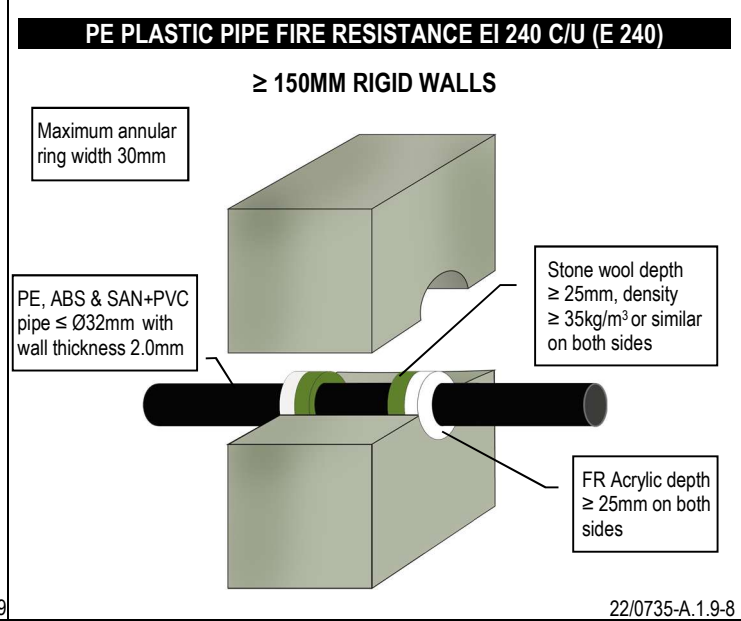
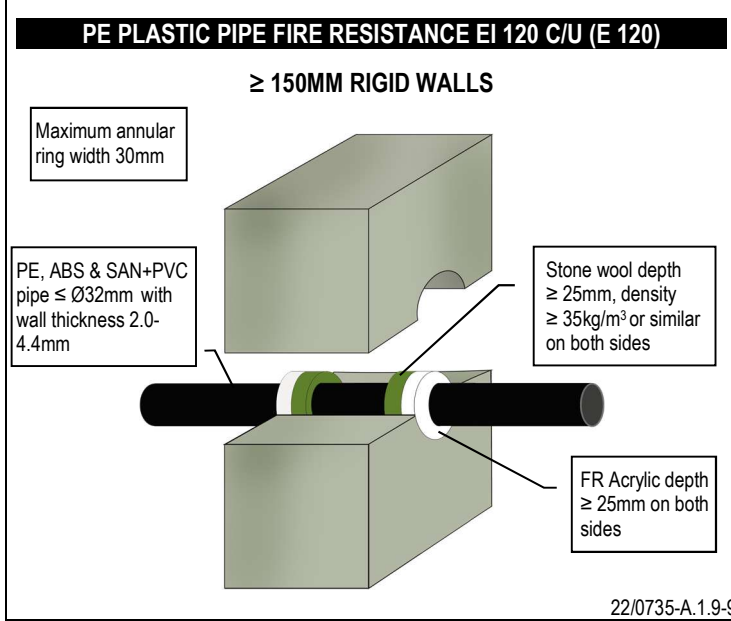
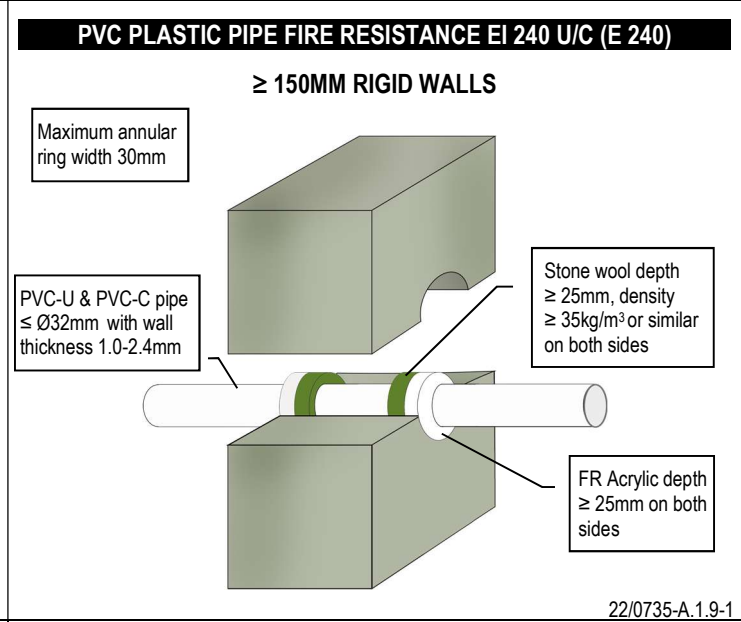
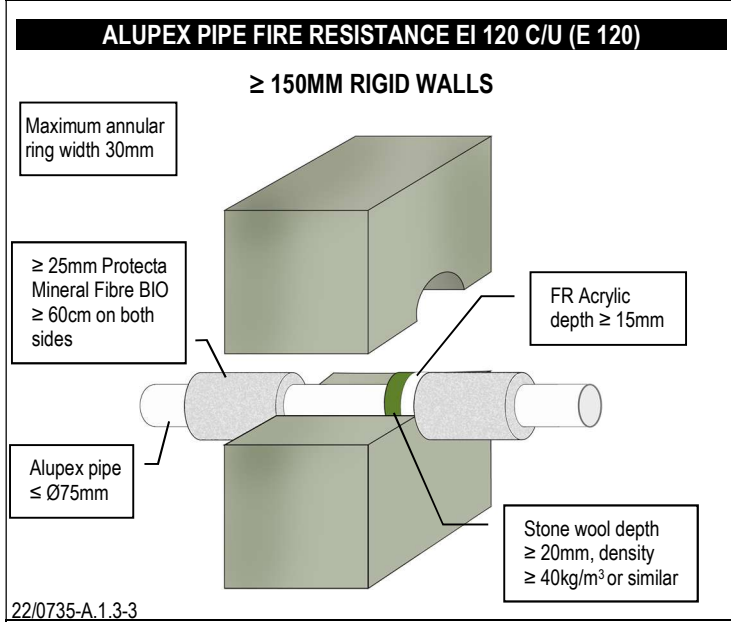
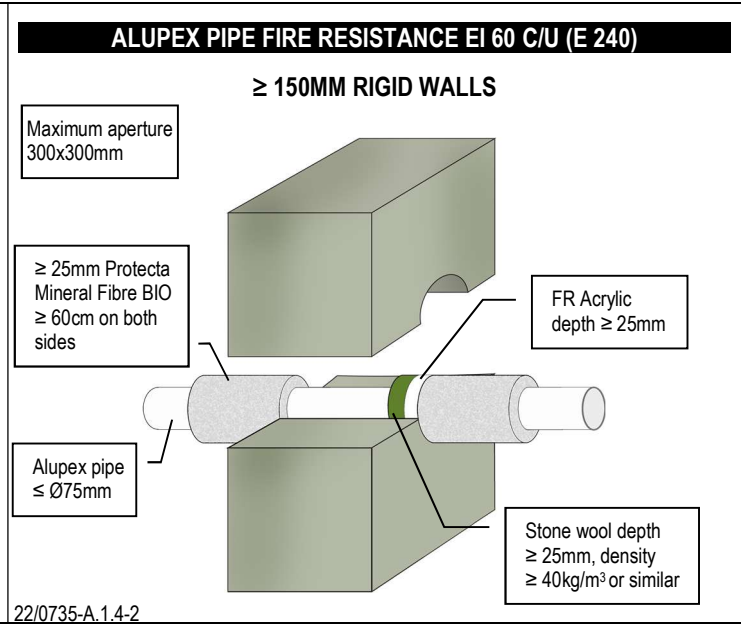
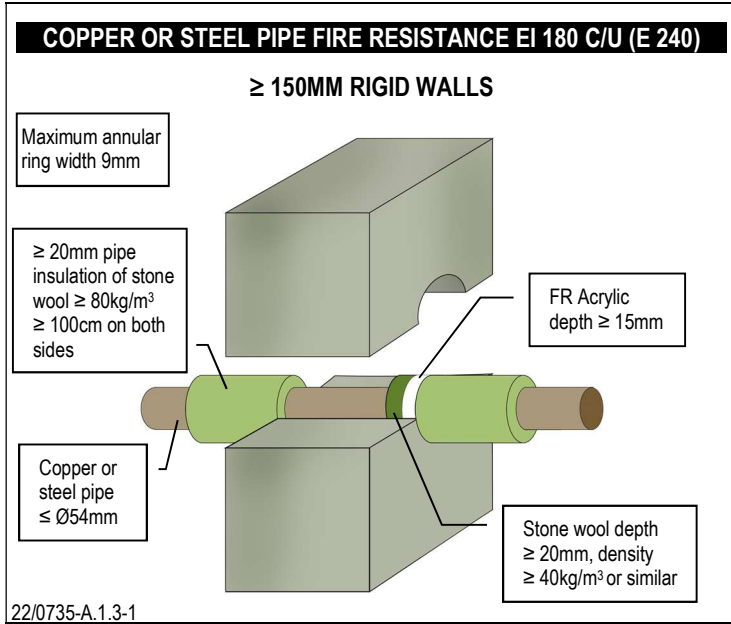

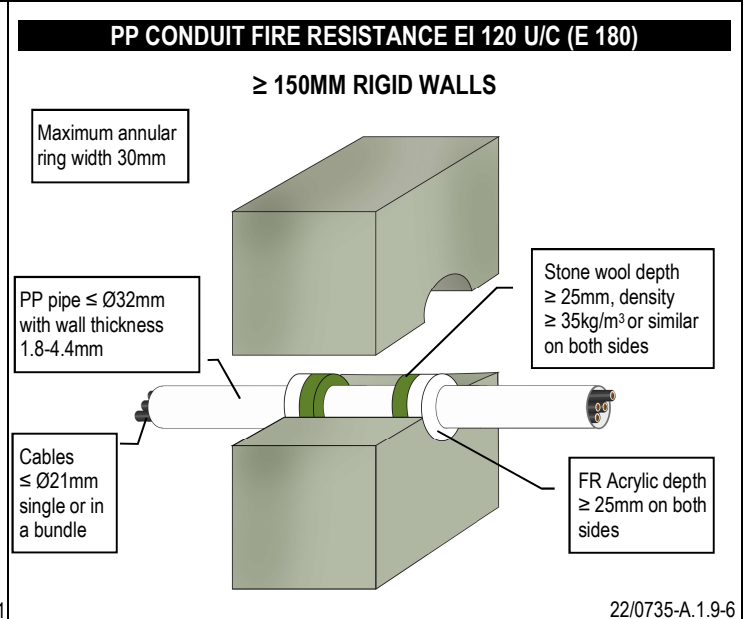
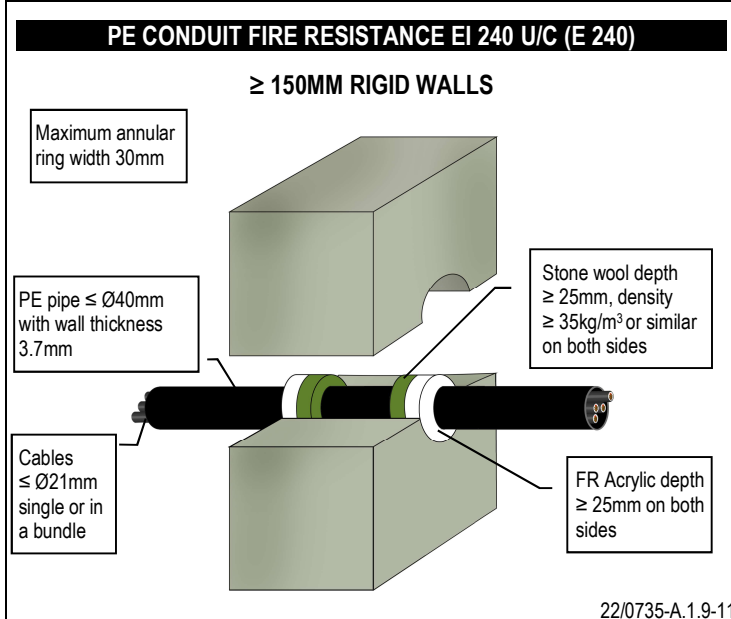
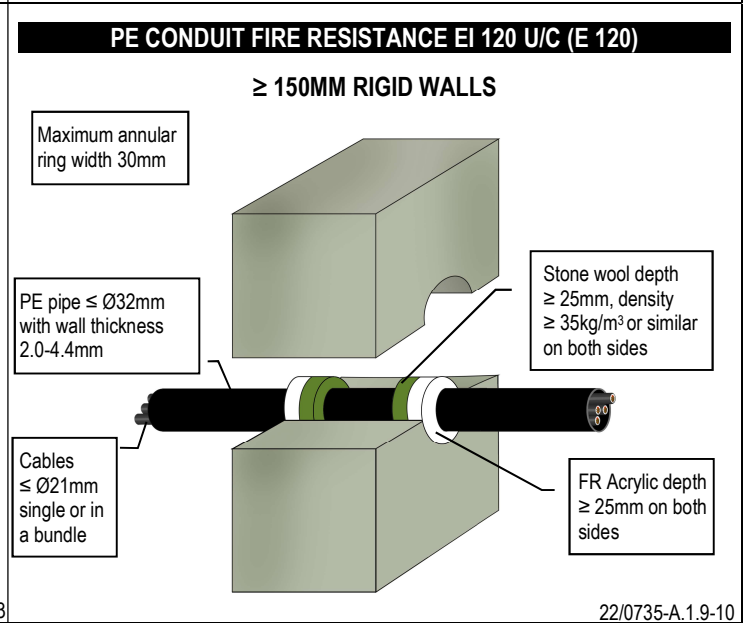
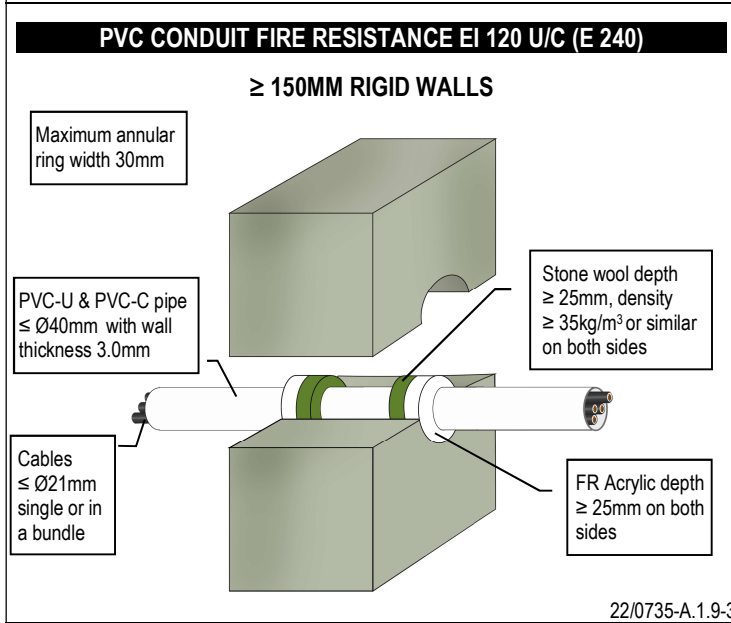
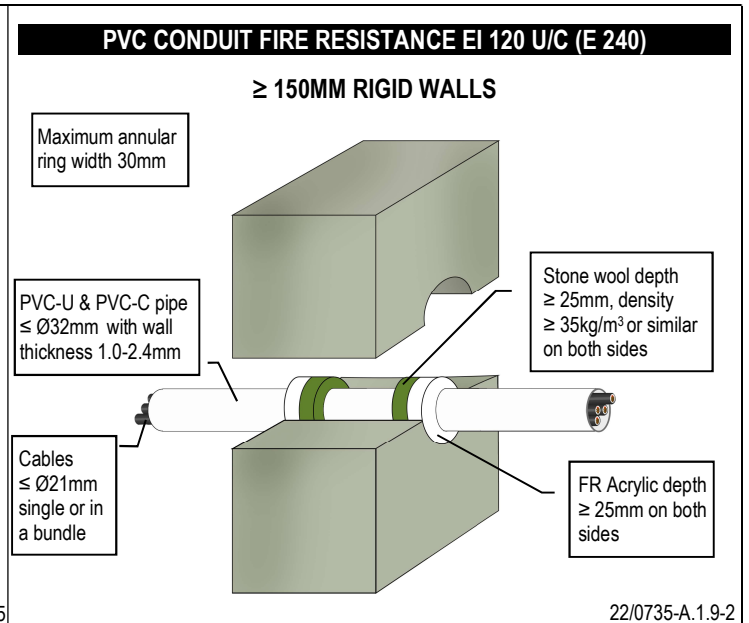
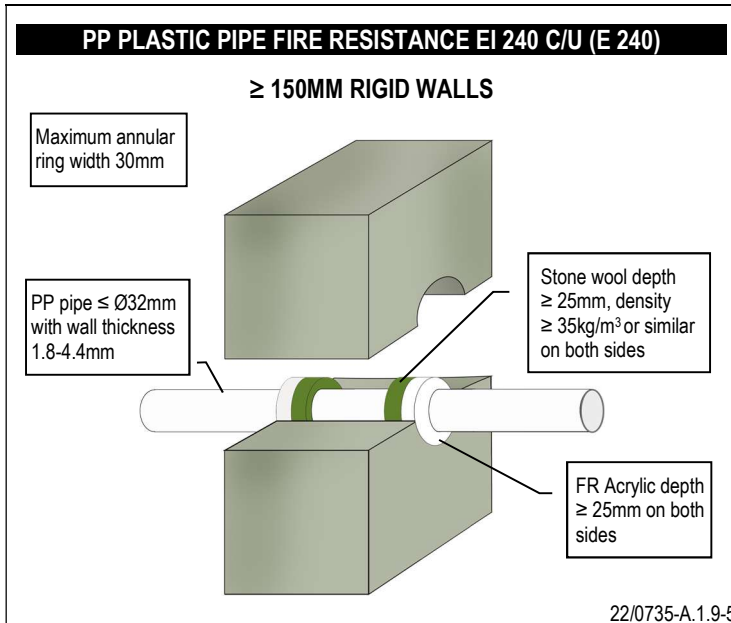

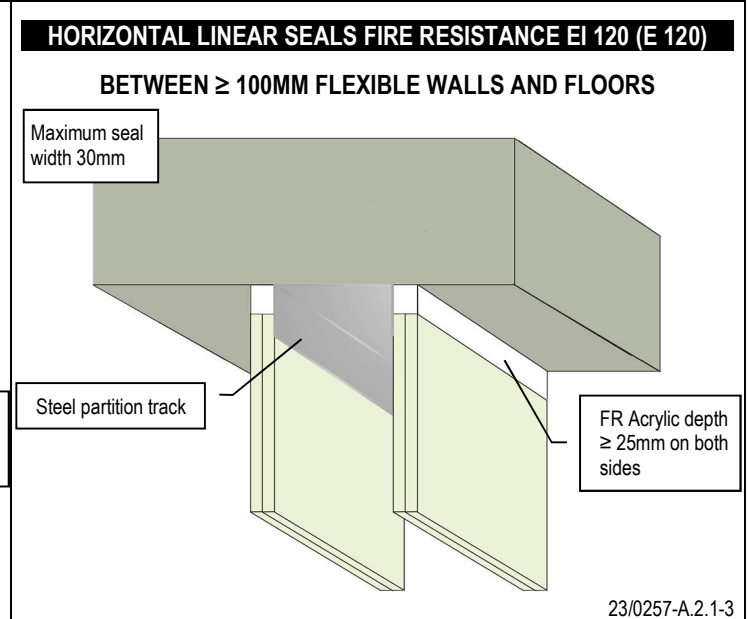
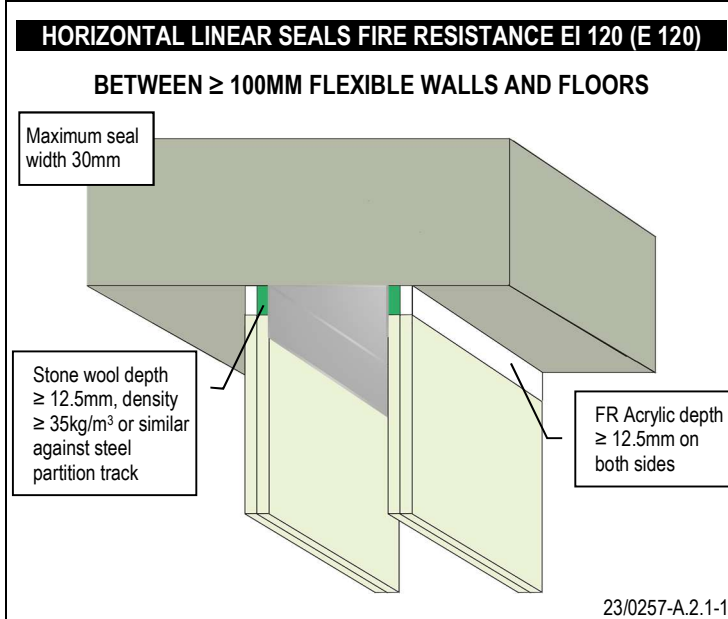
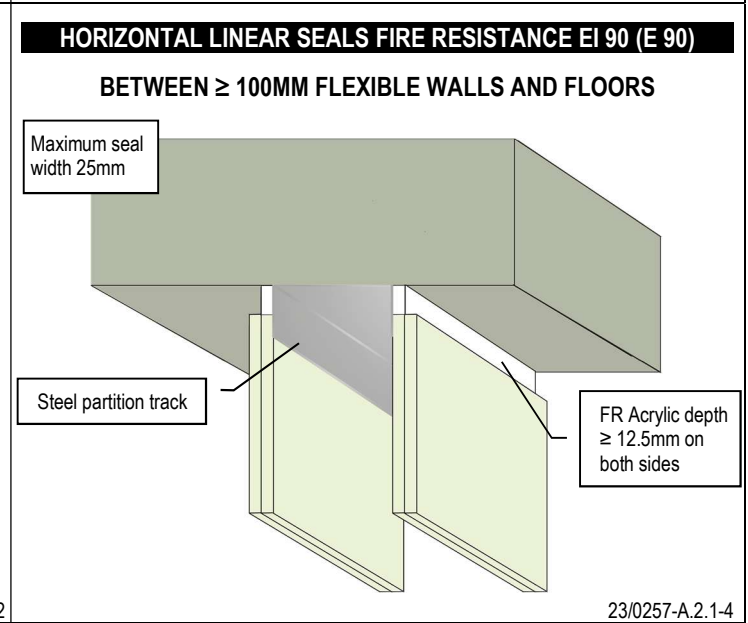
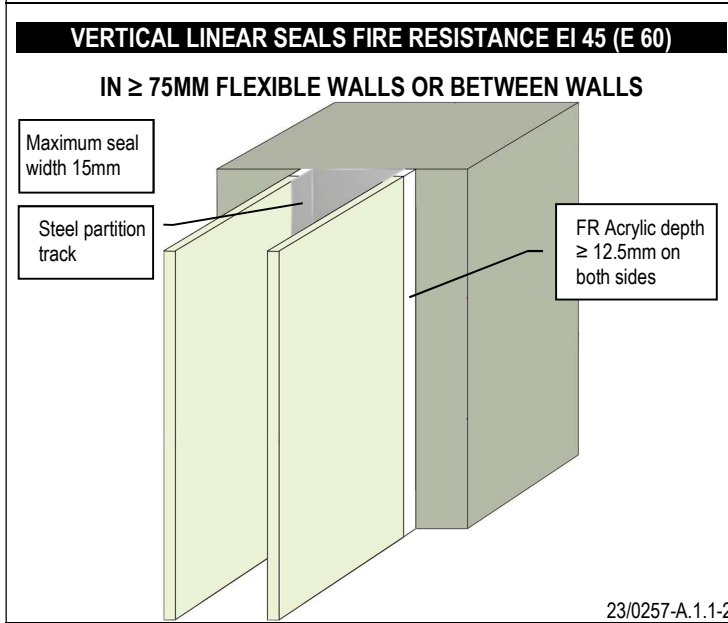
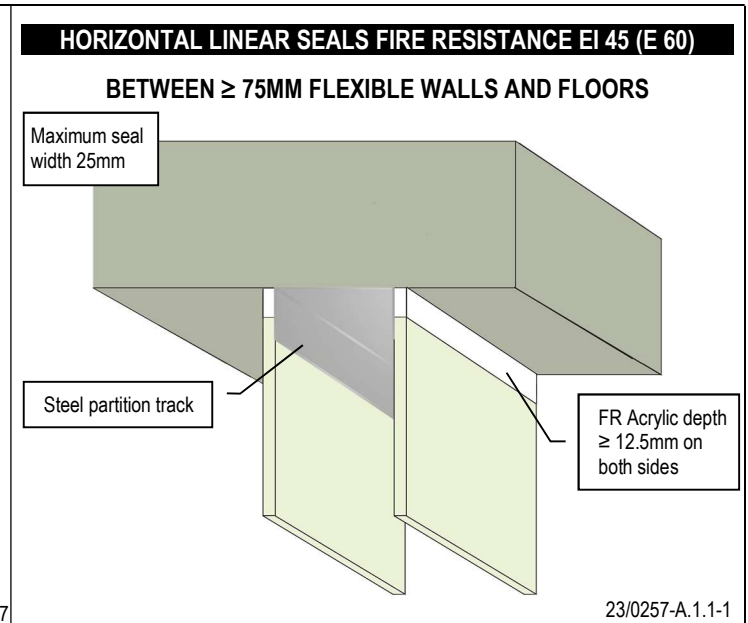
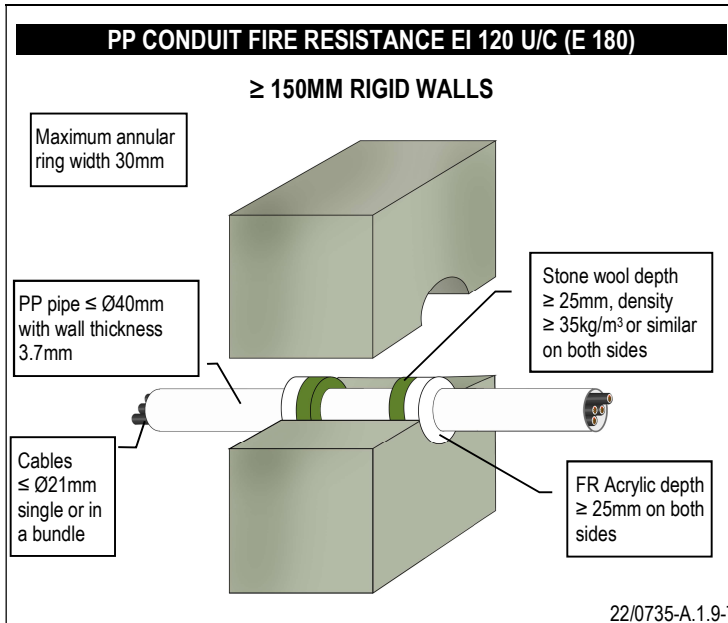

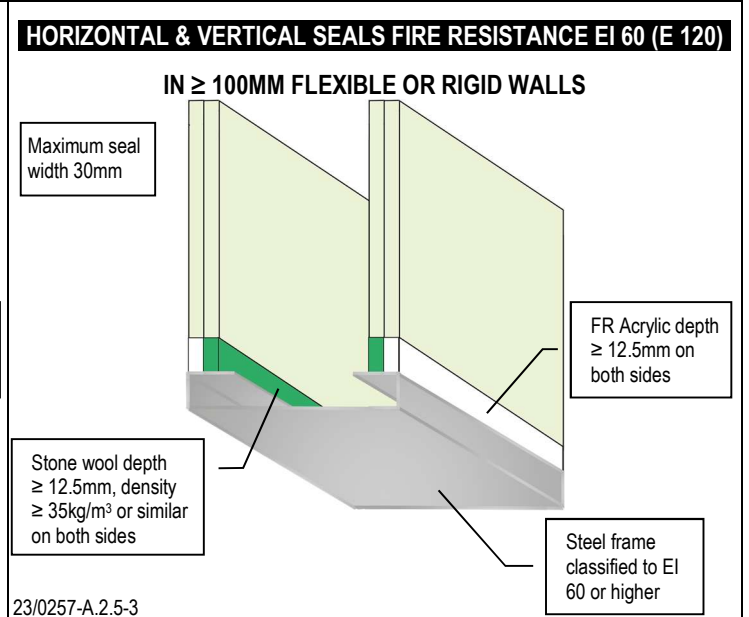
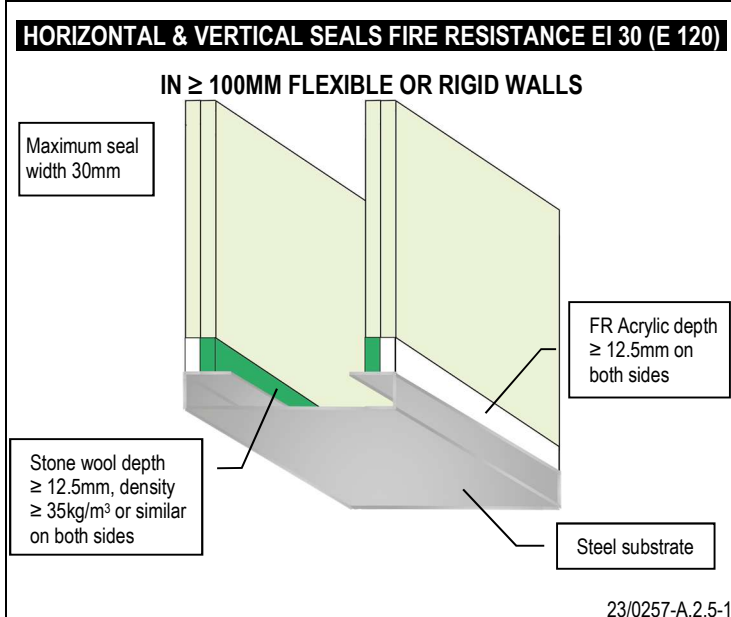
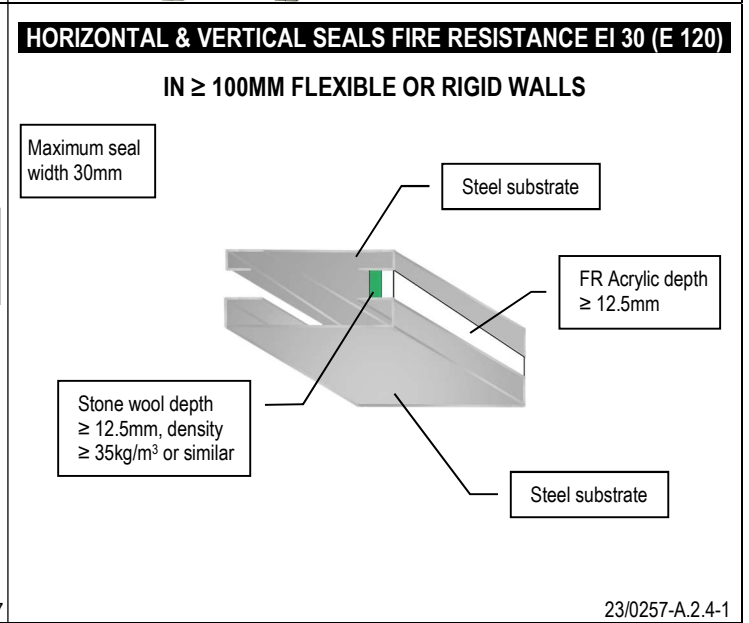
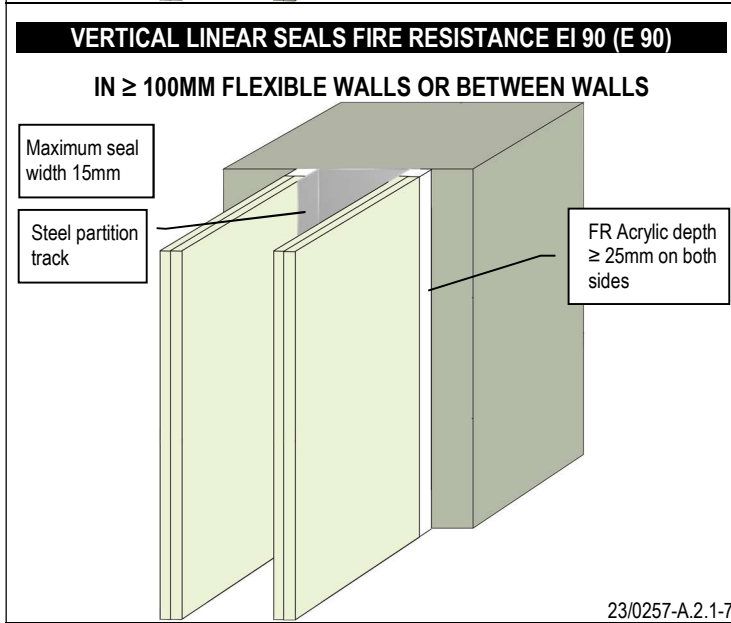
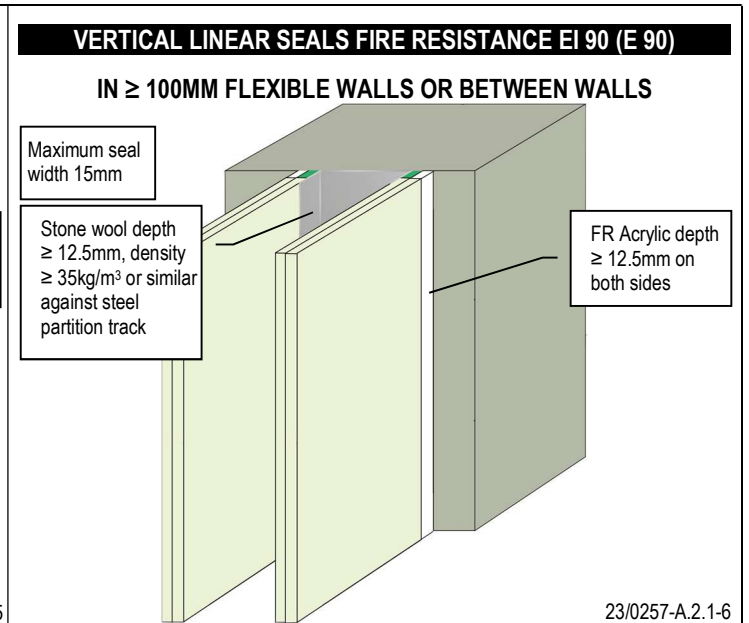
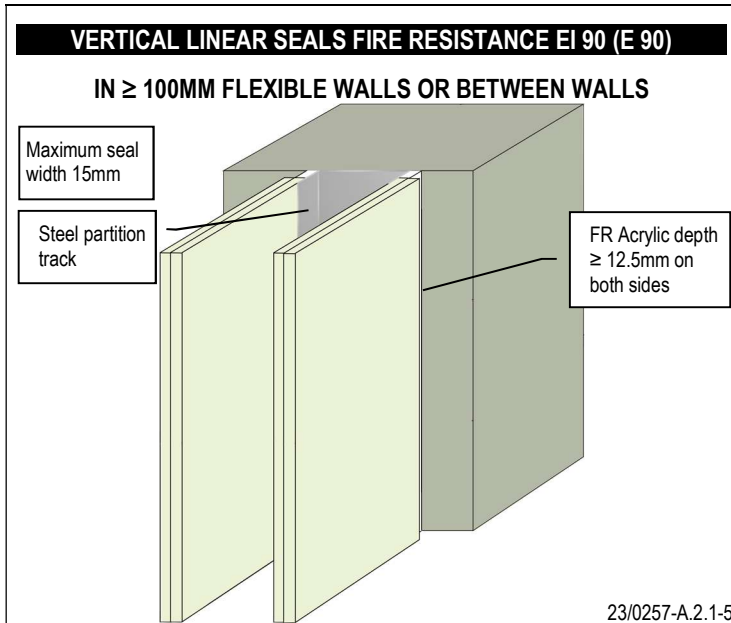

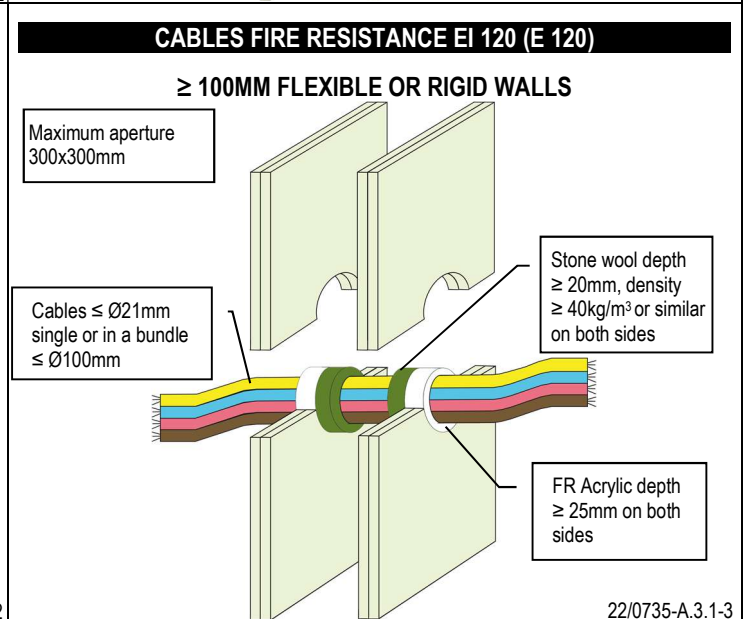
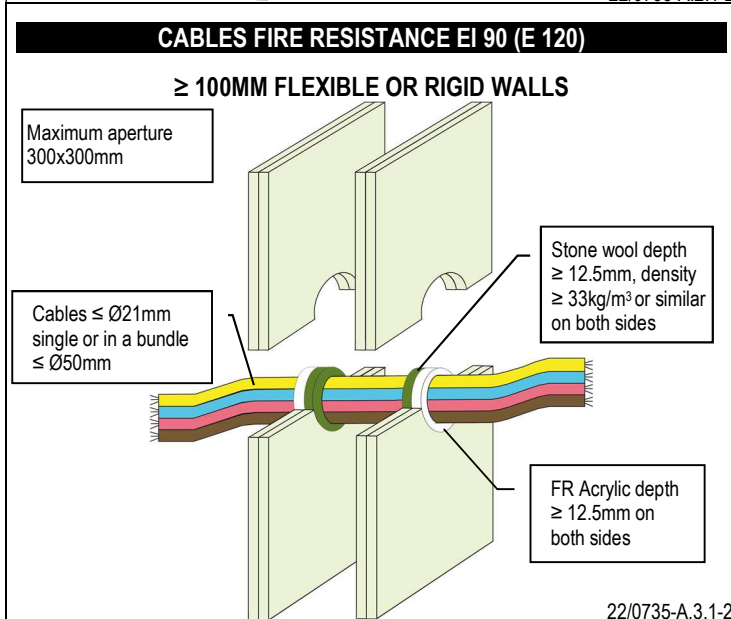
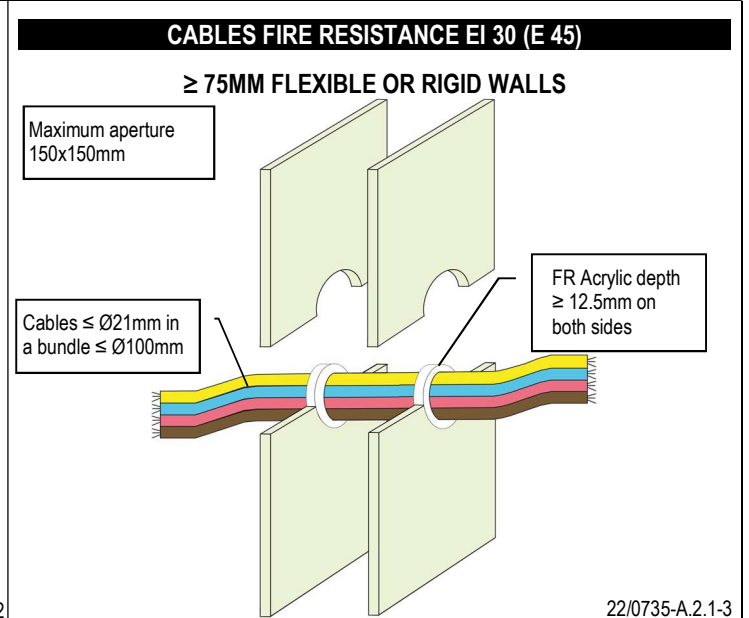
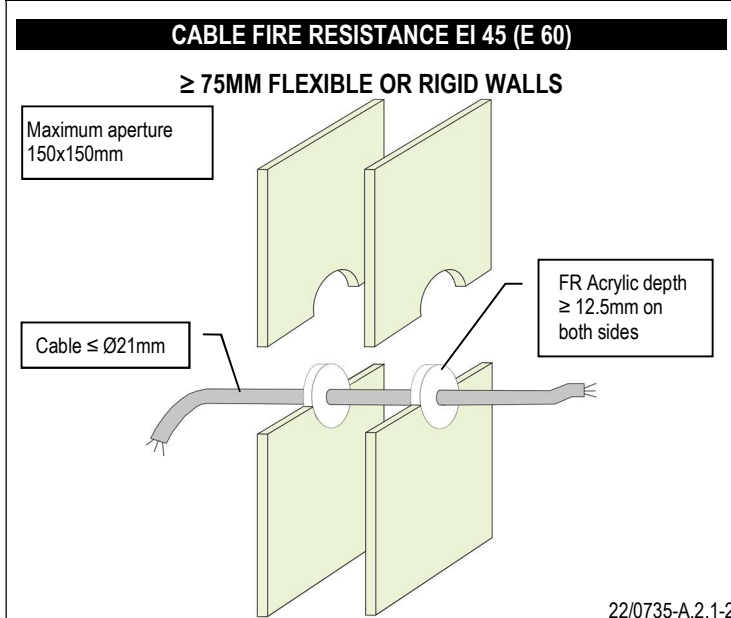
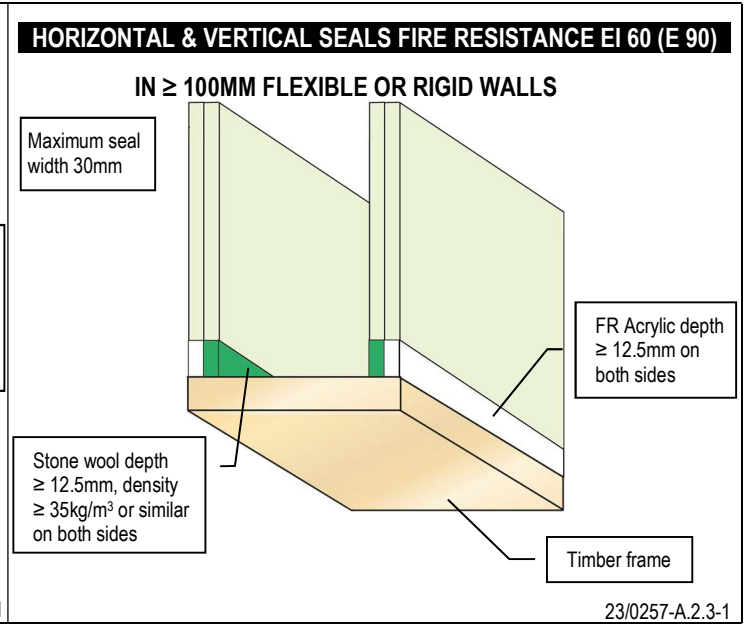
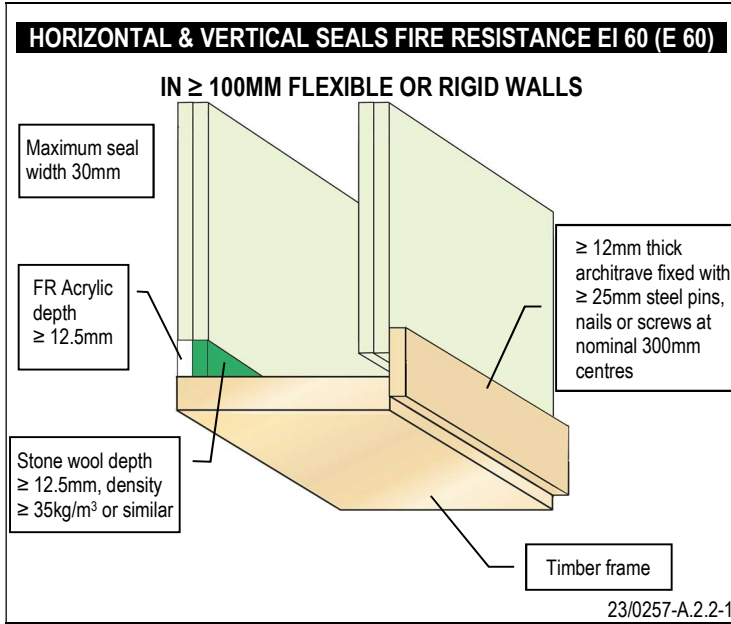

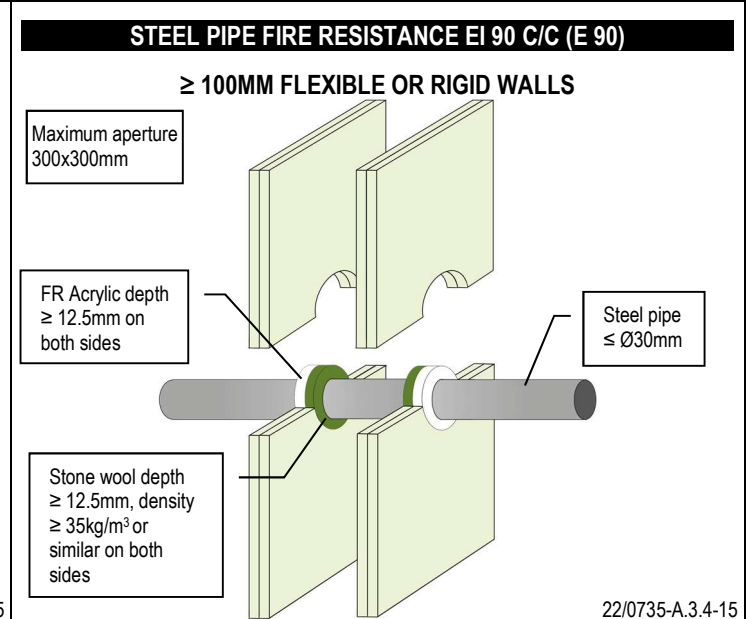
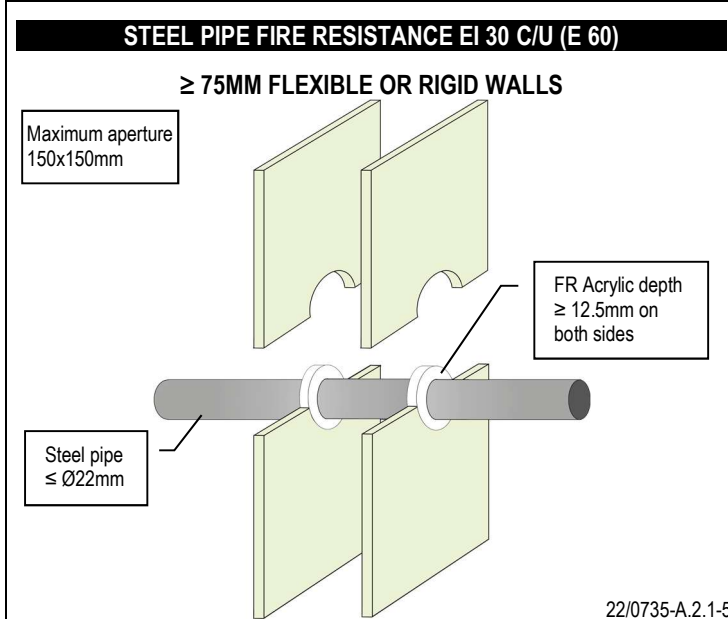
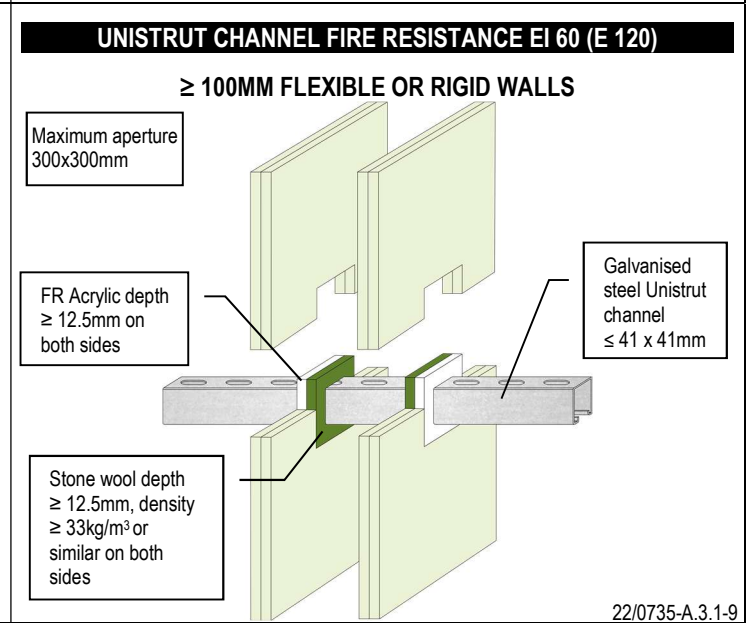
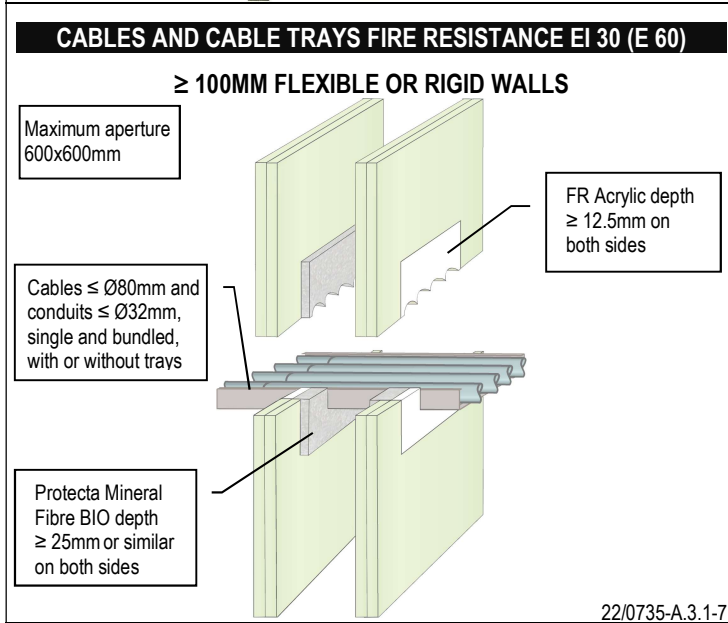
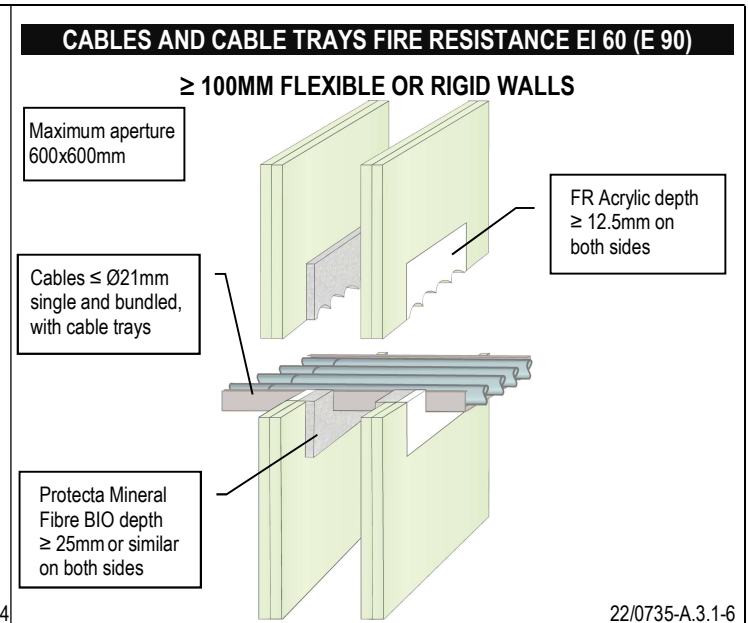
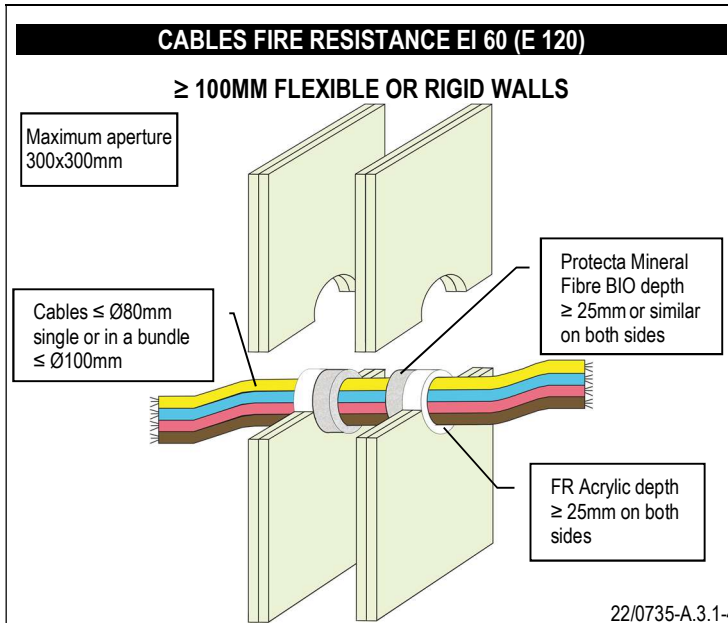

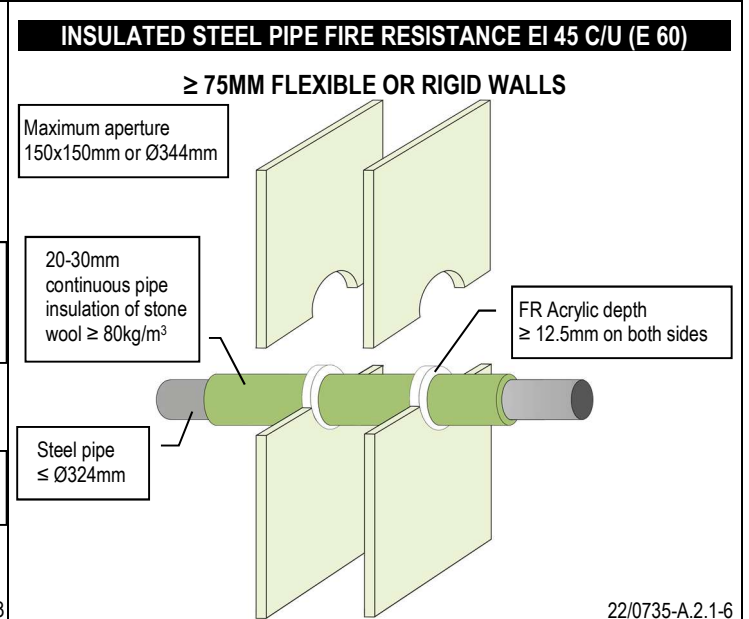
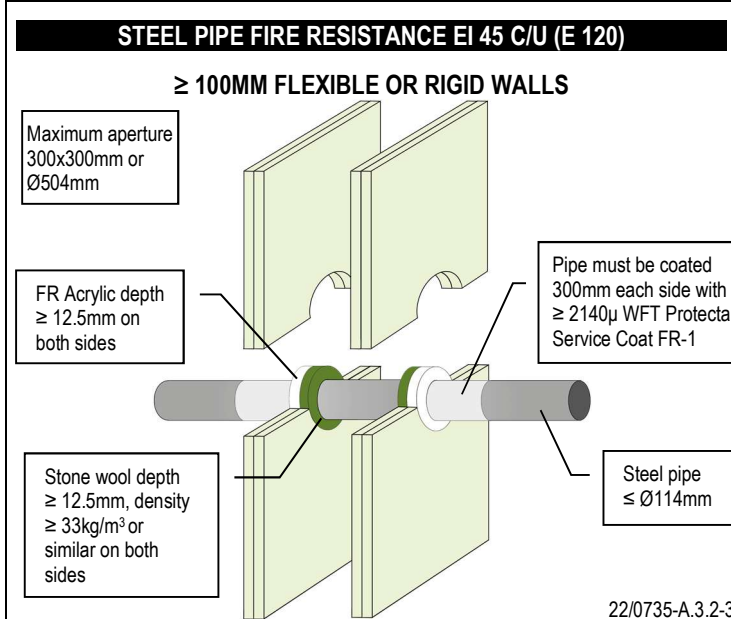
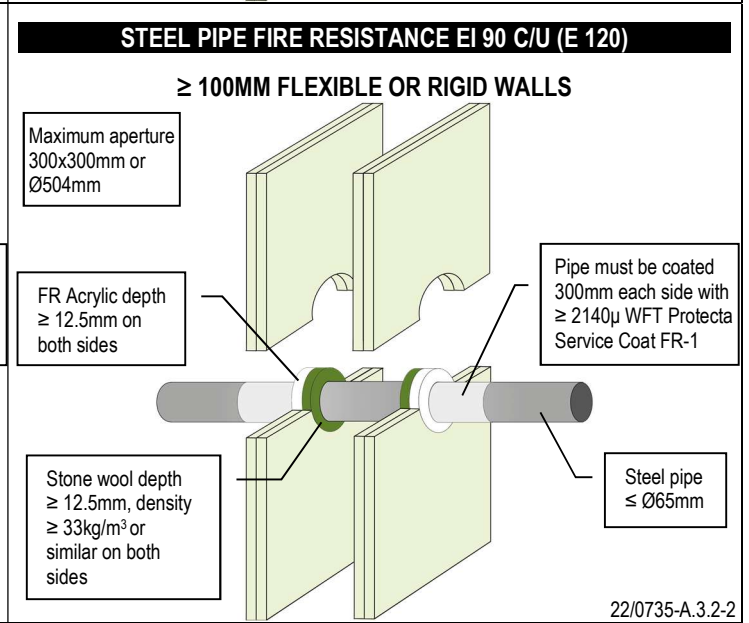
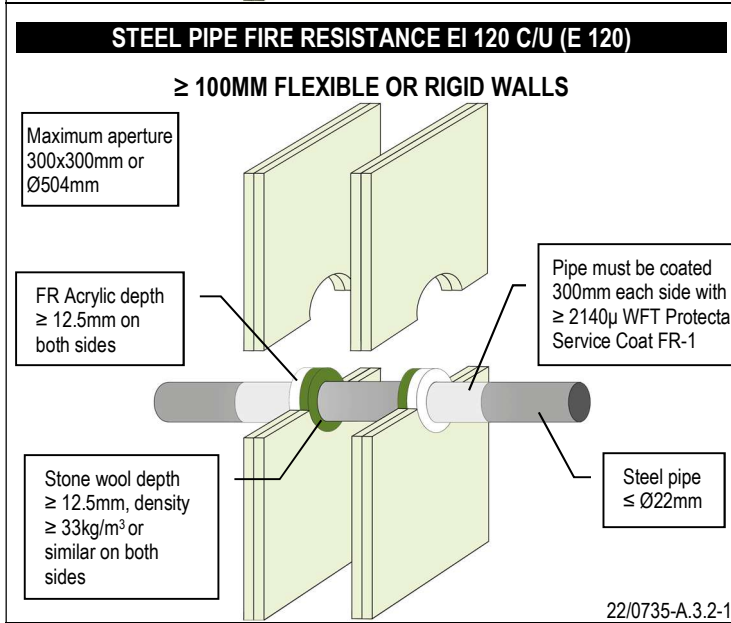
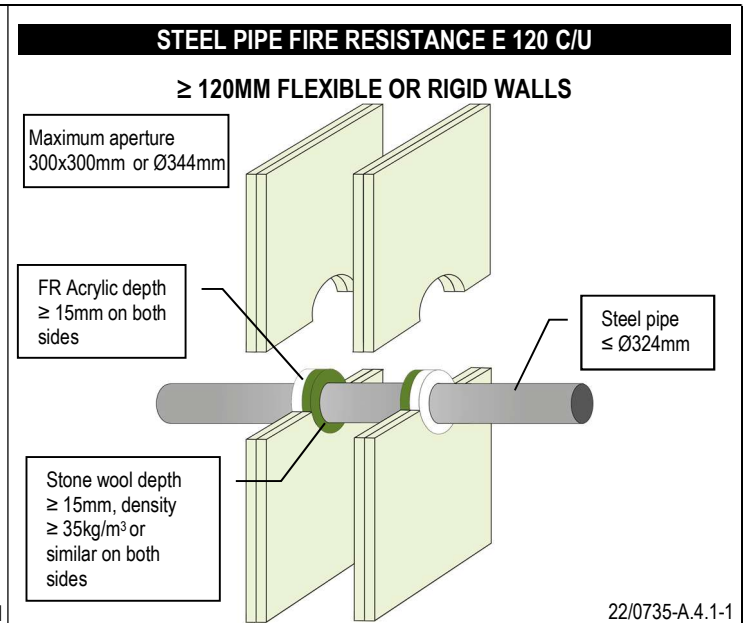
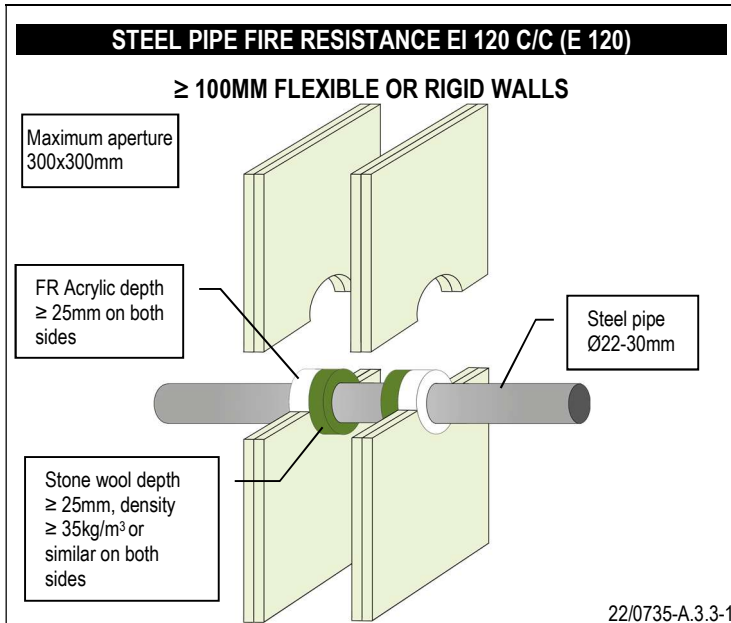

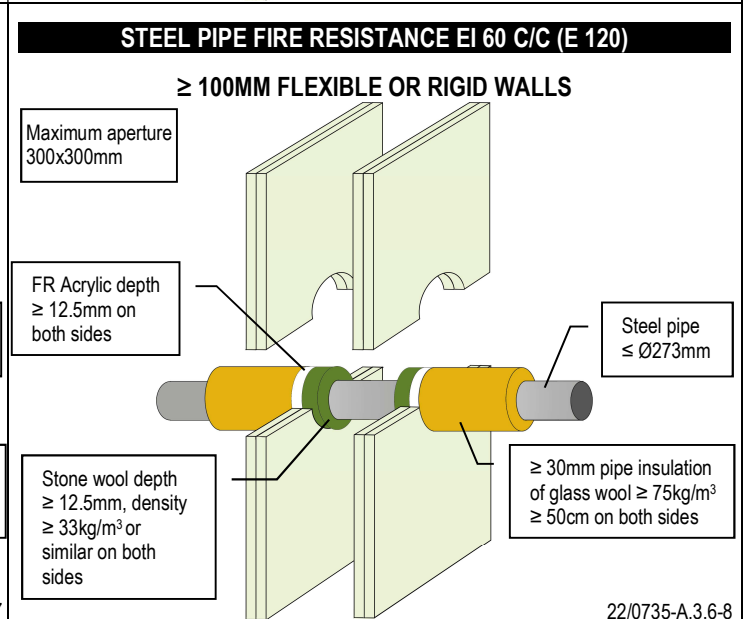
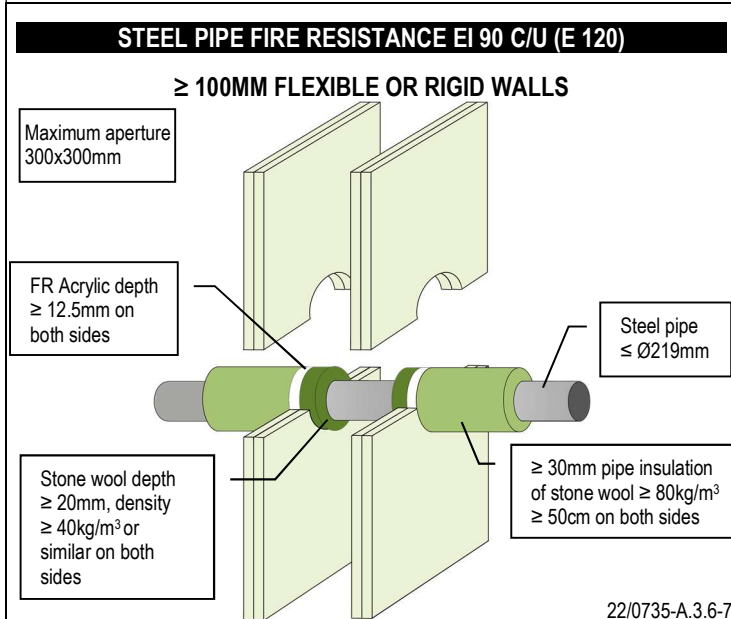
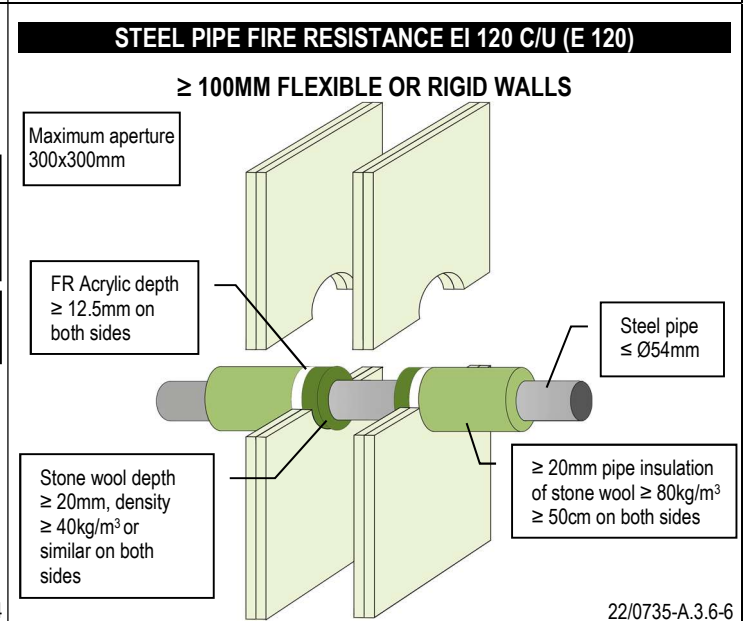
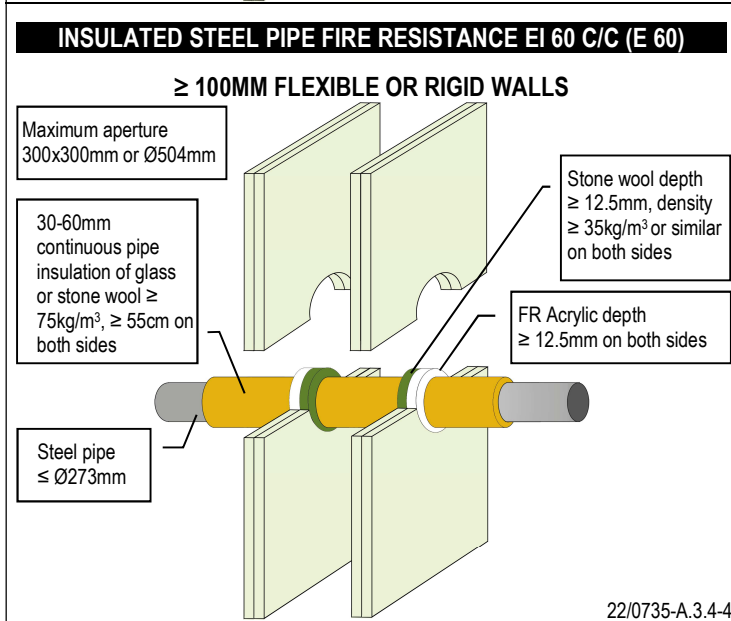
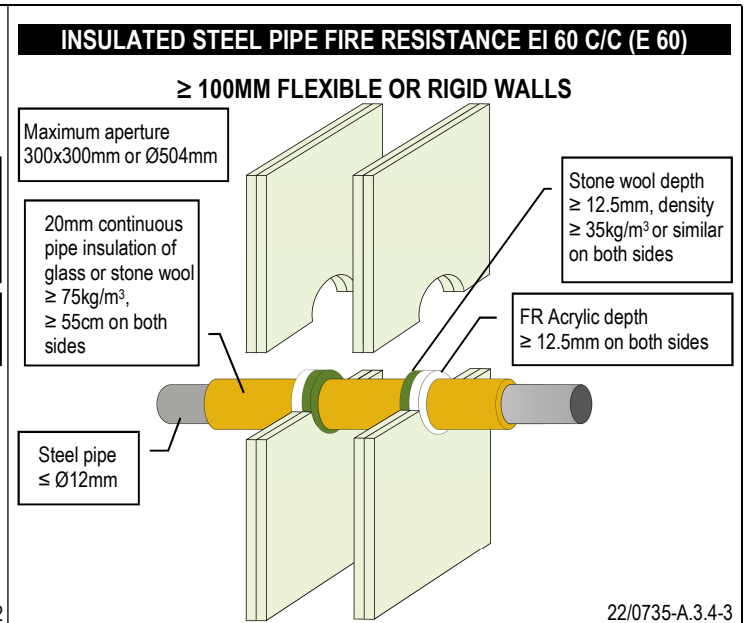
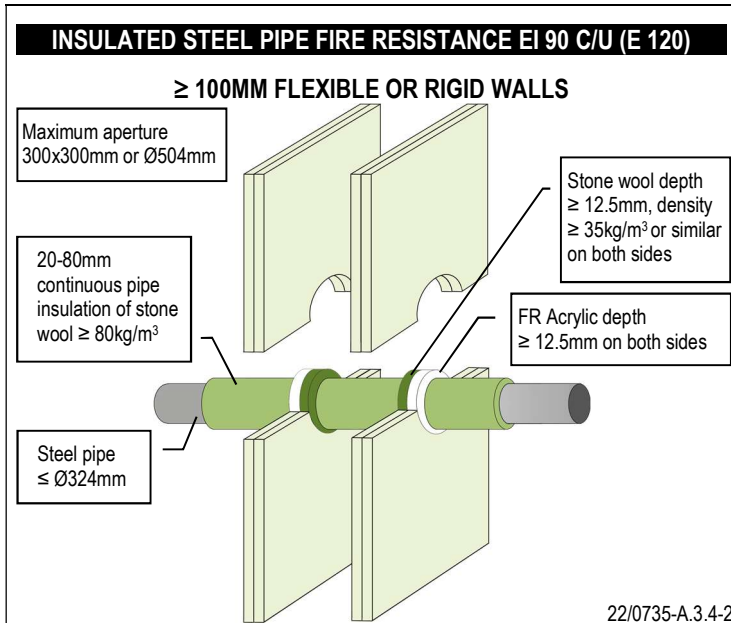

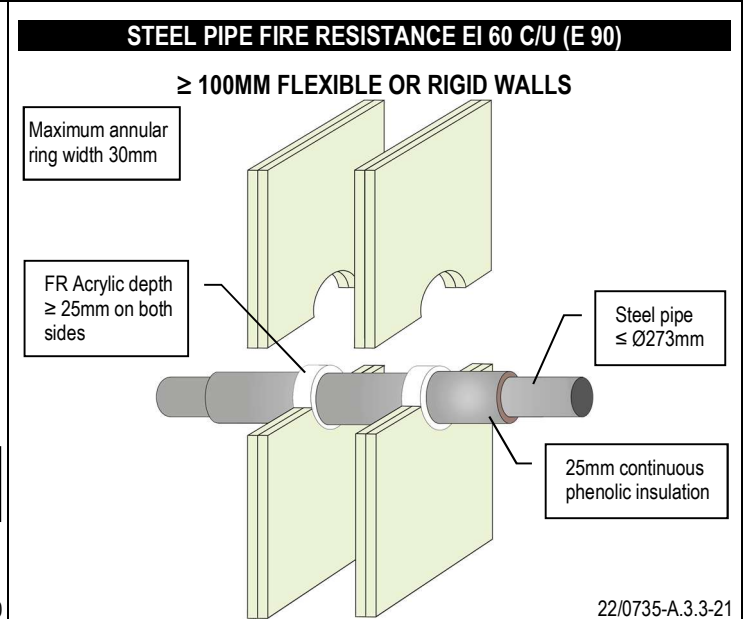
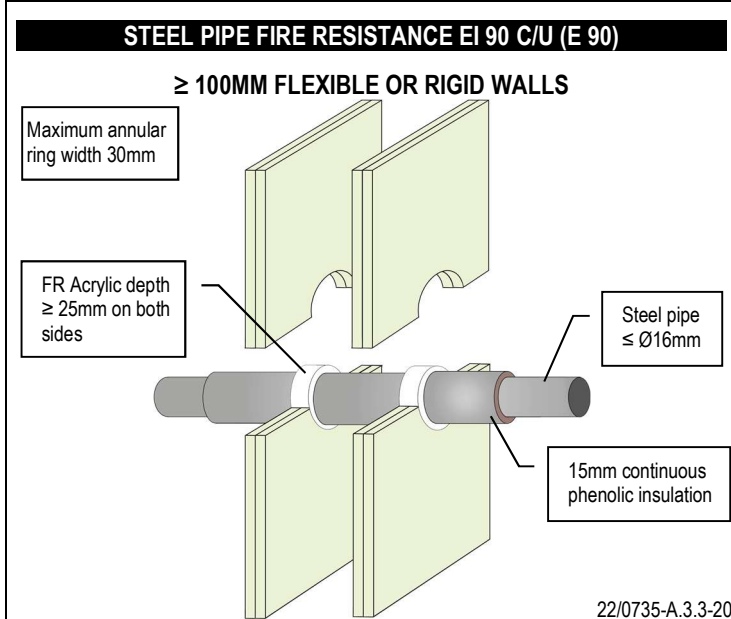
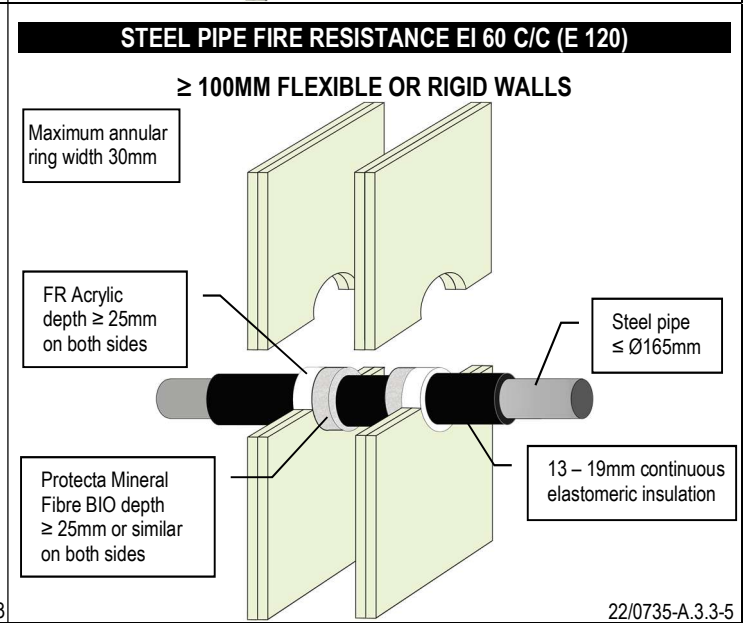
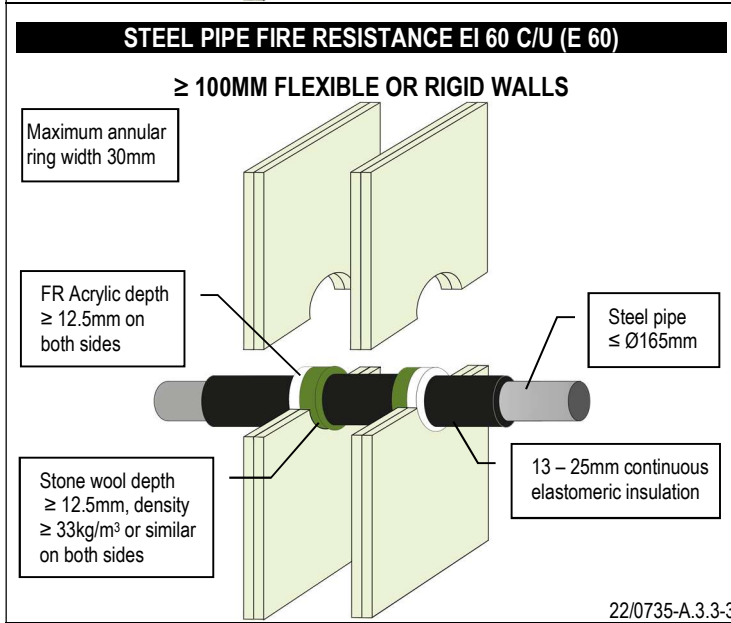
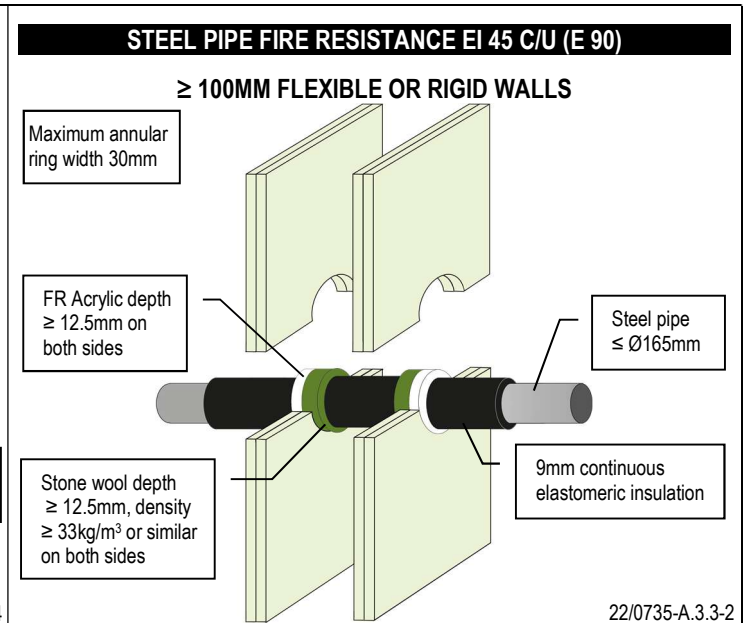
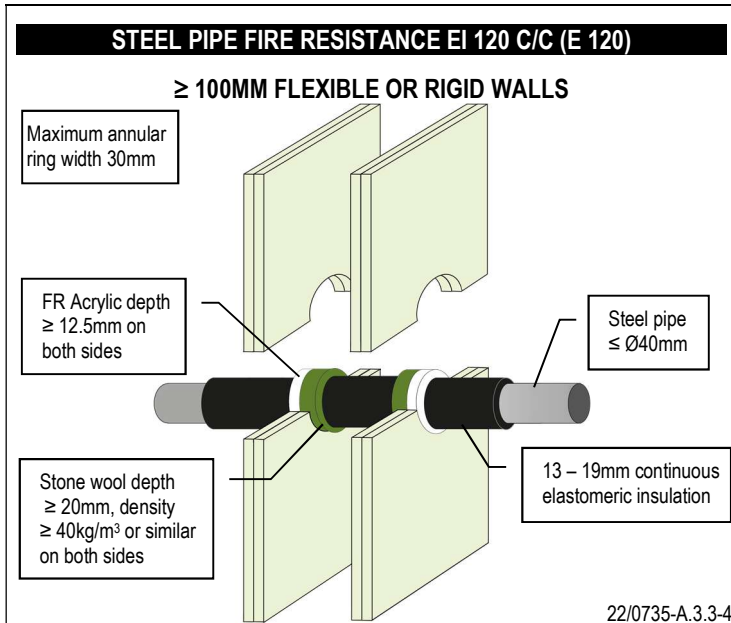

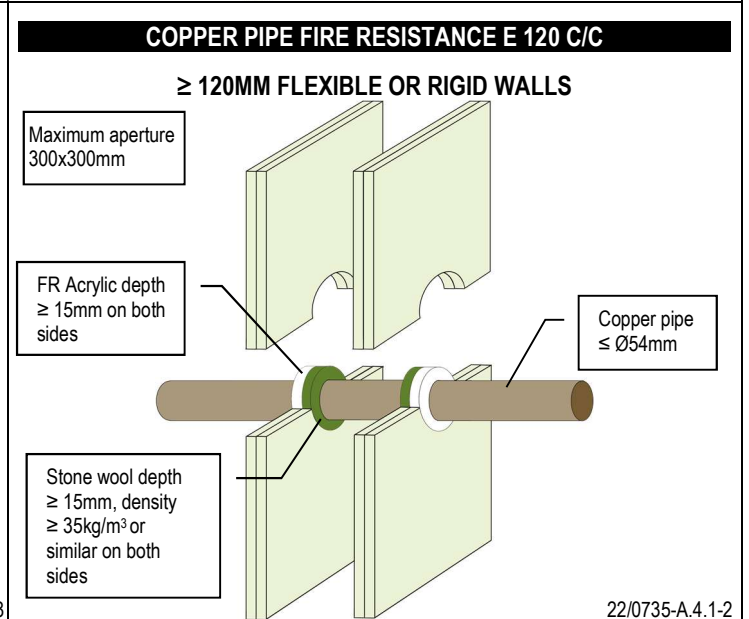
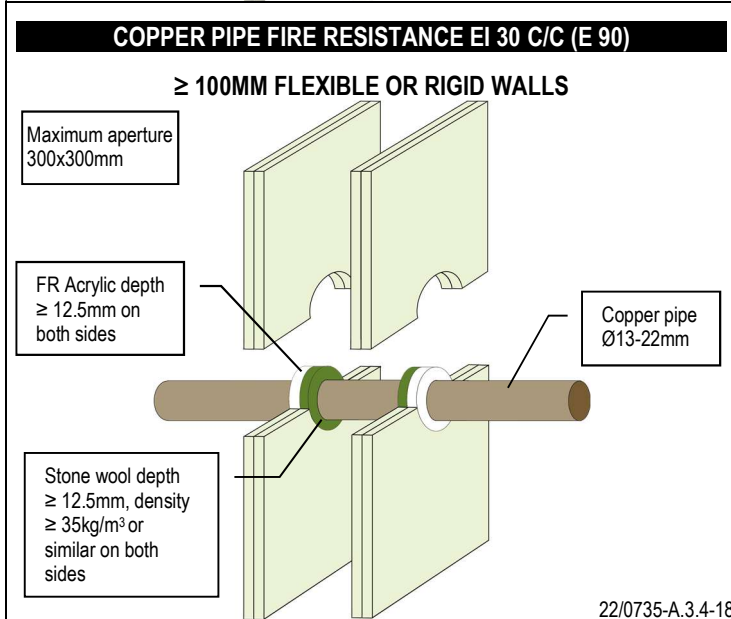
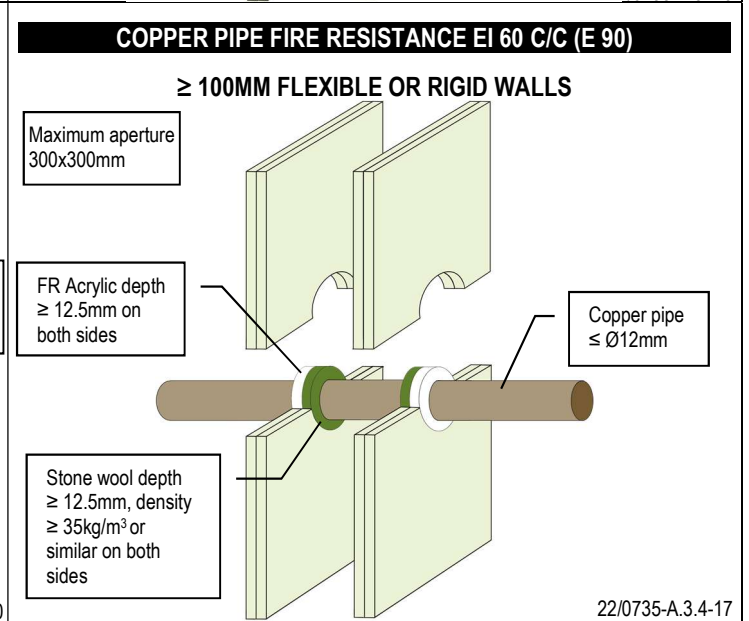
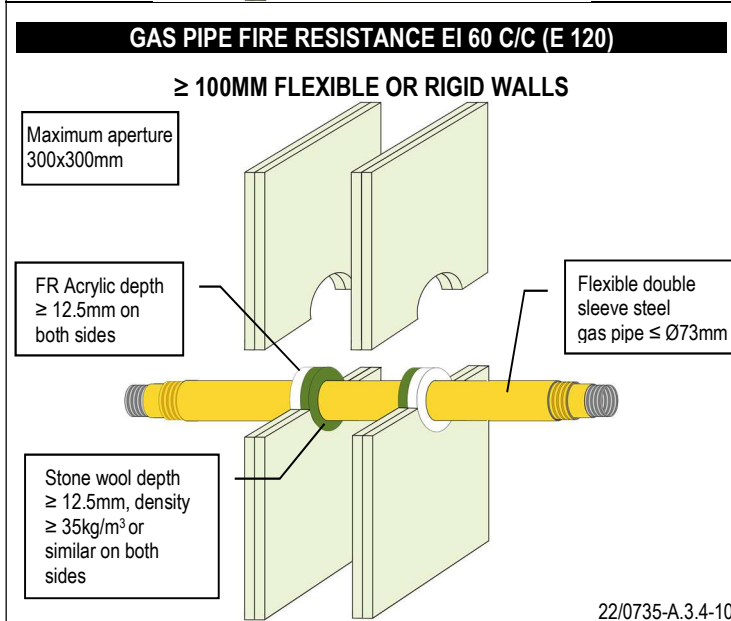
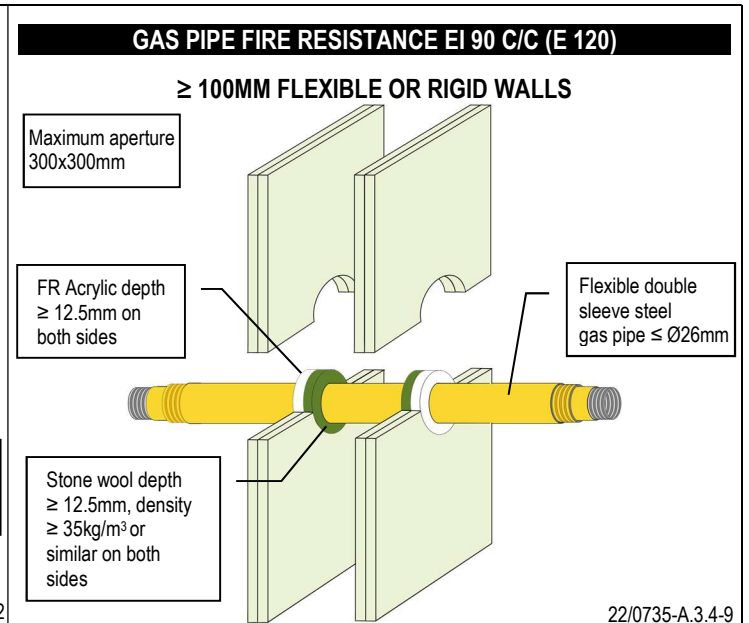
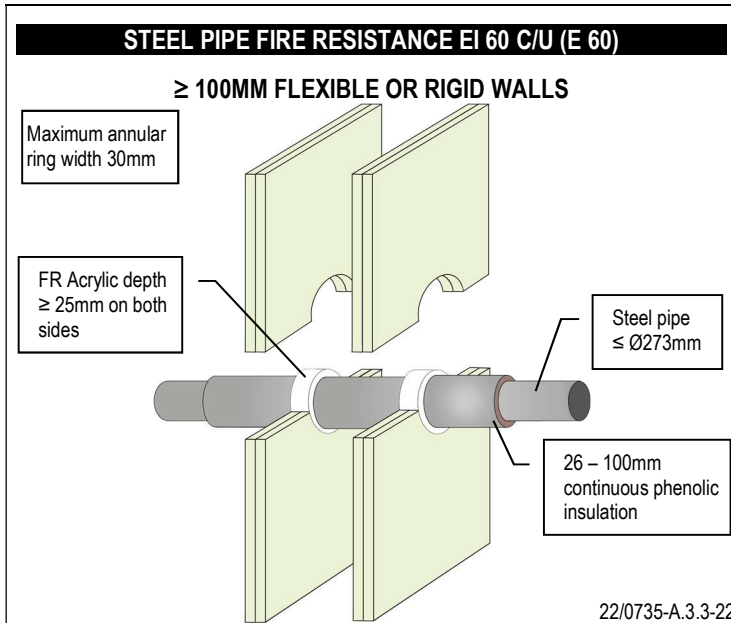

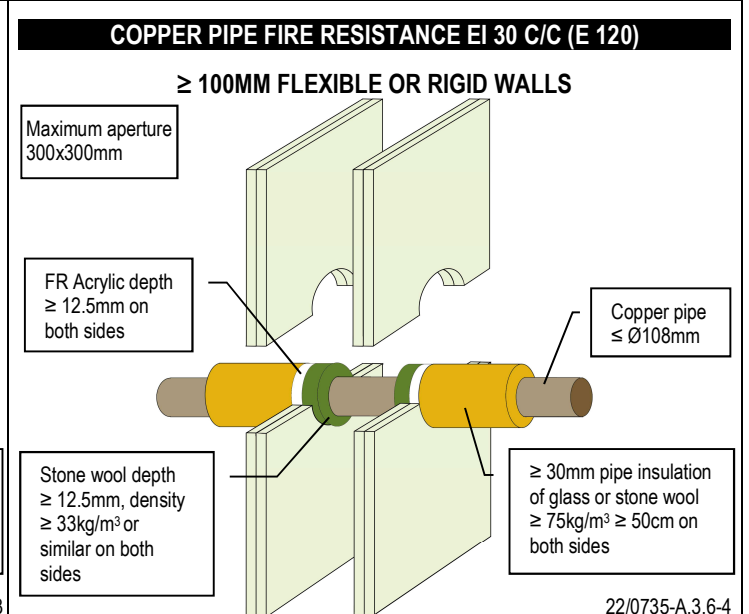
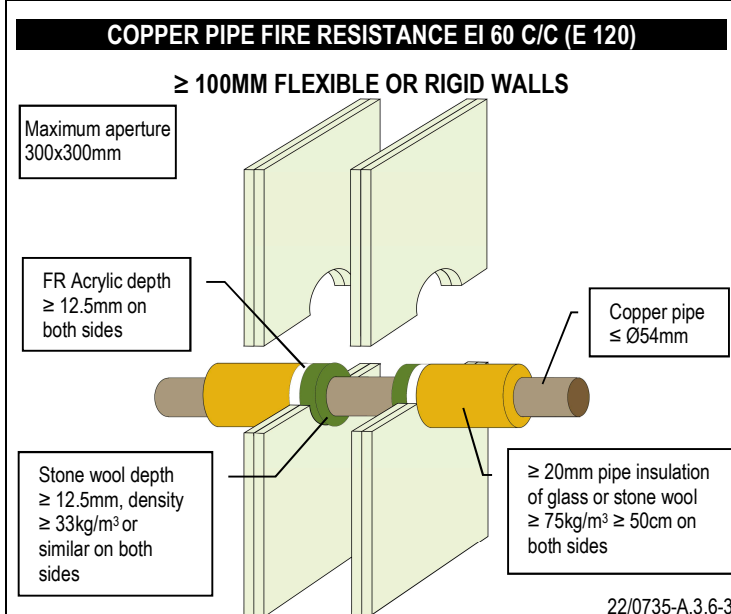
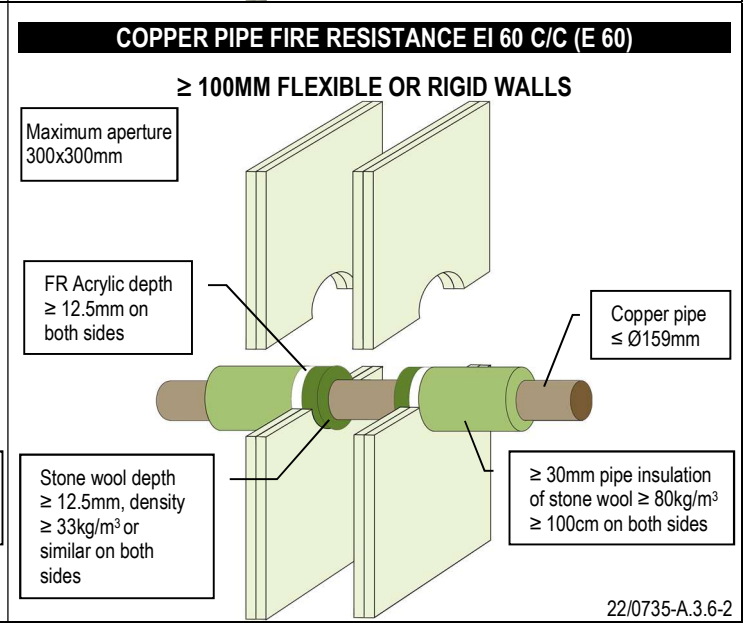
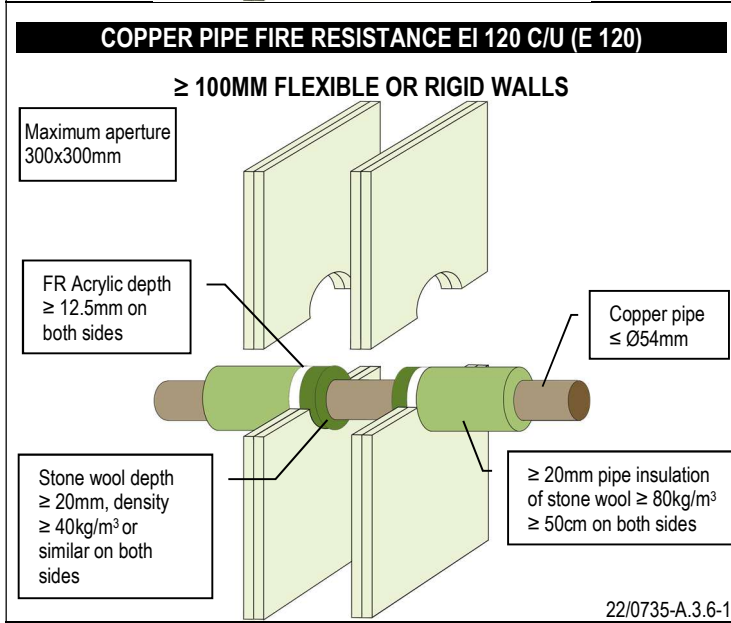
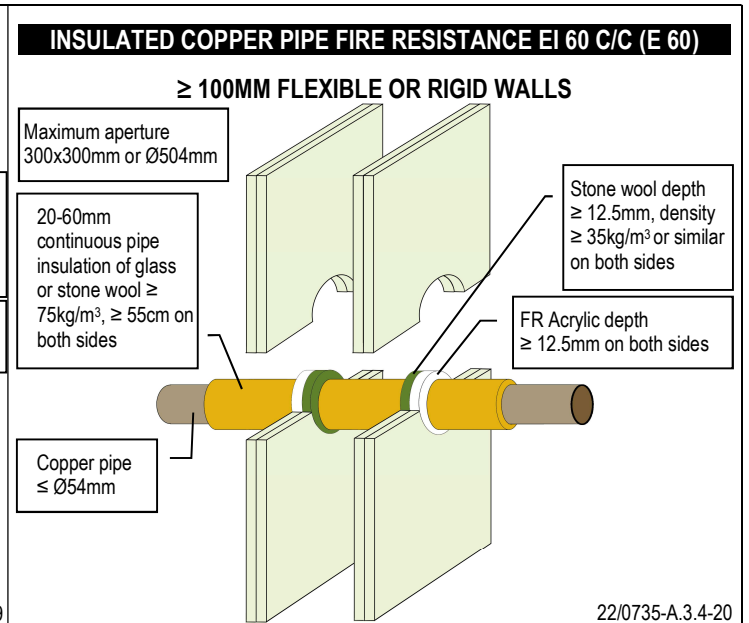
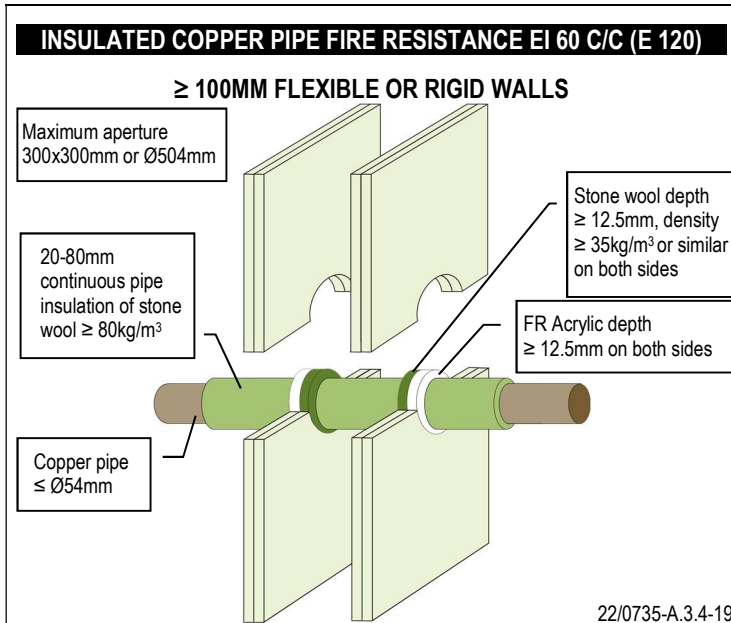

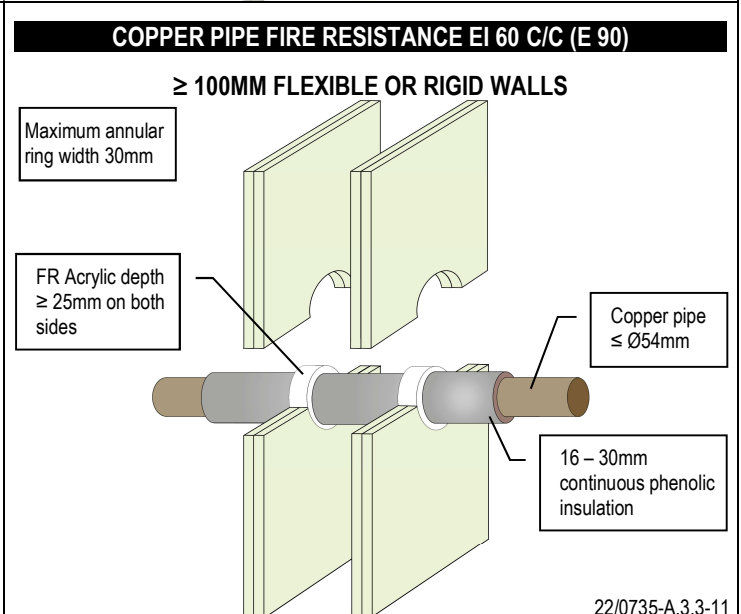
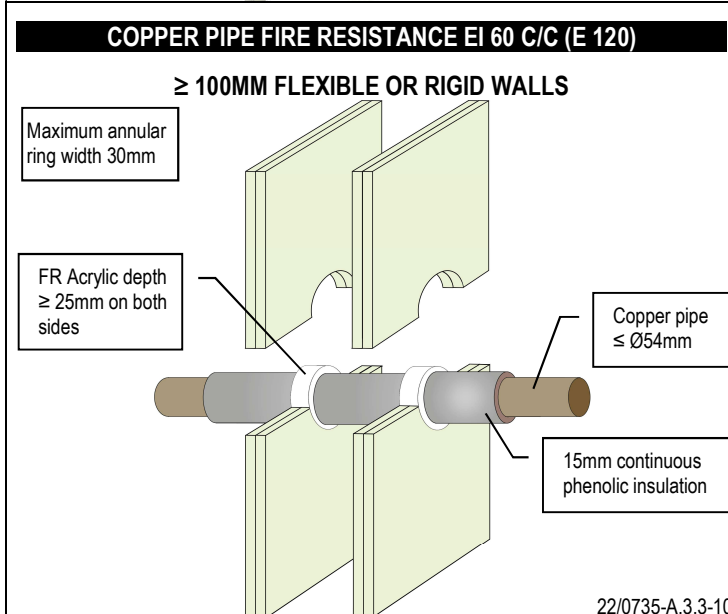
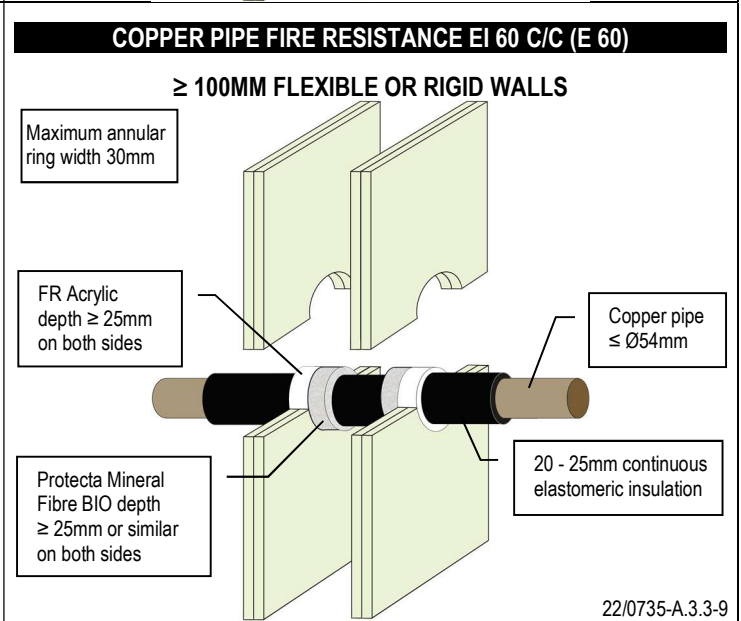
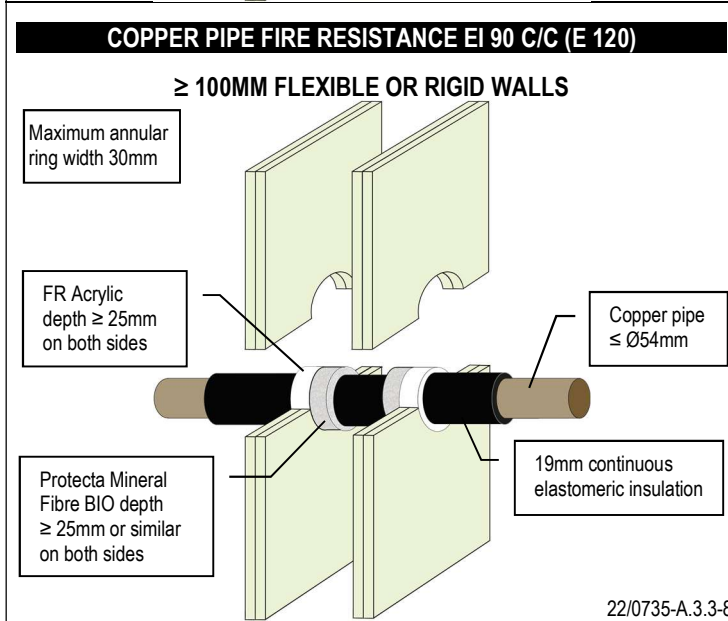
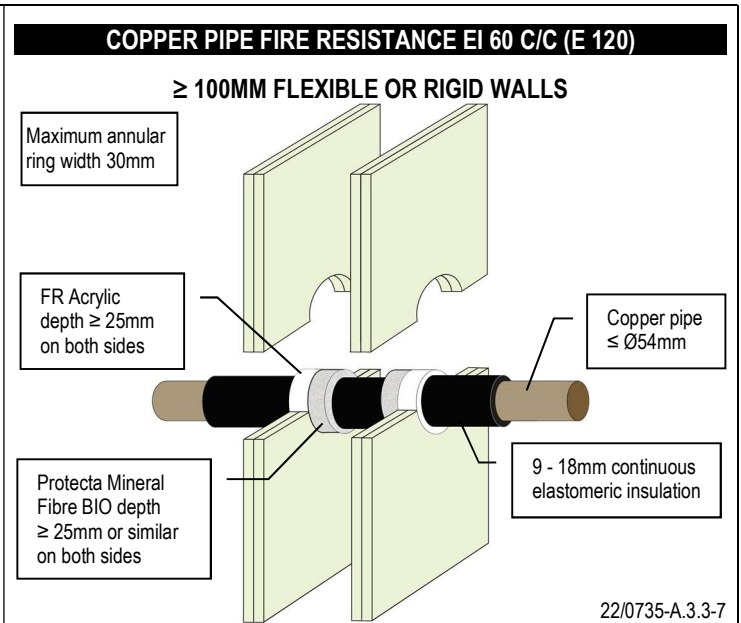
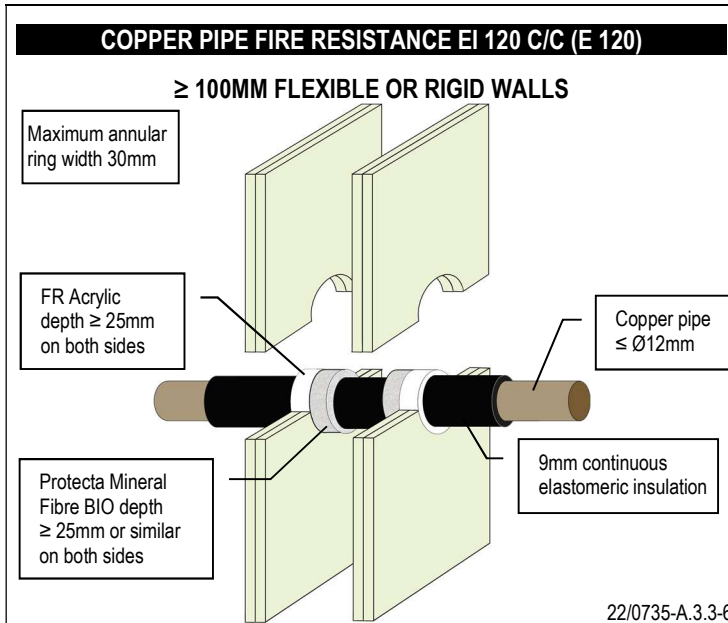

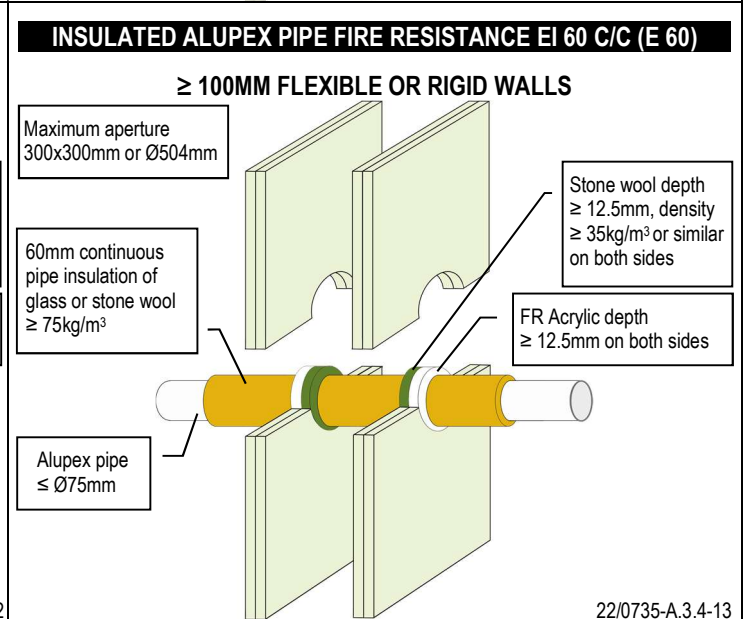
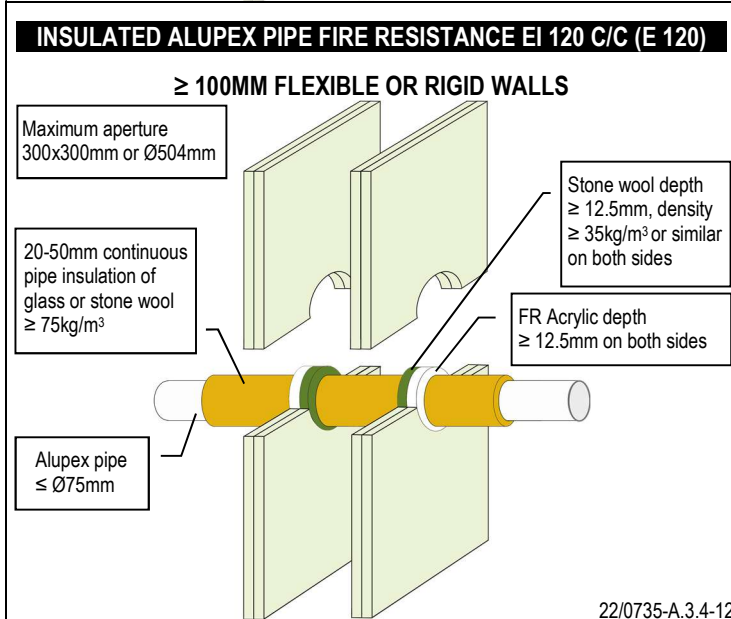
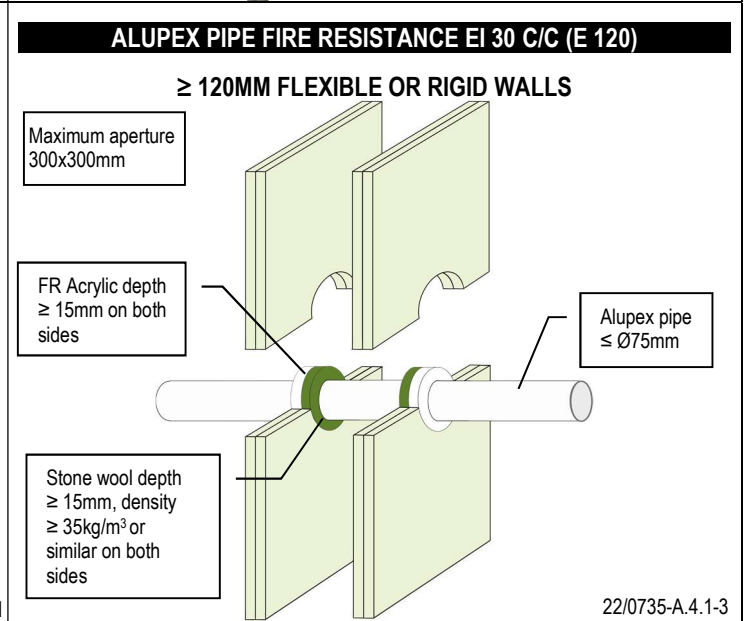
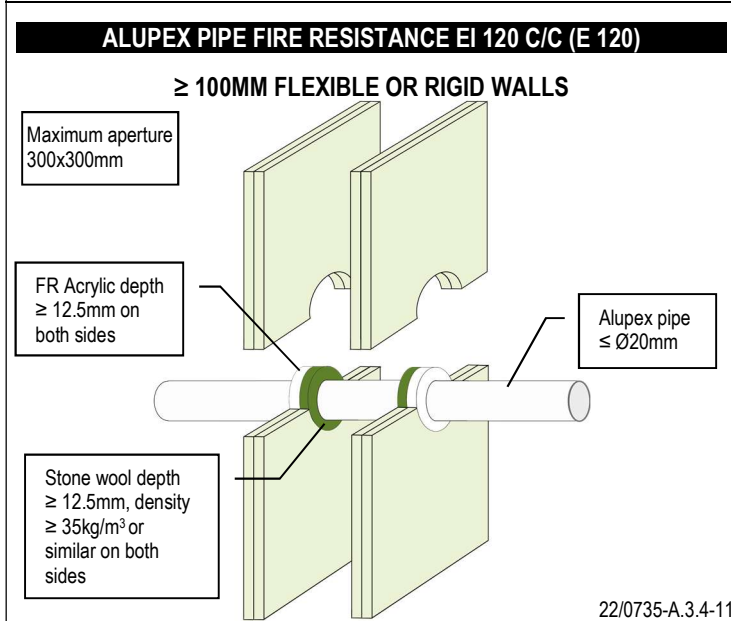
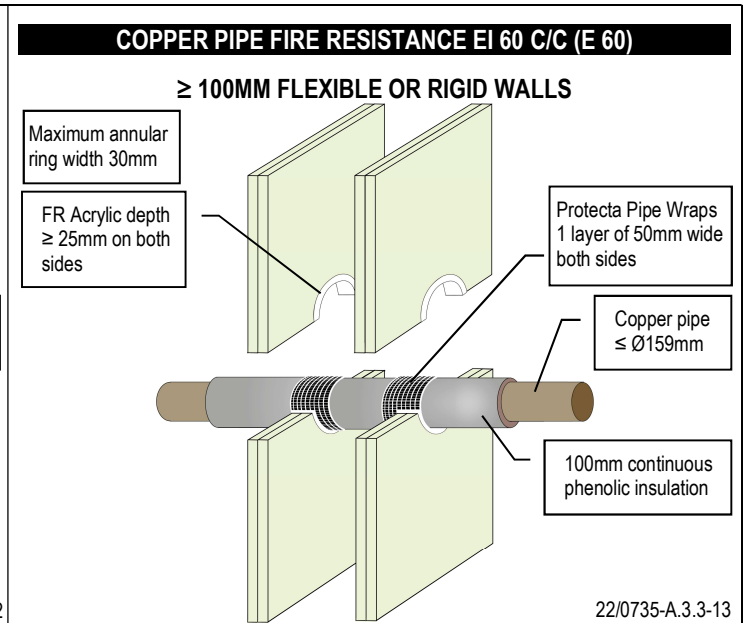
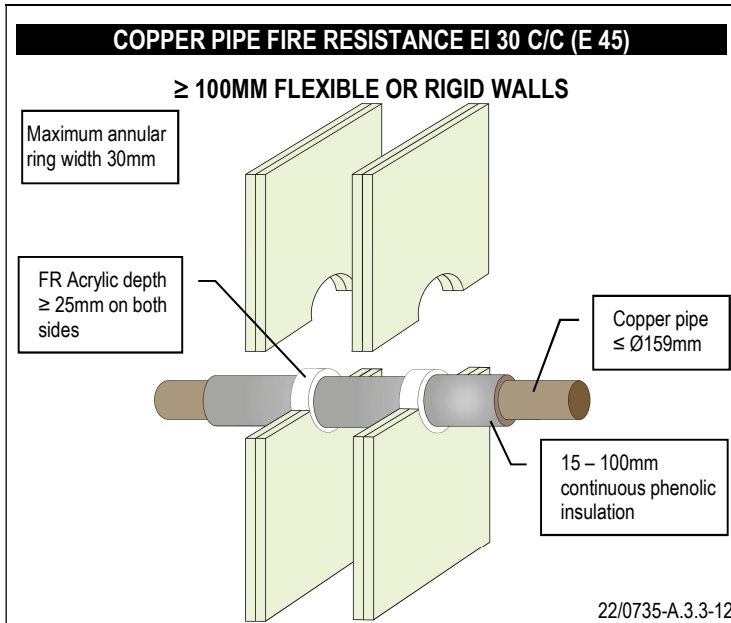

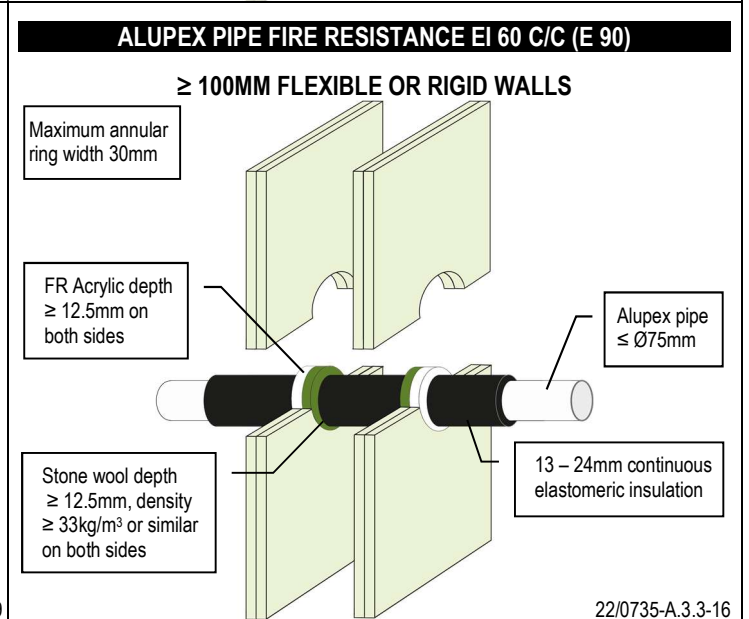
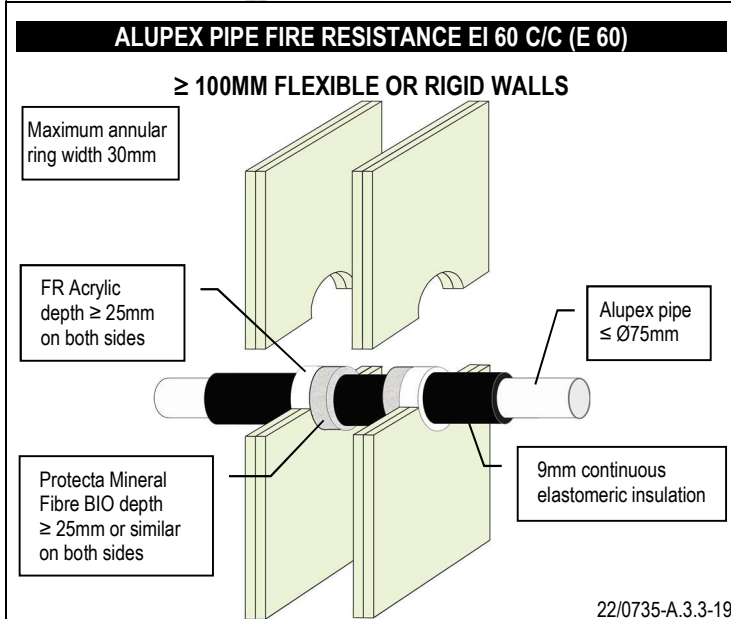
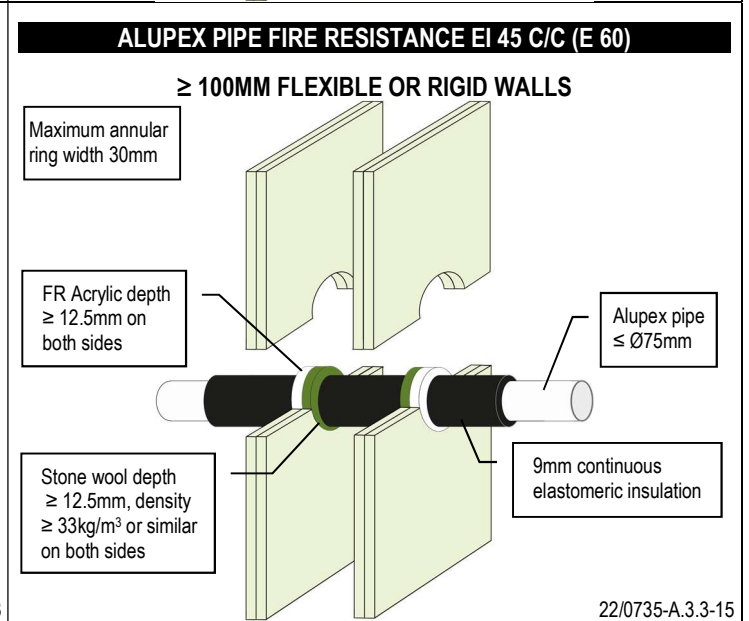
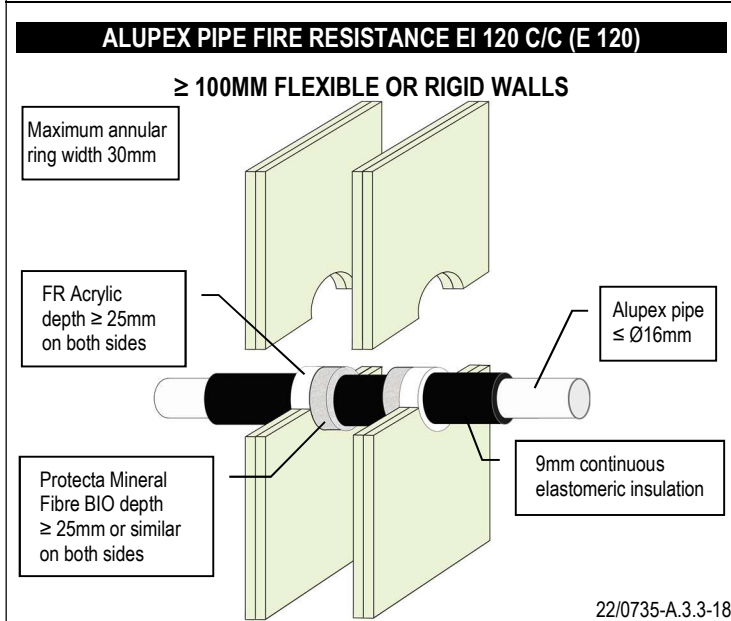
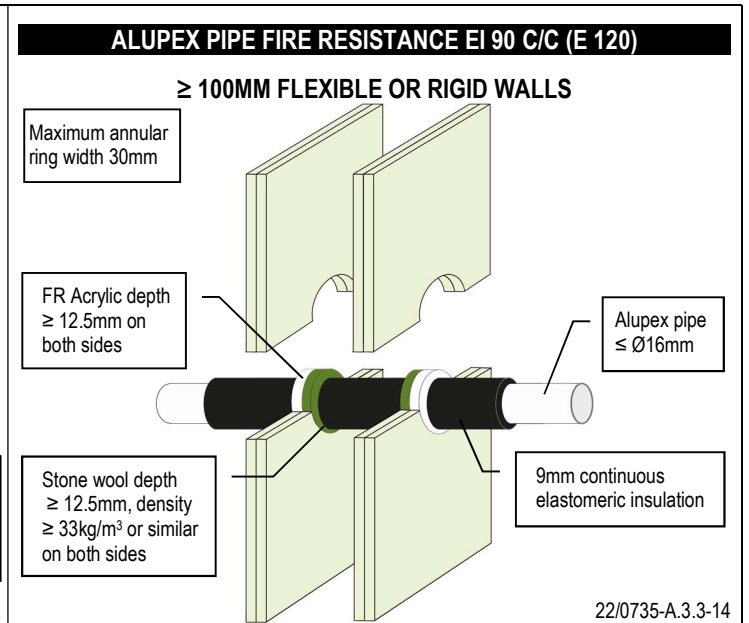
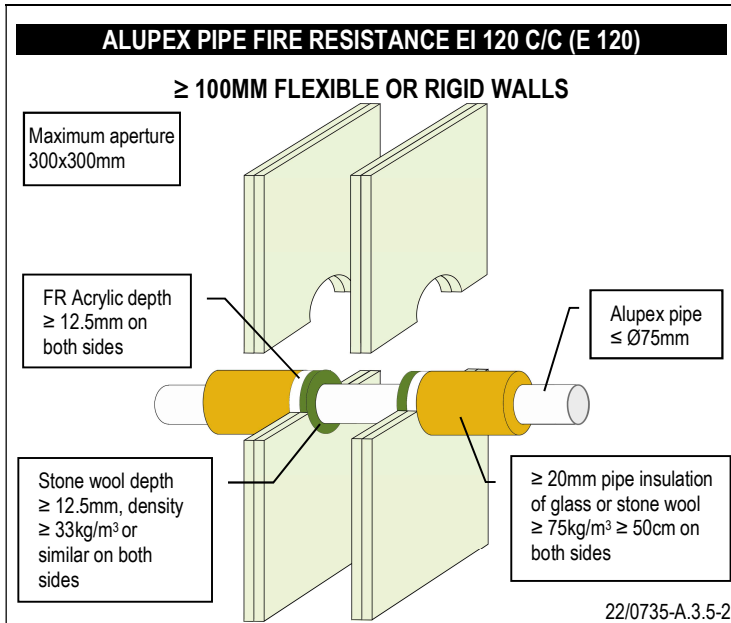

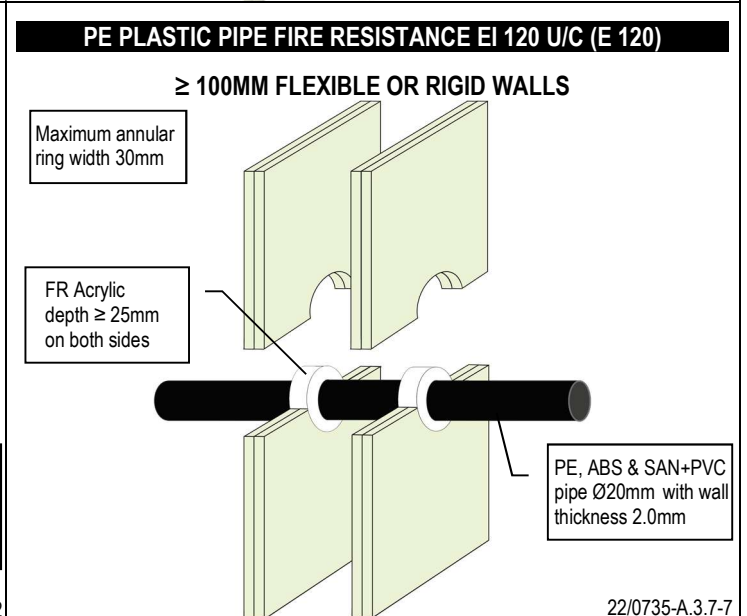
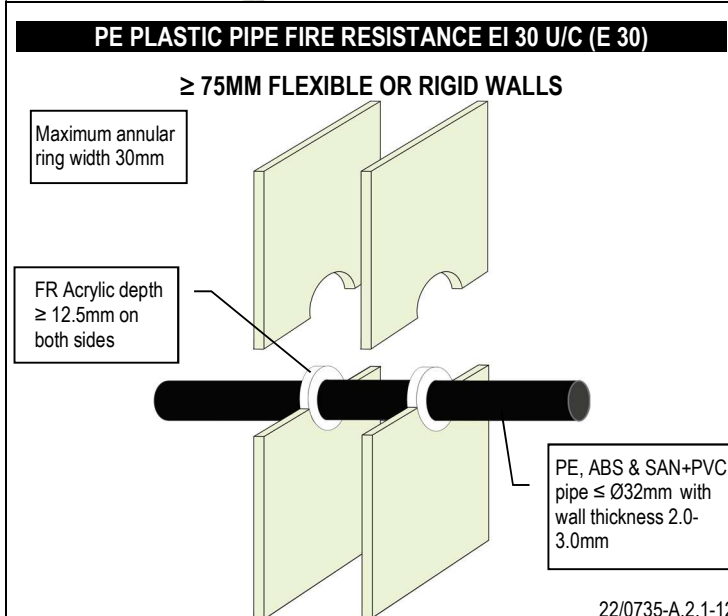
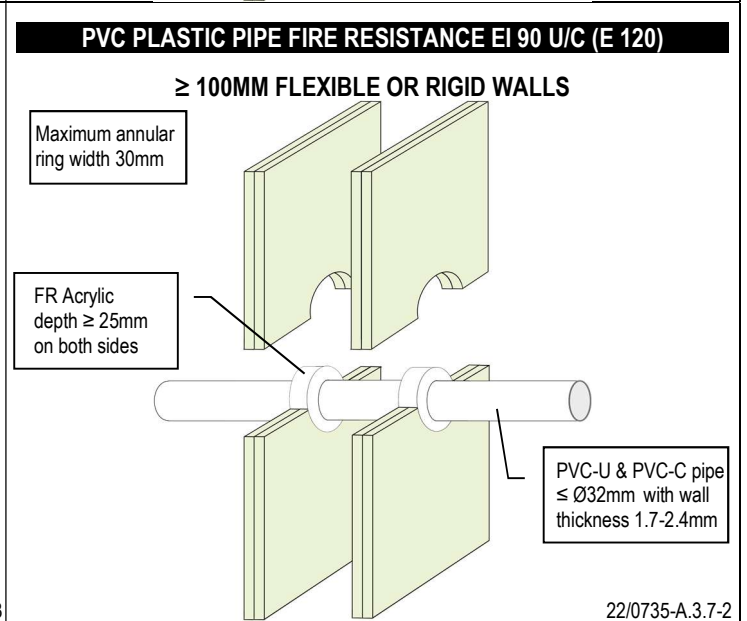
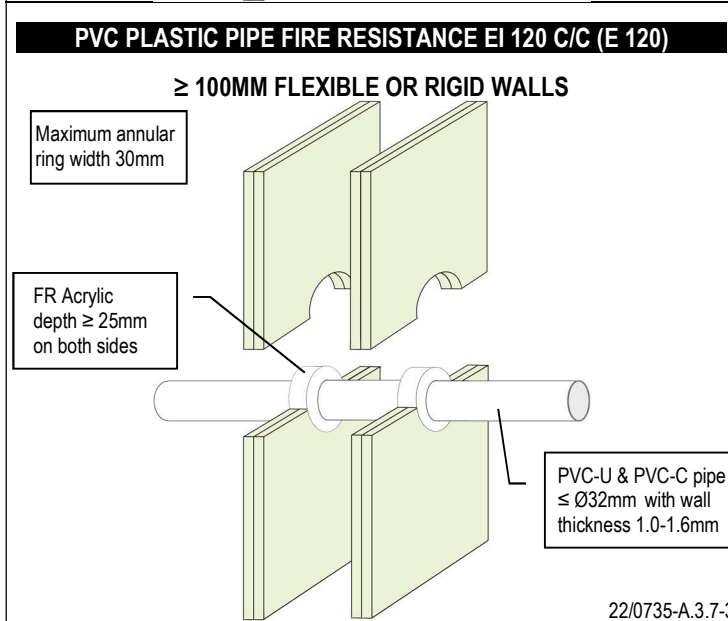
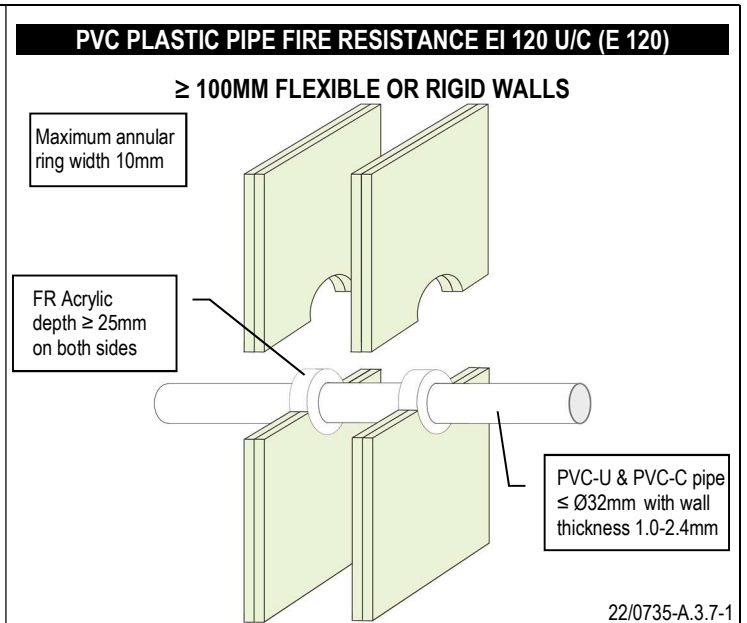
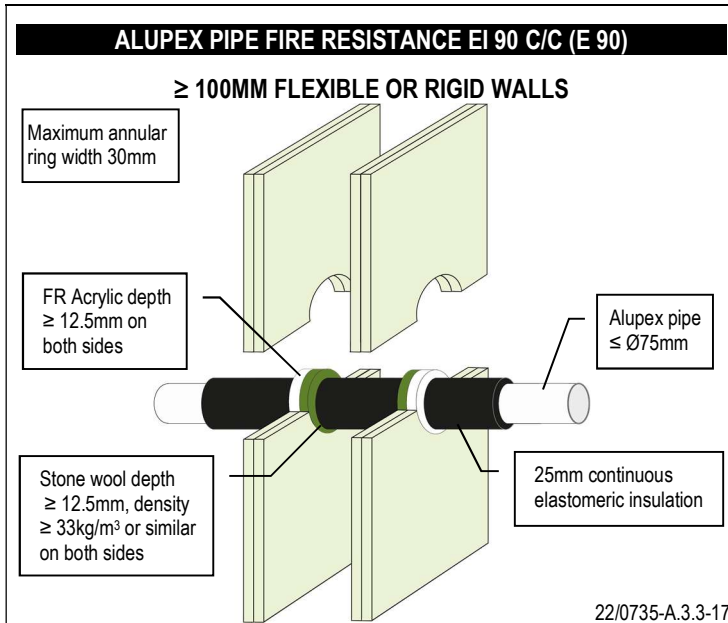

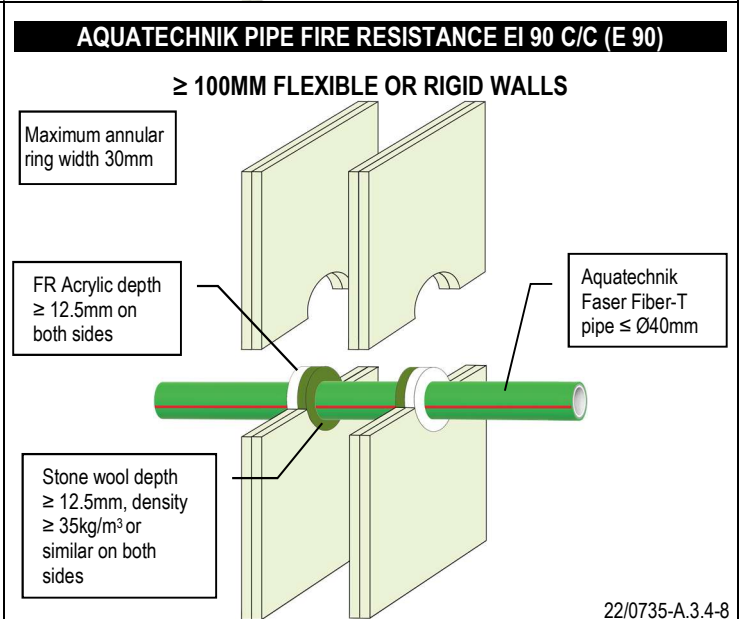
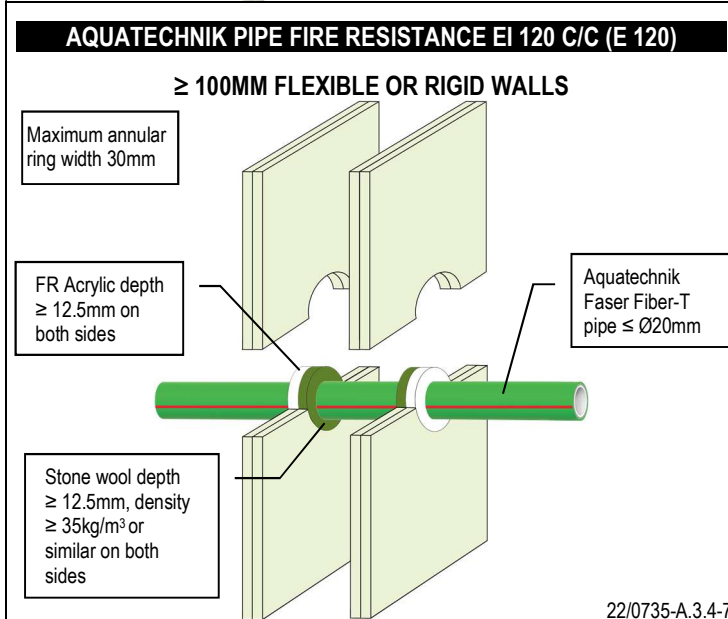
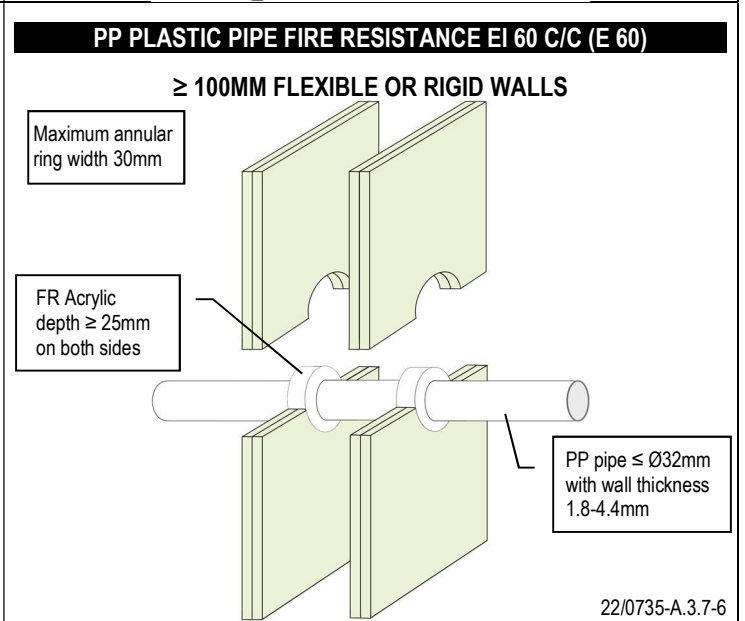
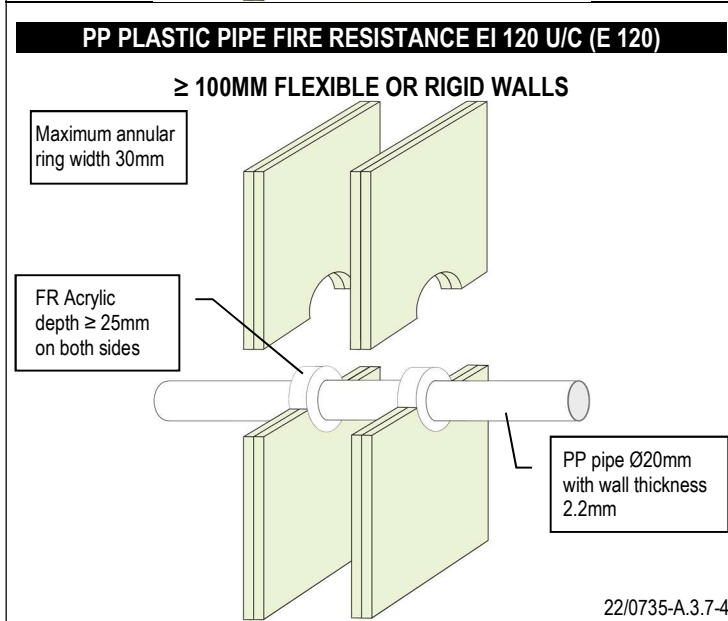
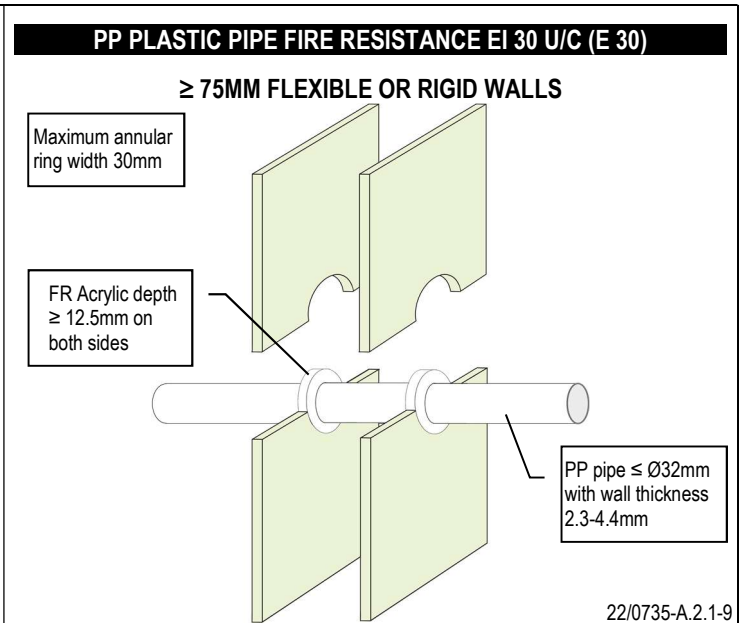
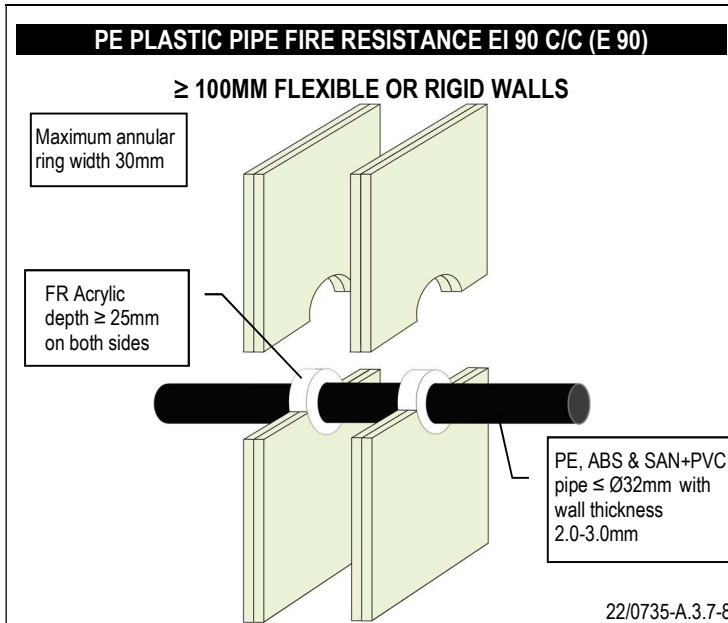

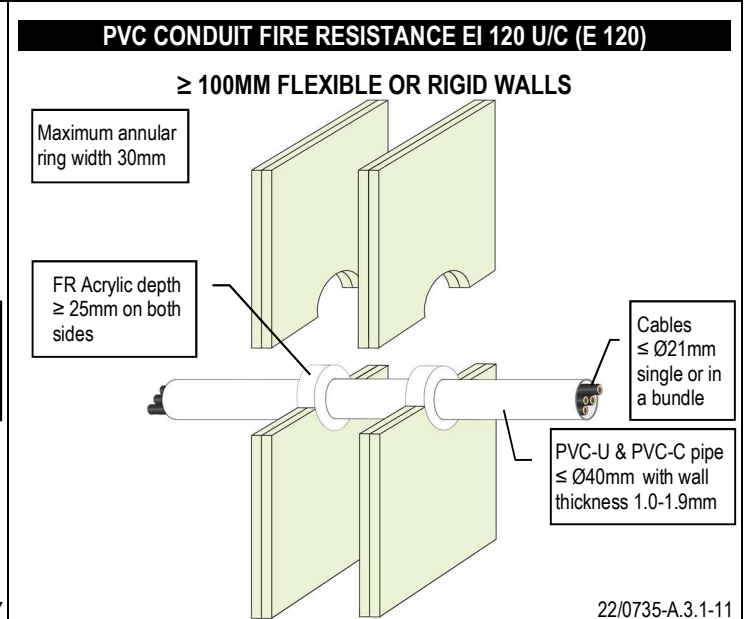
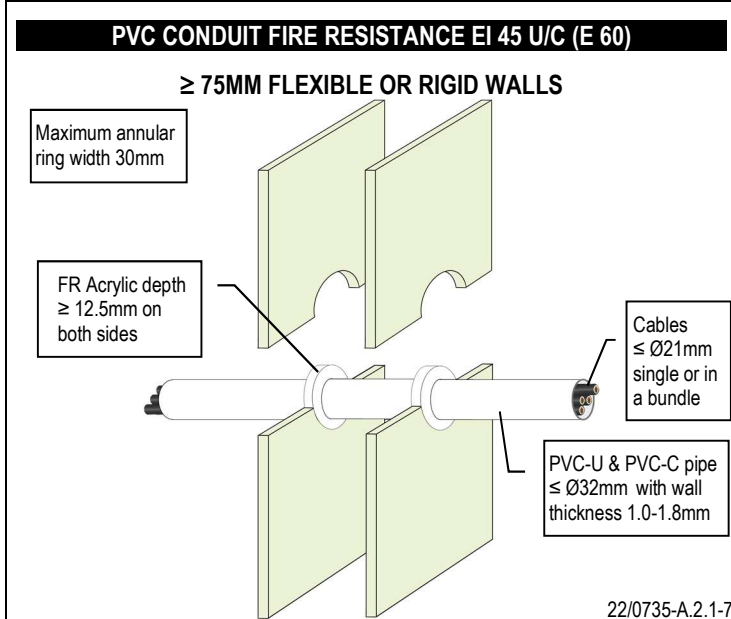
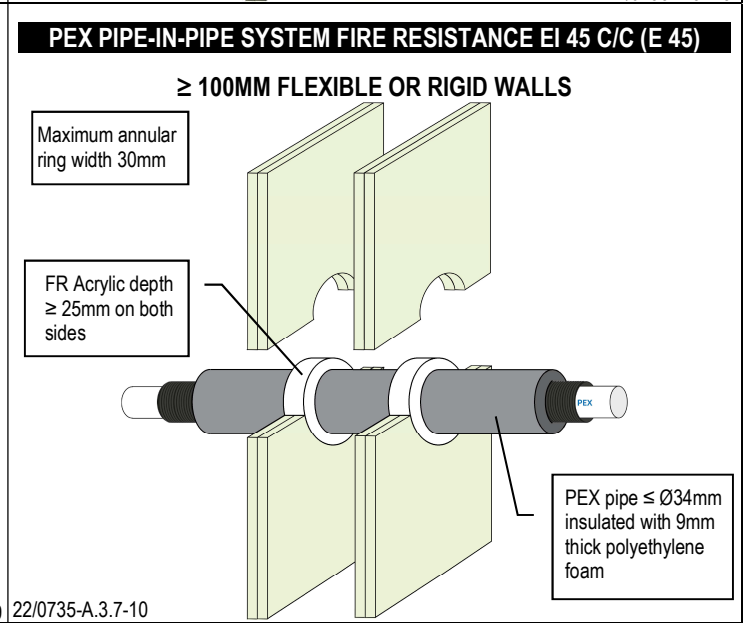
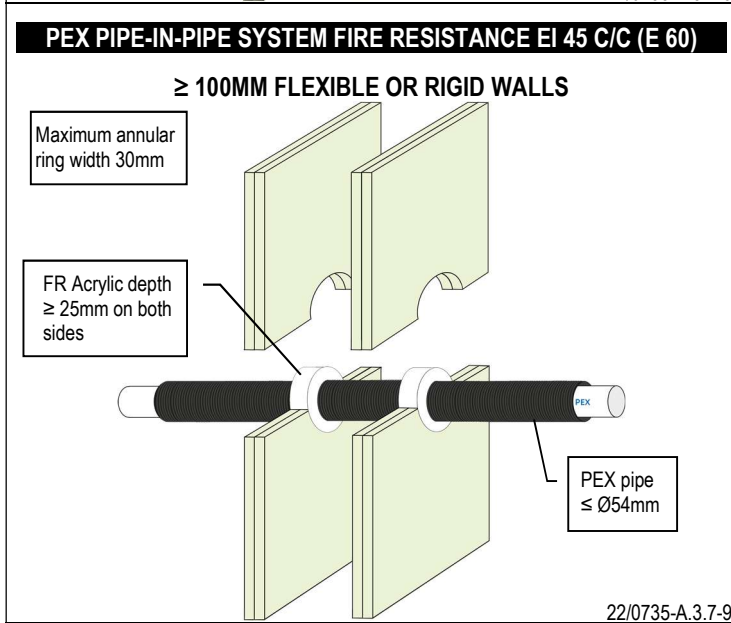
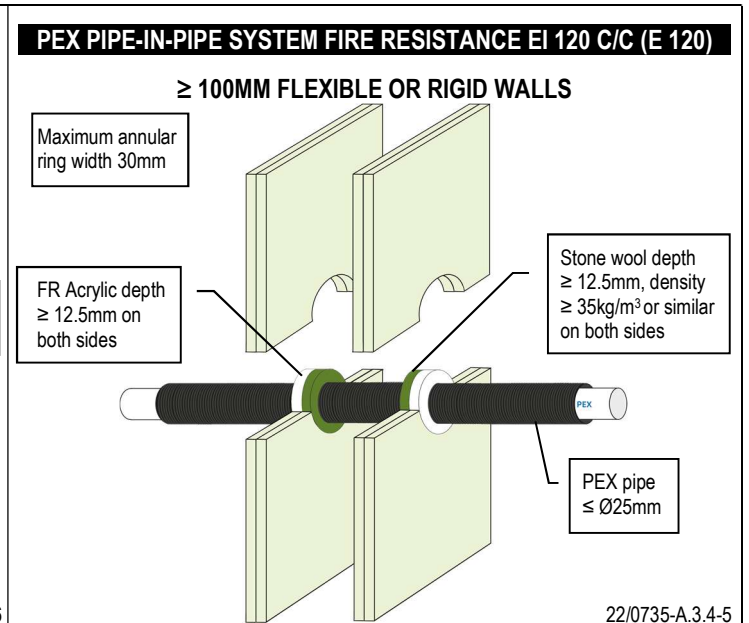
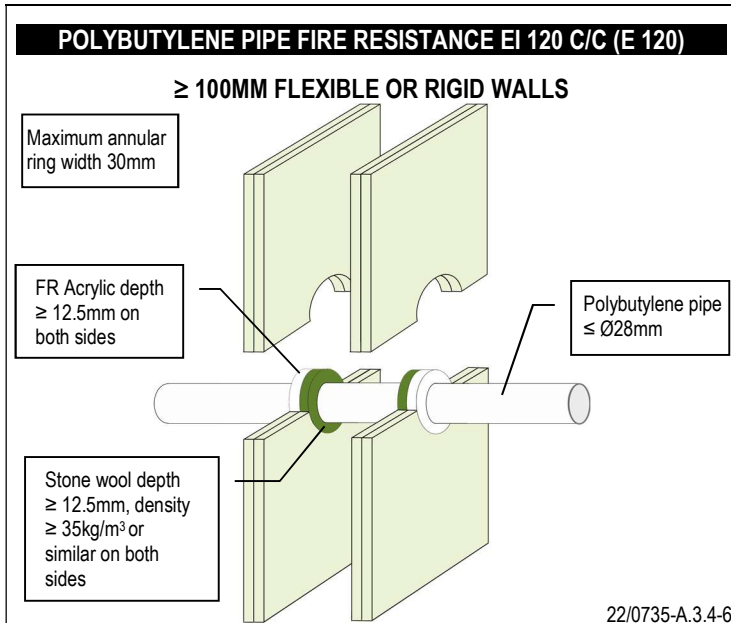

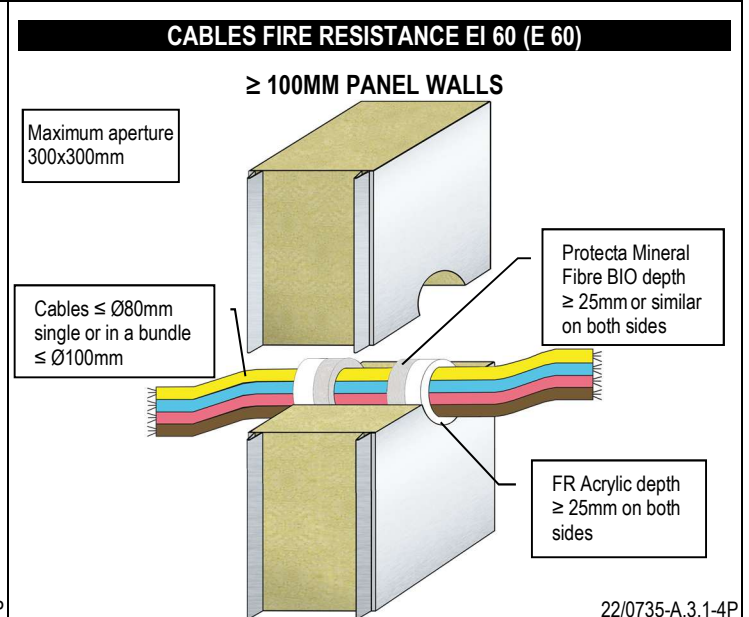
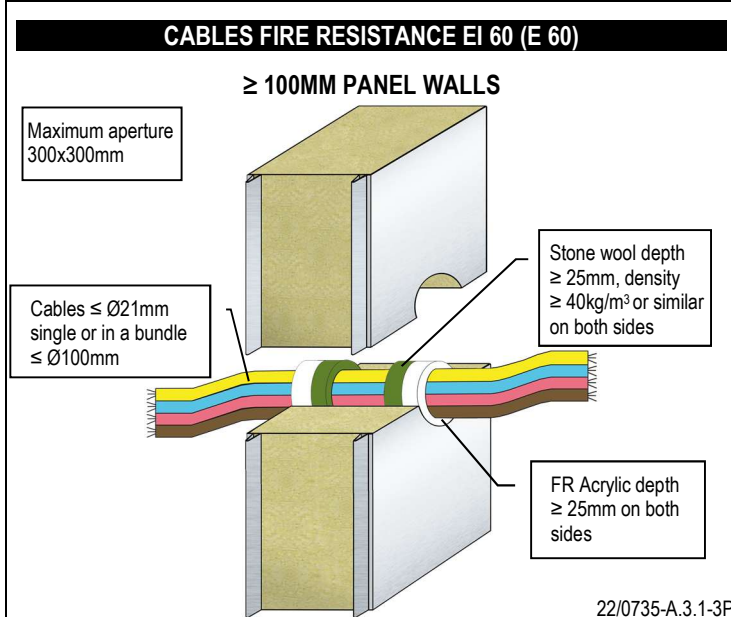
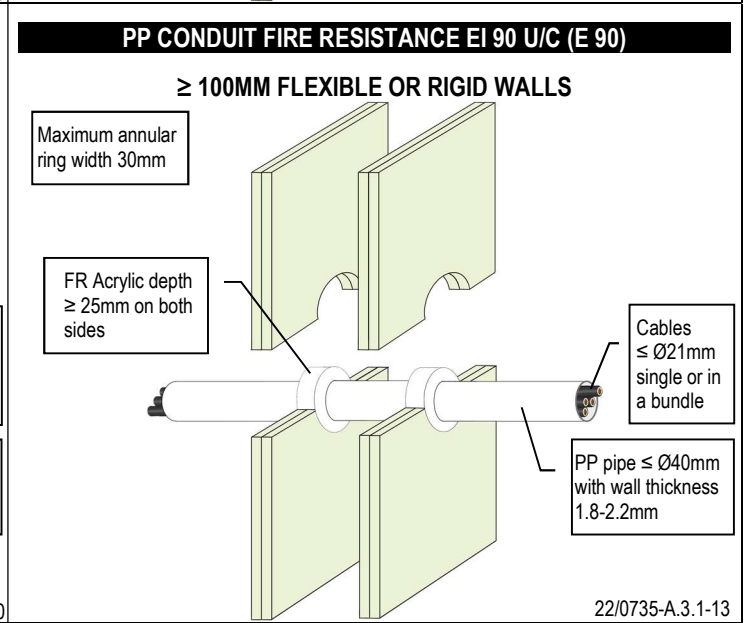
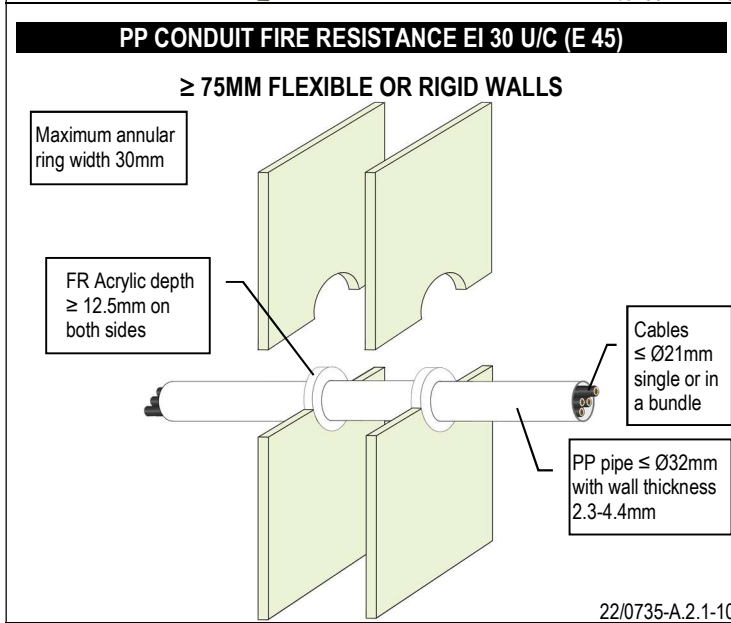
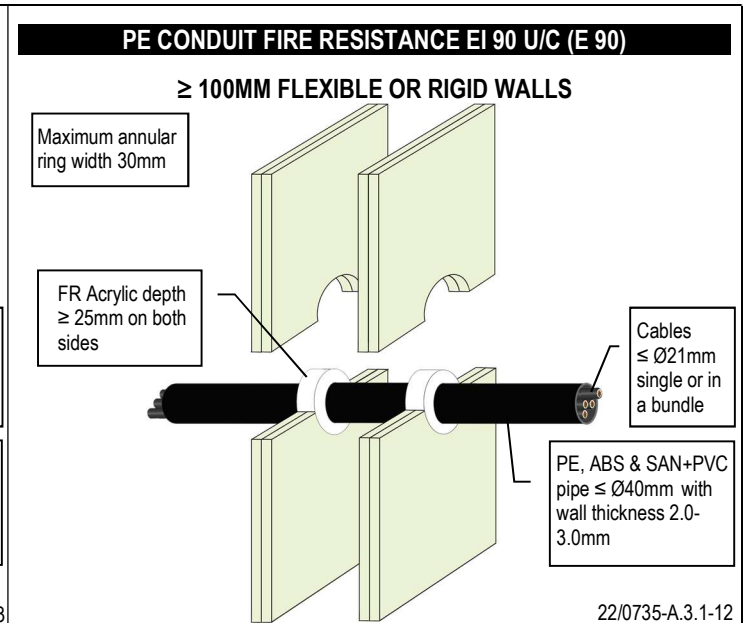
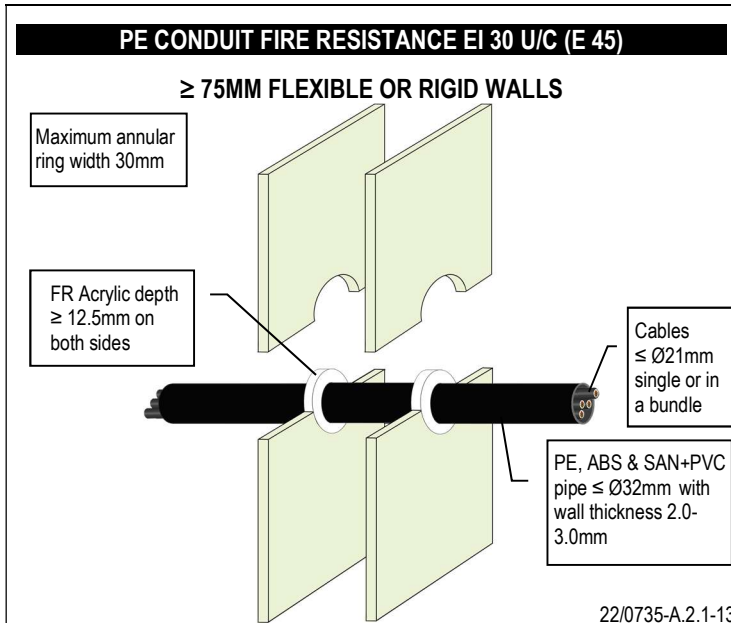

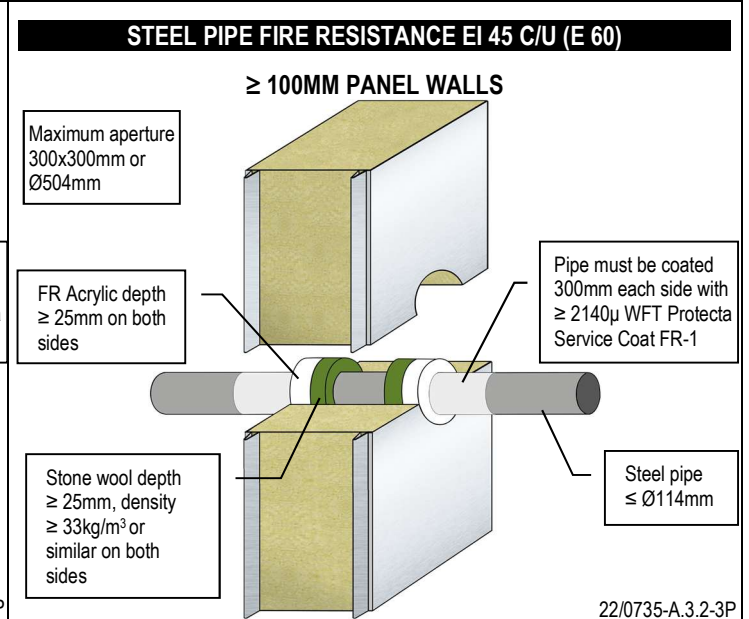
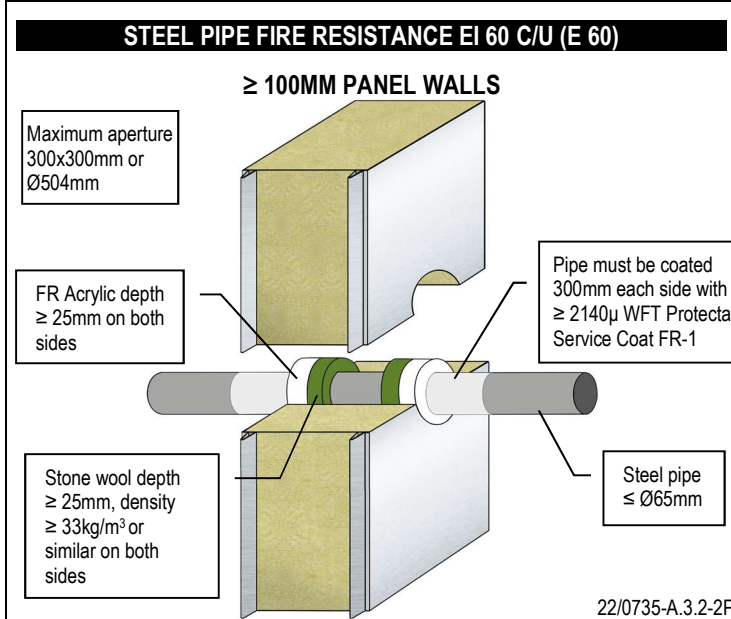
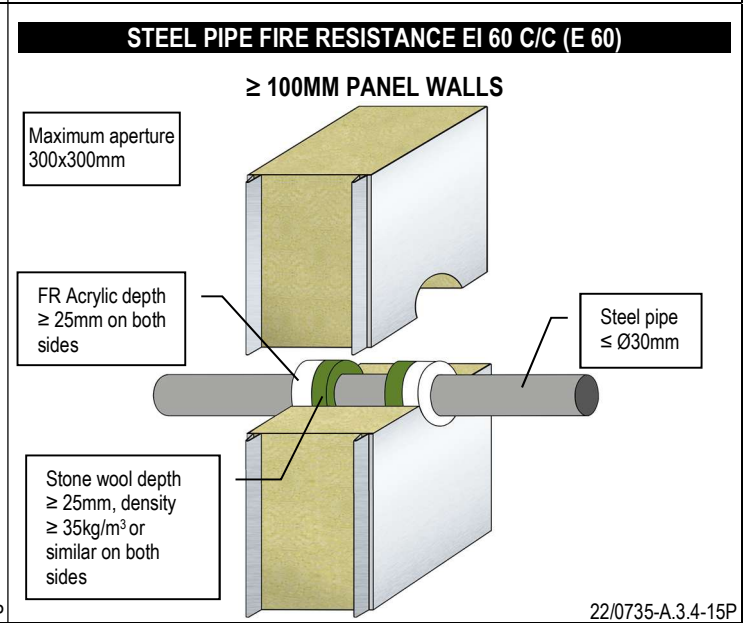
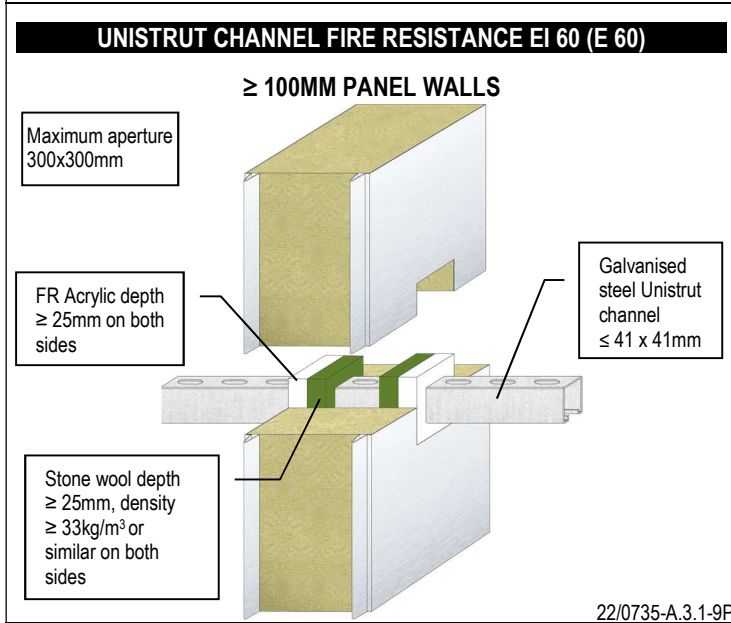
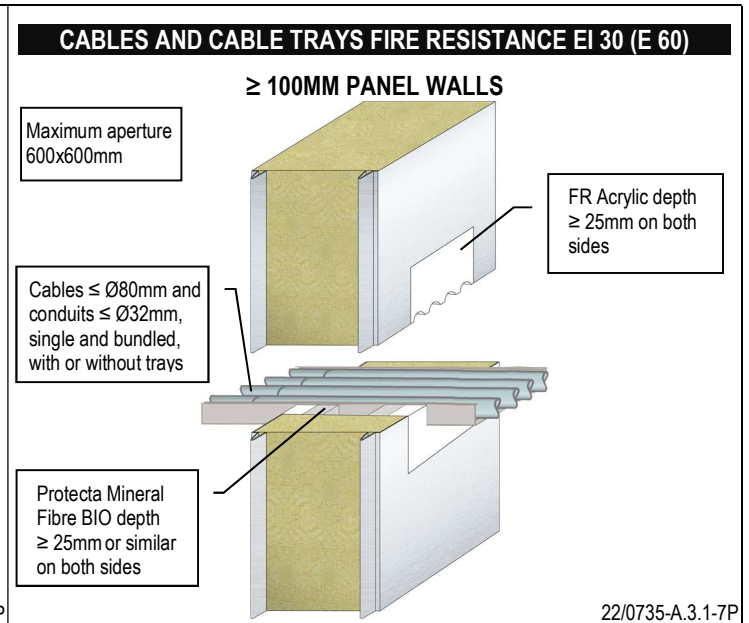
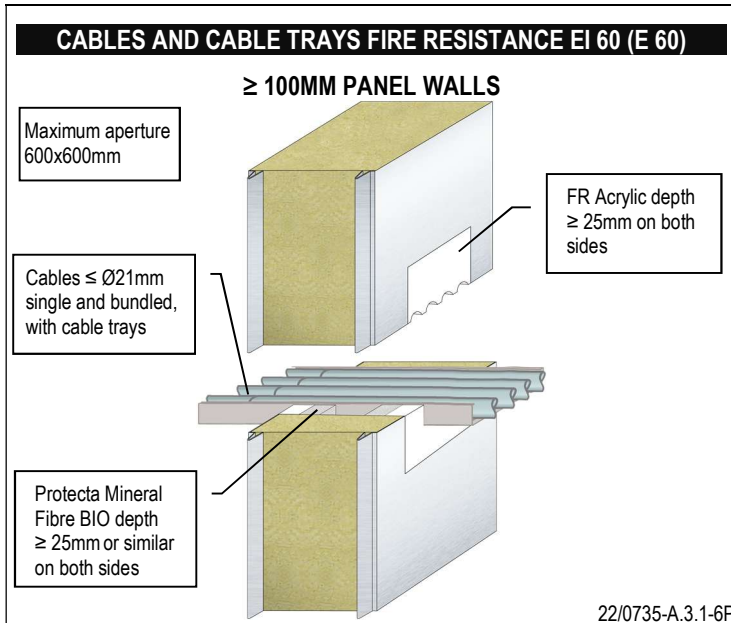

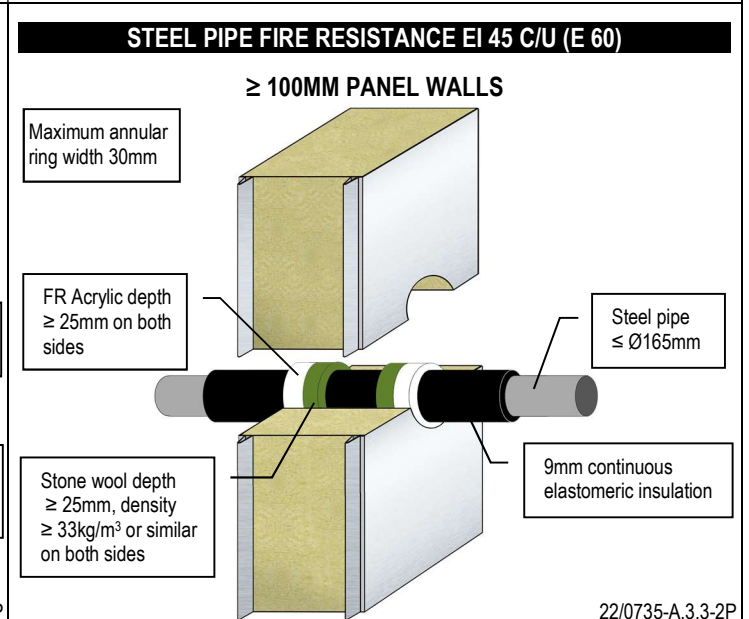
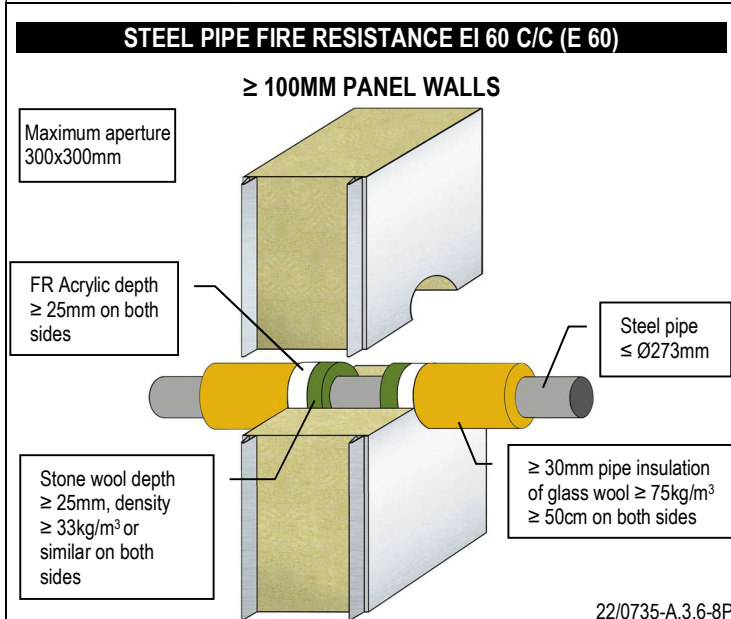
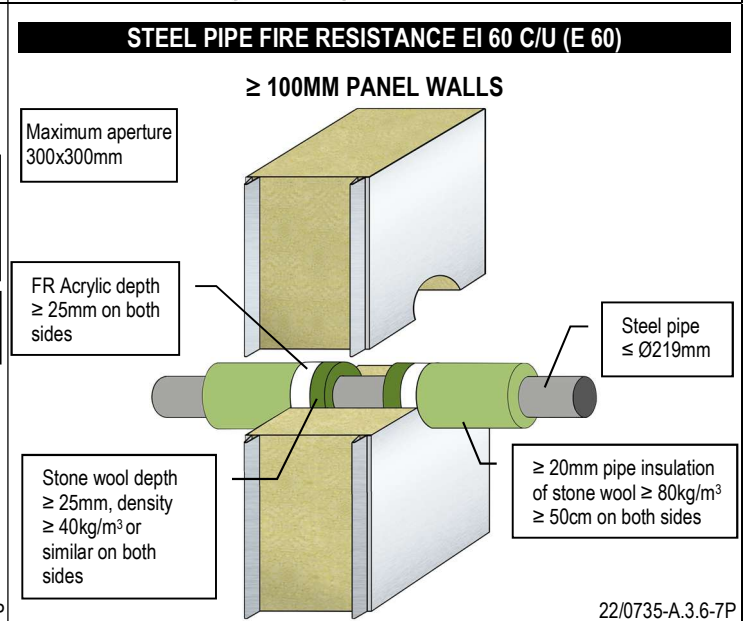
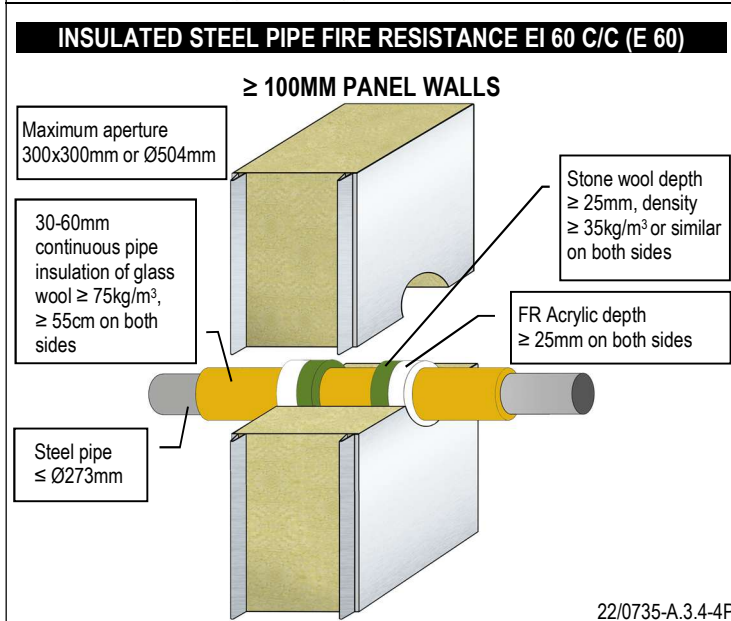
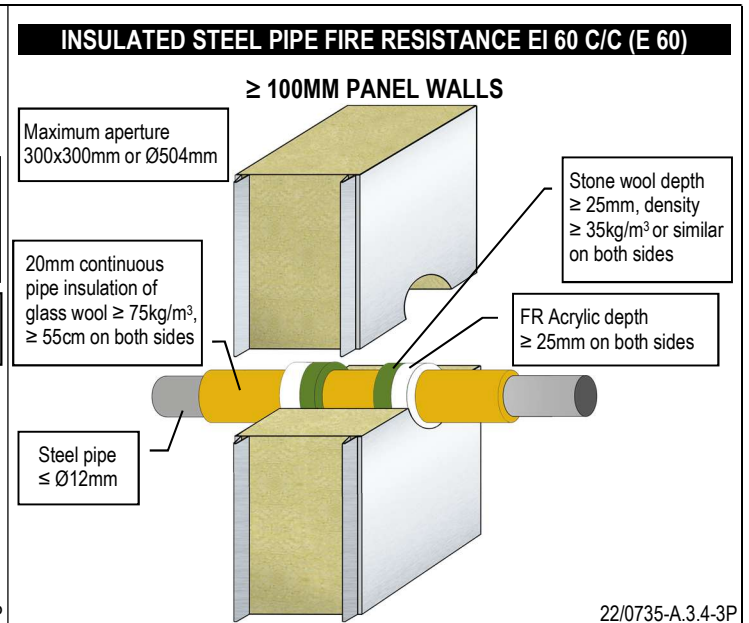
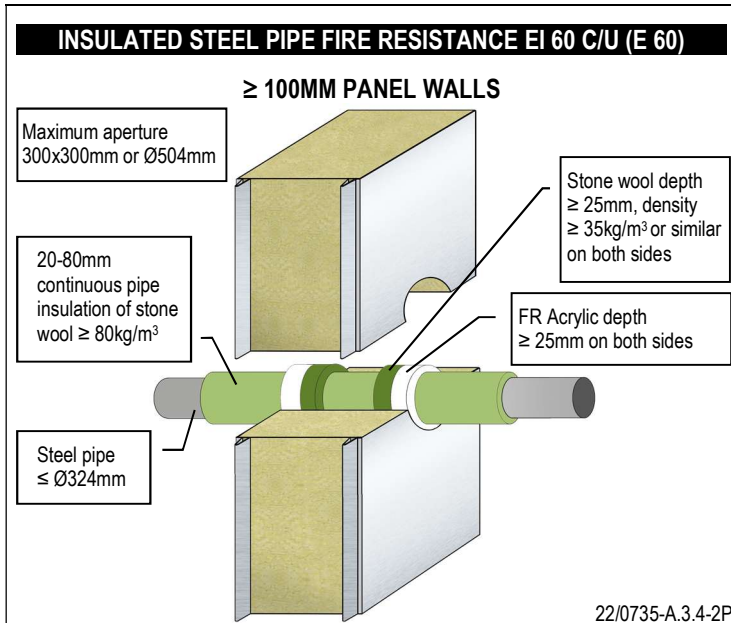

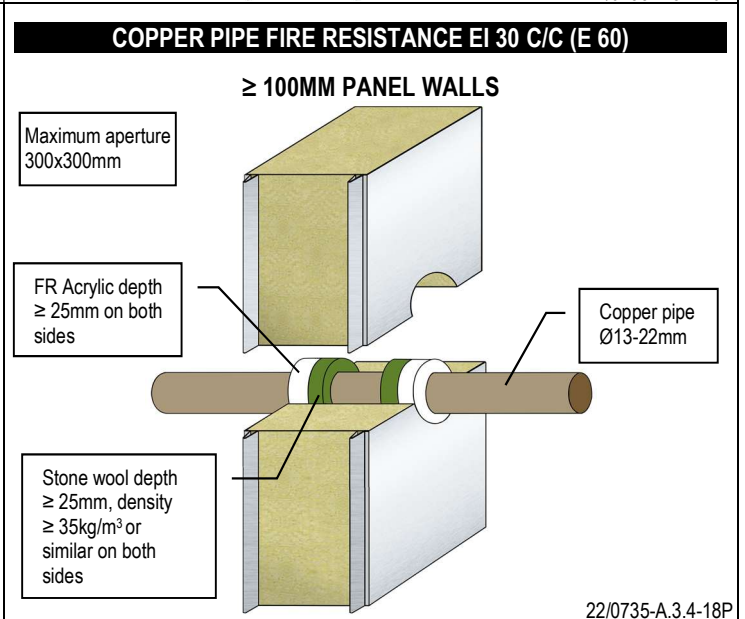
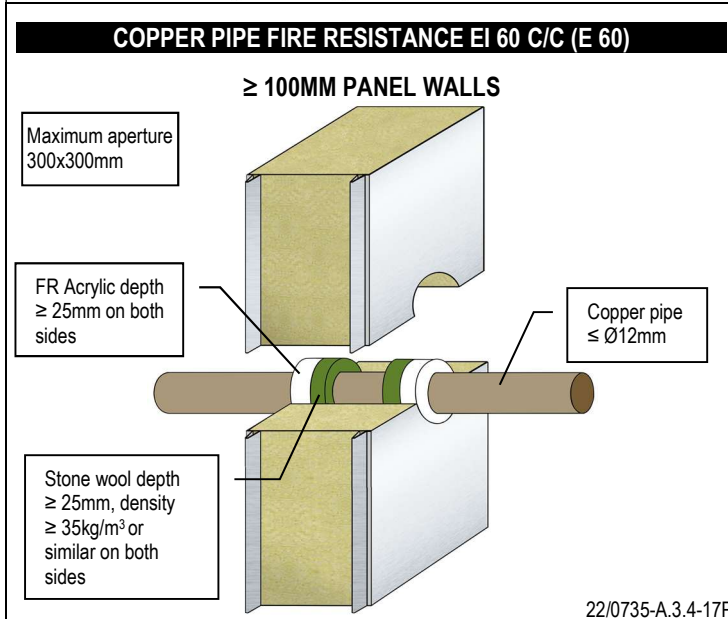
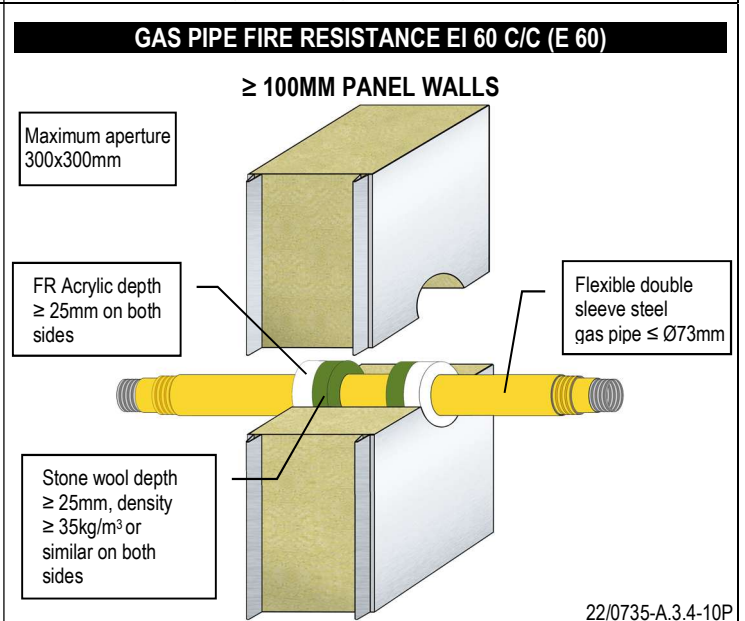
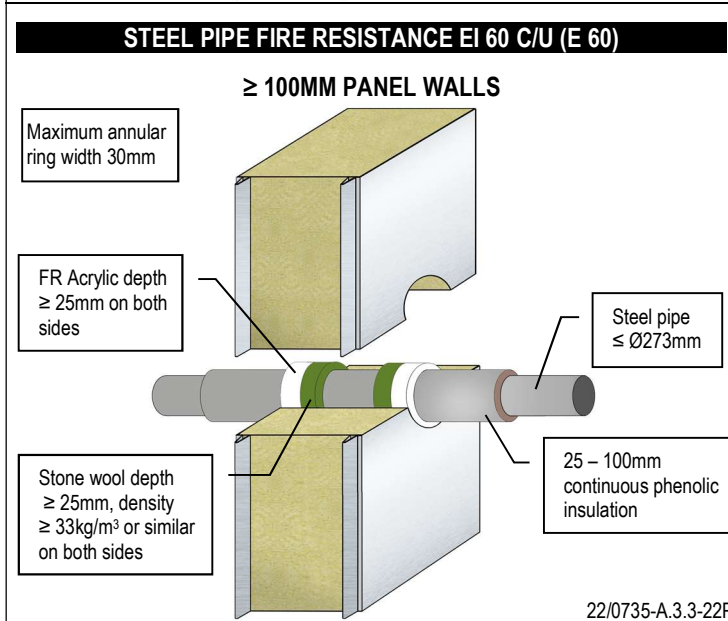
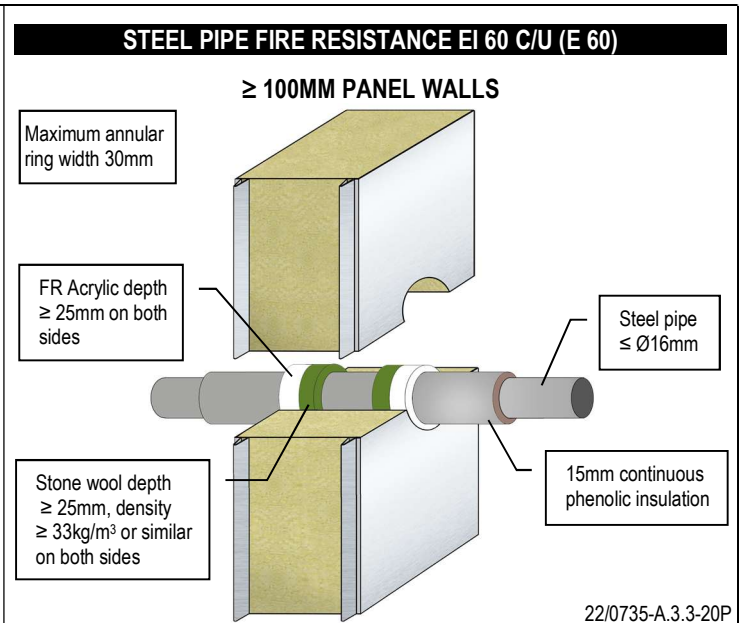
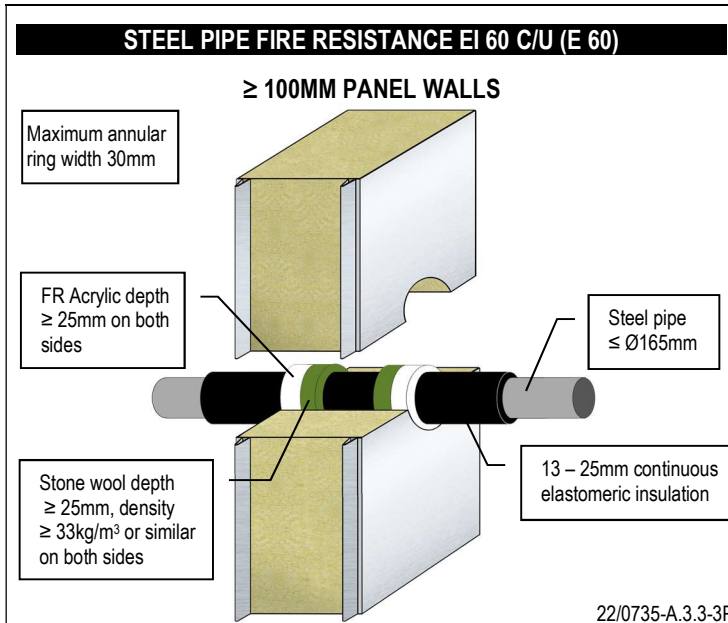

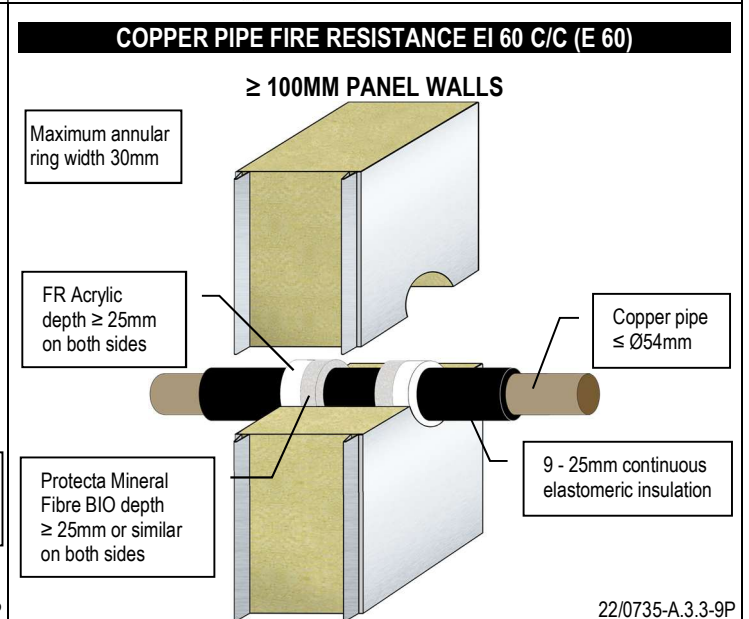
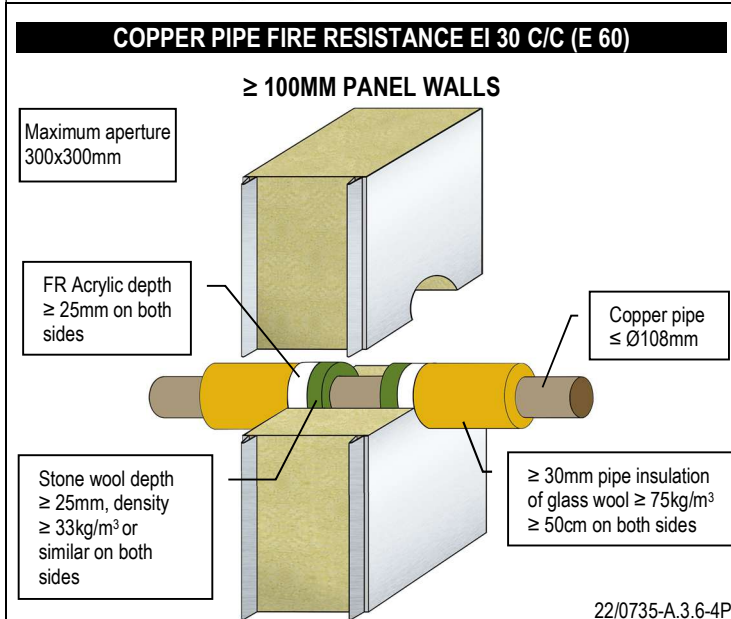
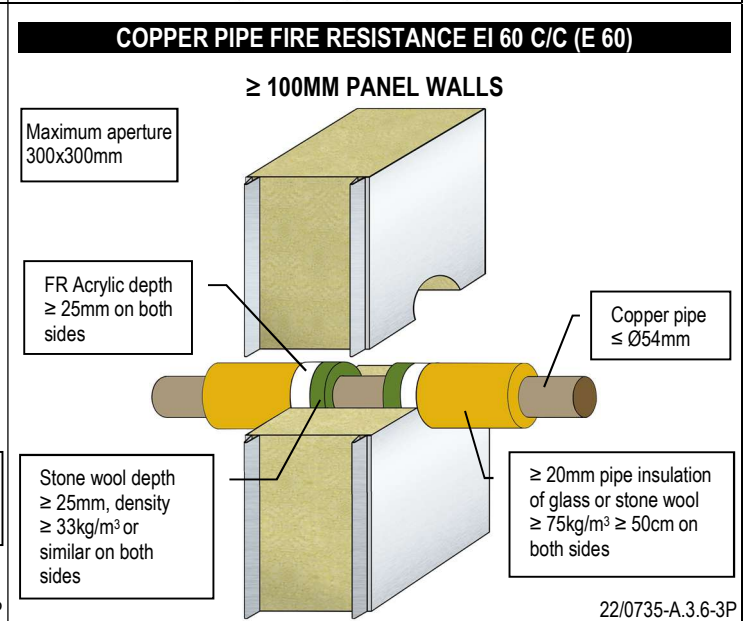
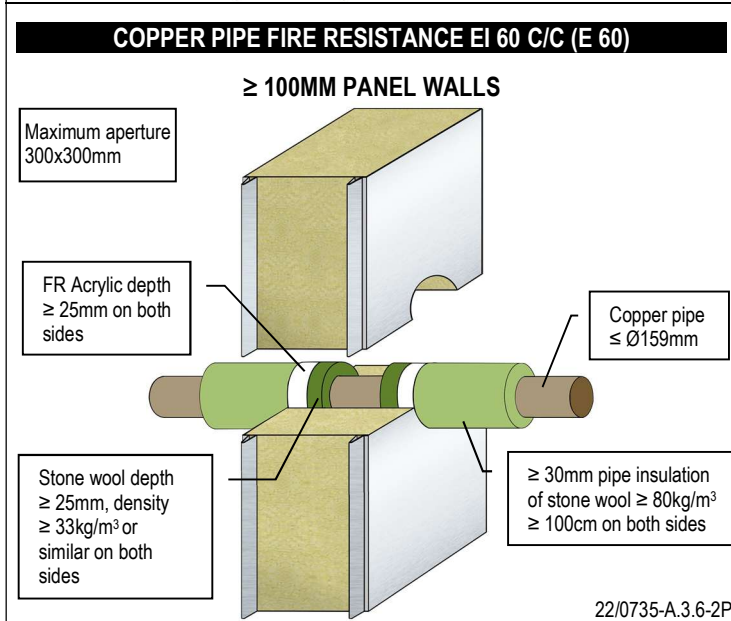
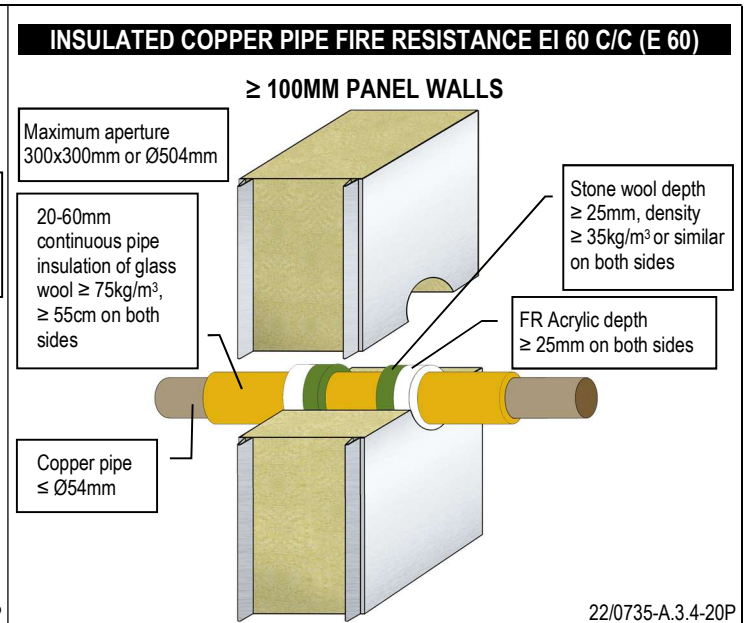
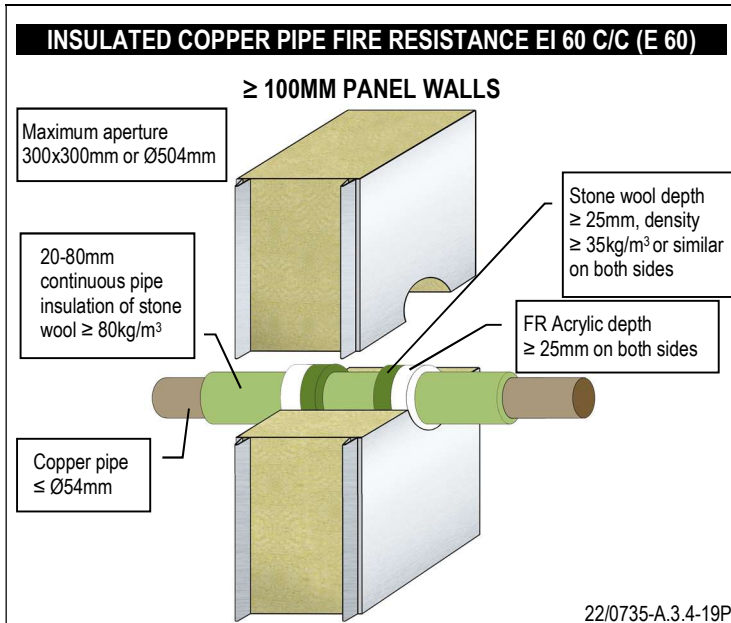

As a part of our policy of on-going product development and testing, we reserve the right to modify, alter or change product specifications without giving notice. All information contained in this document is given in good faith and is provided for guidance only. Any drawings provided are for illustrative purposes only. As Polyseam has no control over the methods or competence of installation and of prevailing site conditions, no warranties, expressed or implied, are intended to be given as to the actual performance of the product mentioned or referred to herein and no liability whatsoever will be accepted for any loss, damage or injury arising from the use of the information given.

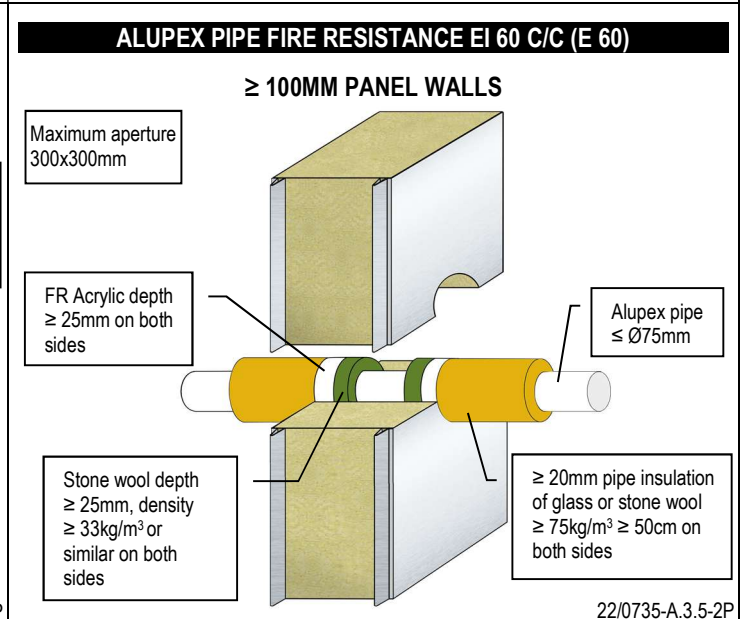
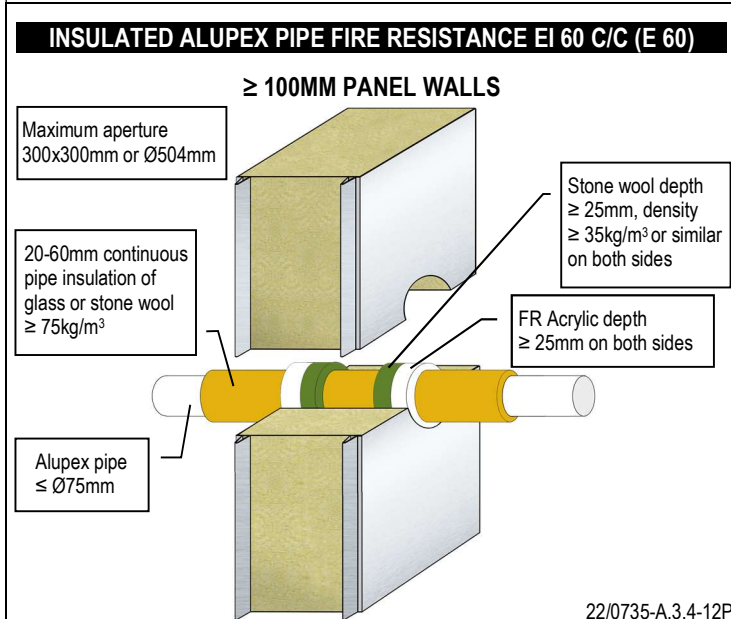
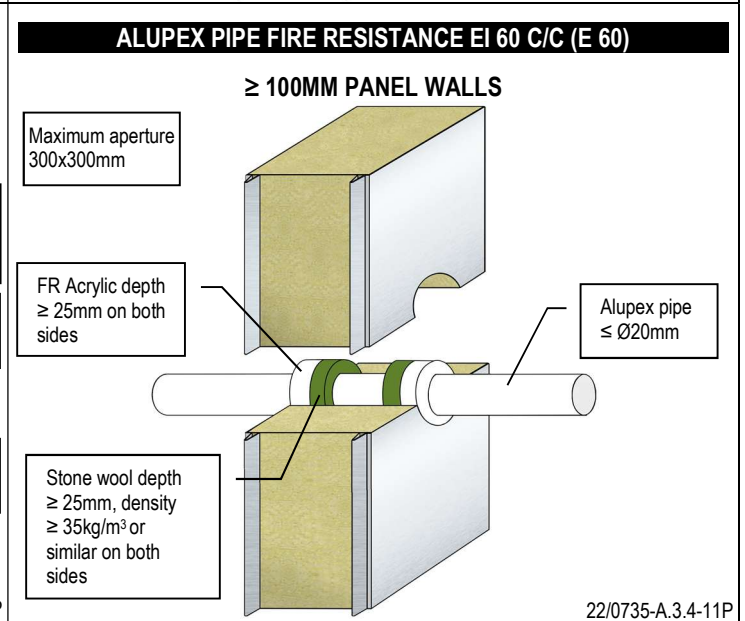
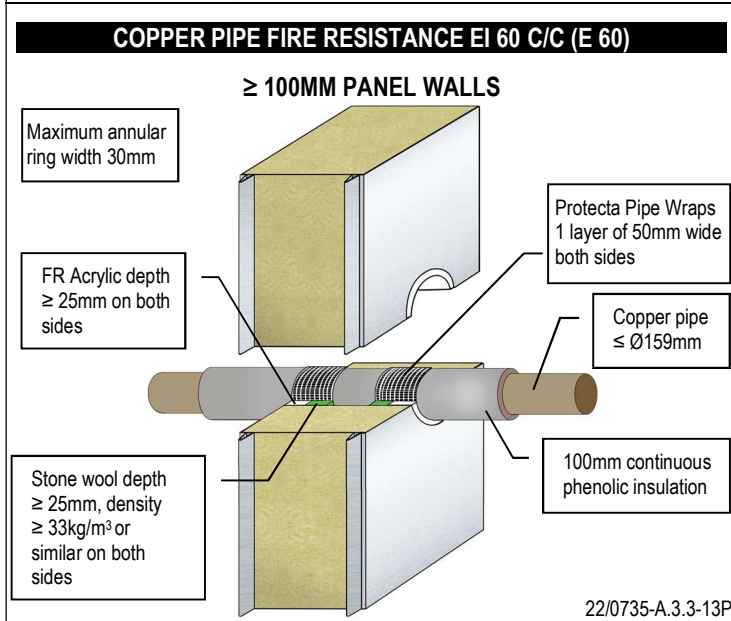
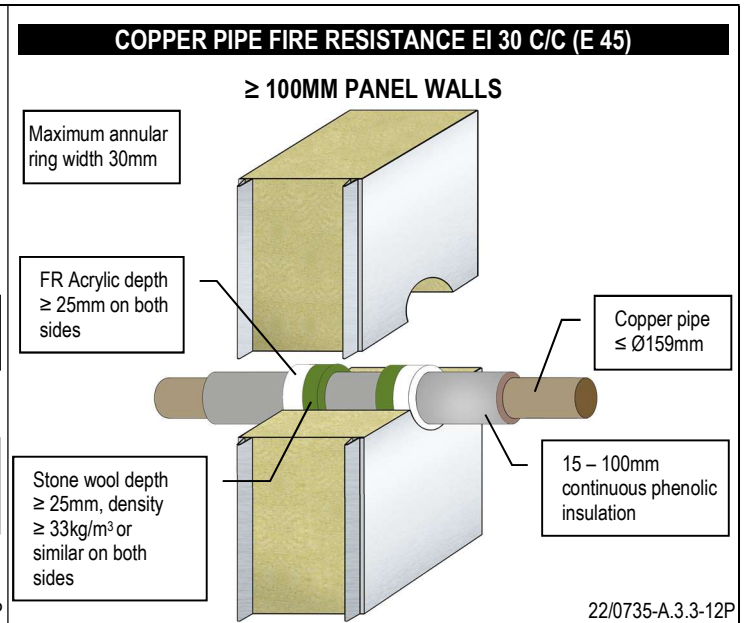
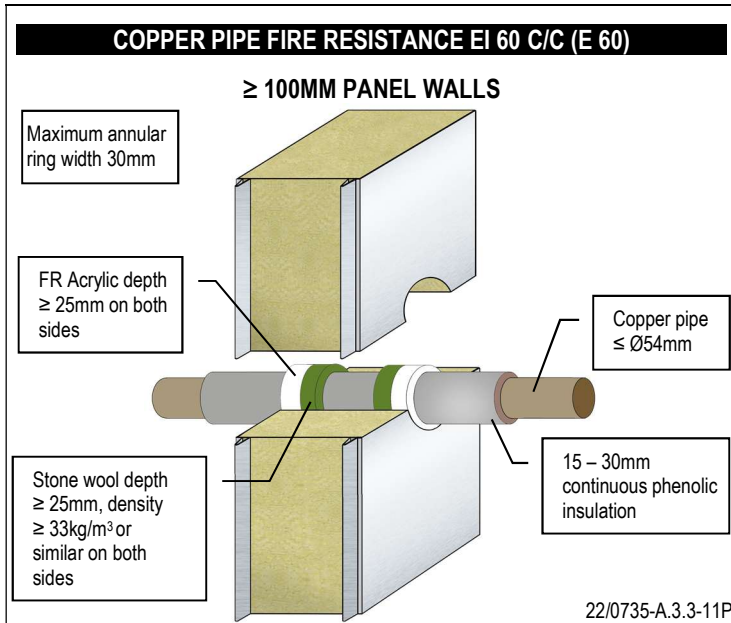

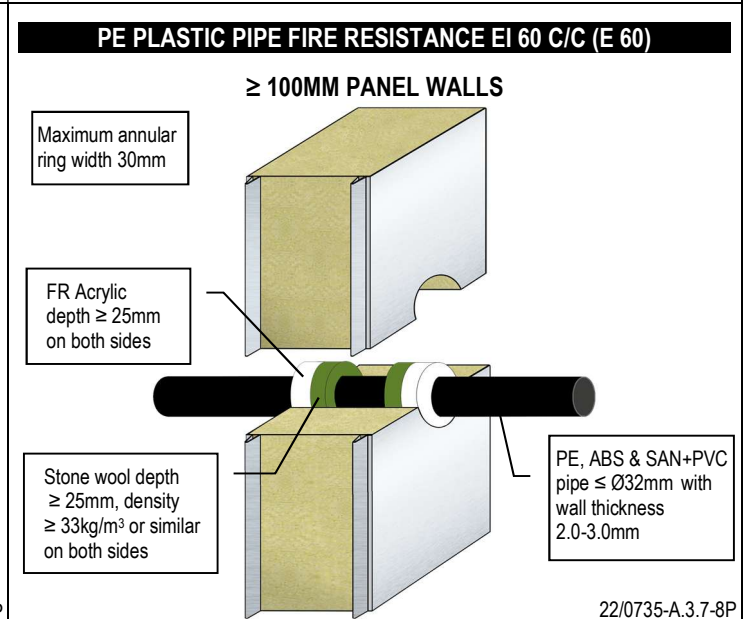
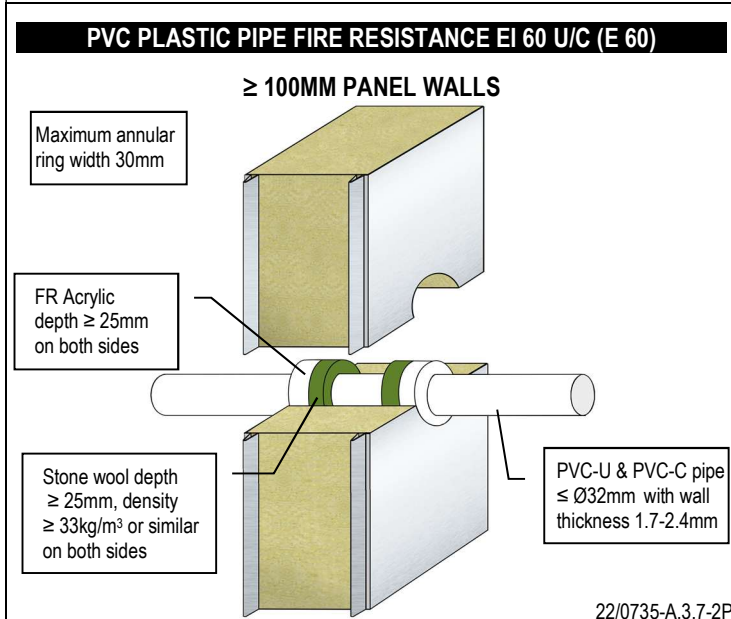
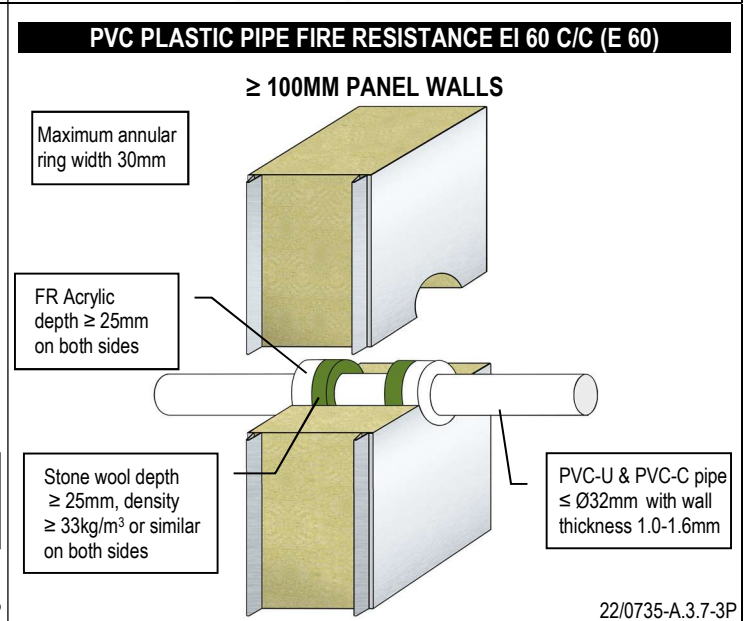
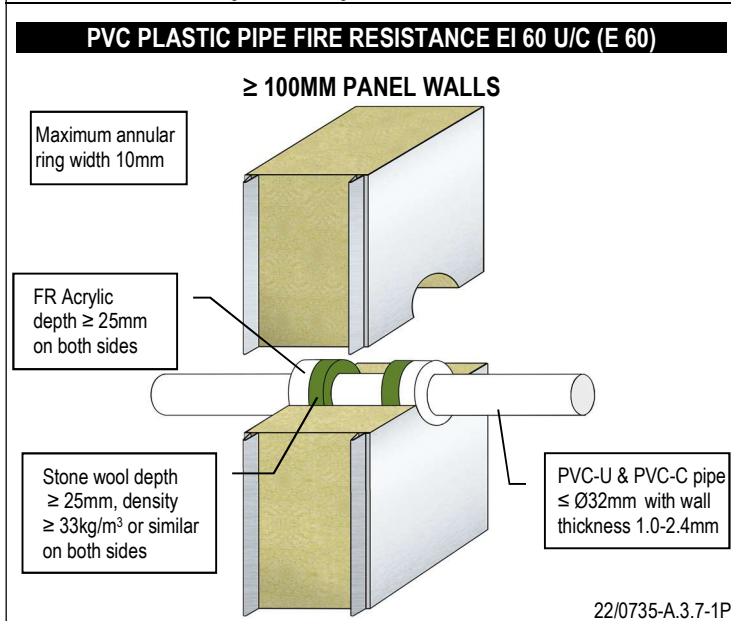
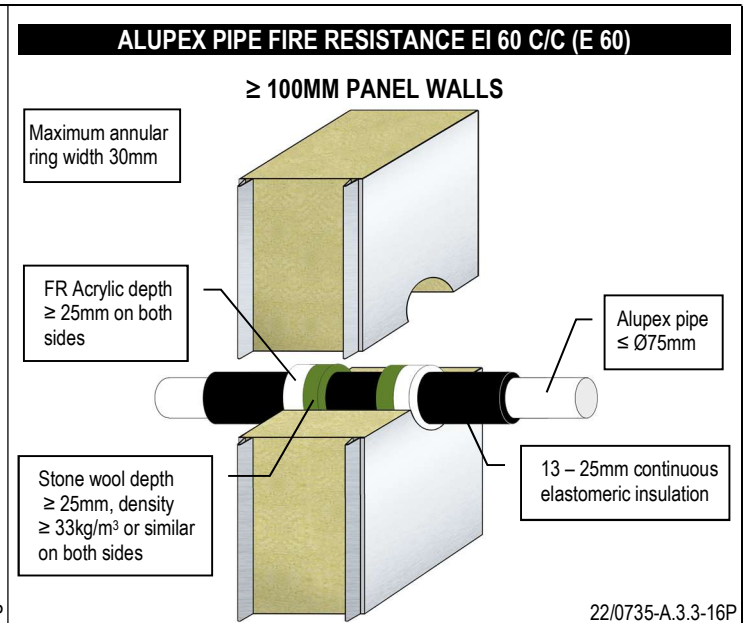
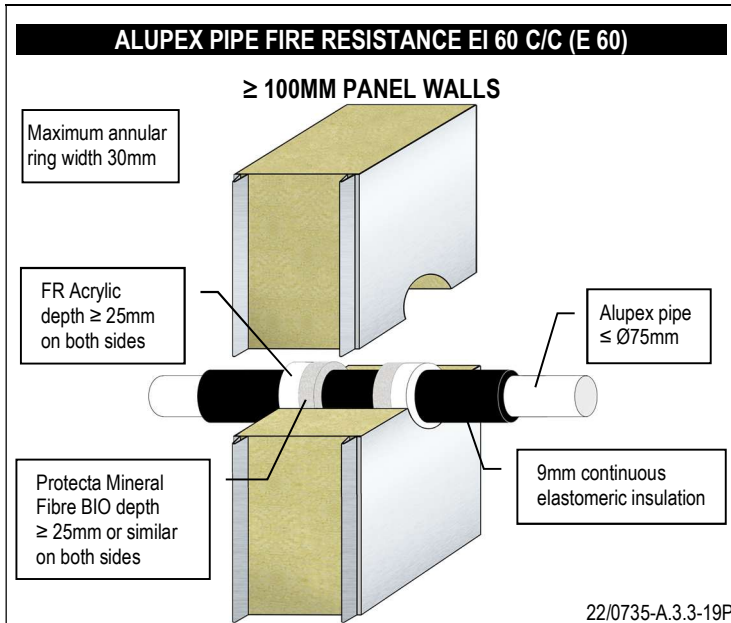

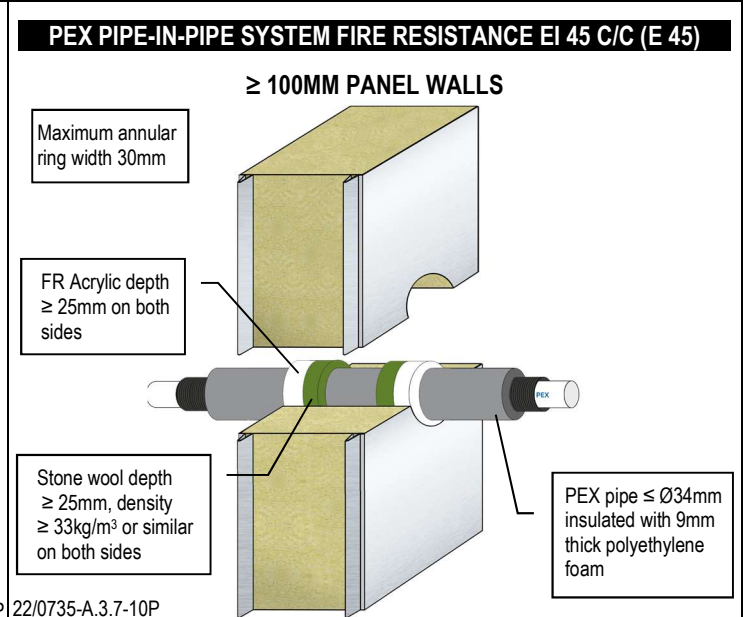
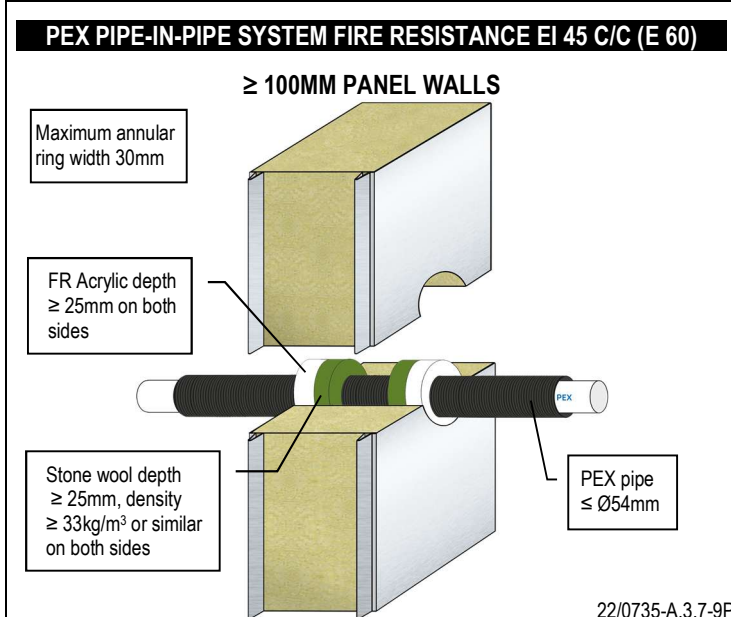
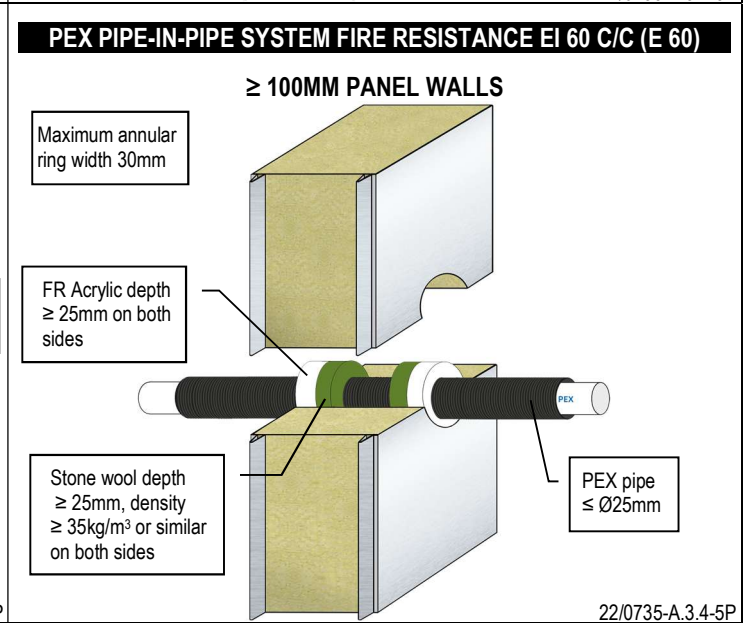
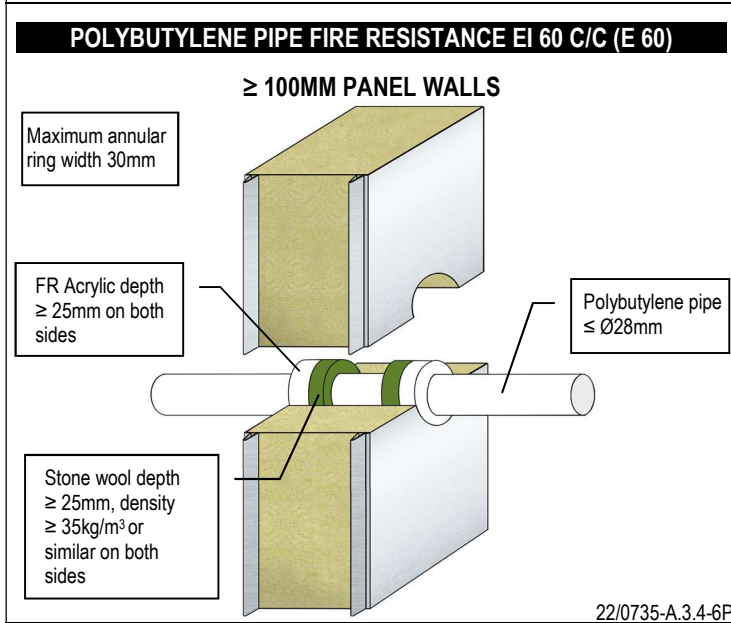
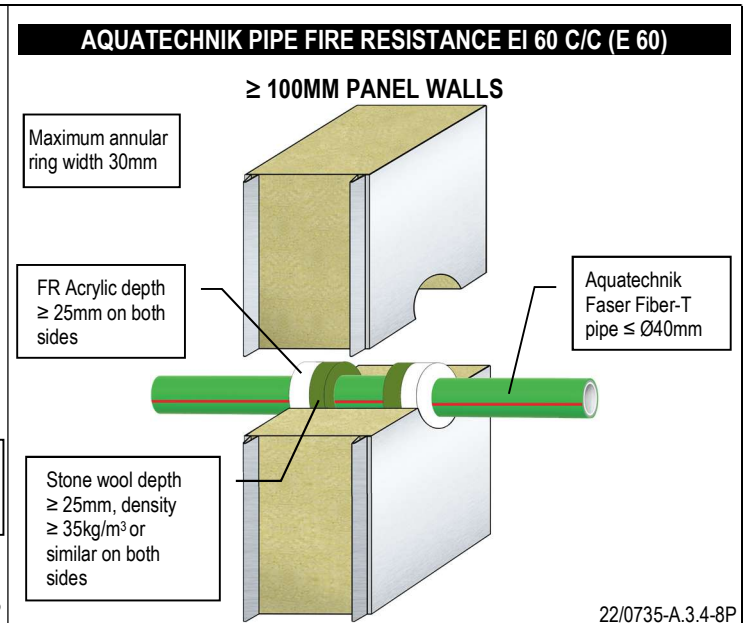
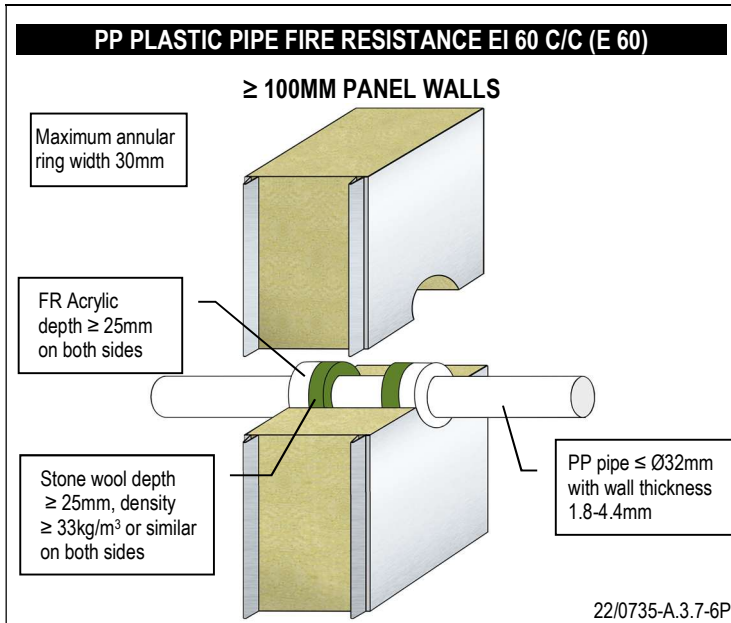

As a part of our policy of on-going product development and testing, we reserve the right to modify, alter or change product specifications without giving notice. All information contained in this document is given in good faith and is provided for guidance only. Any drawings provided are for illustrative purposes only. As Polyseam has no control over the methods or competence of installation and of prevailing site conditions, no warranties, expressed or implied, are intended to be given as to the actual performance of the product mentioned or referred to herein and no liability whatsoever will be accepted for any loss, damage or injury arising from the use of the information given.

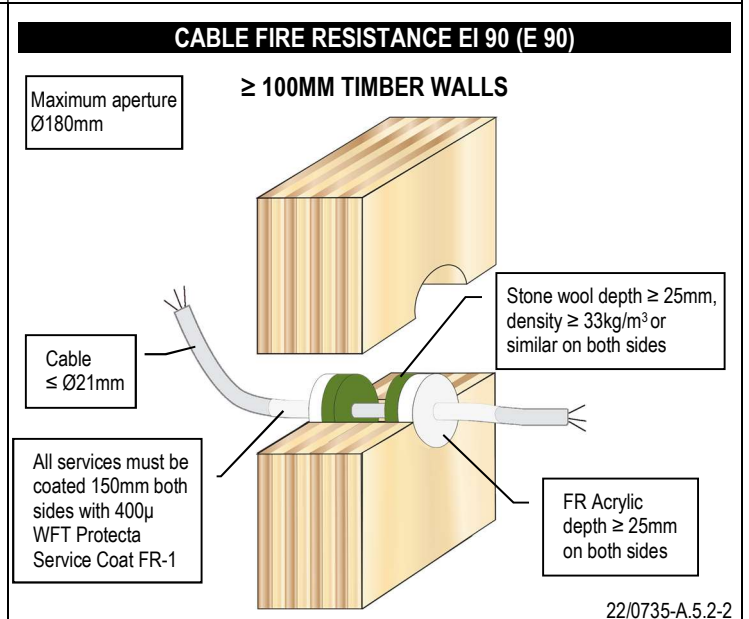
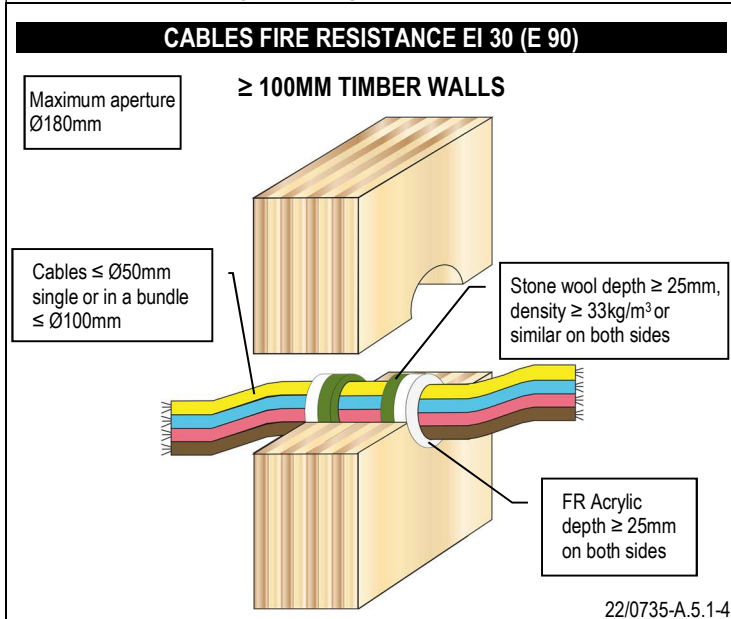
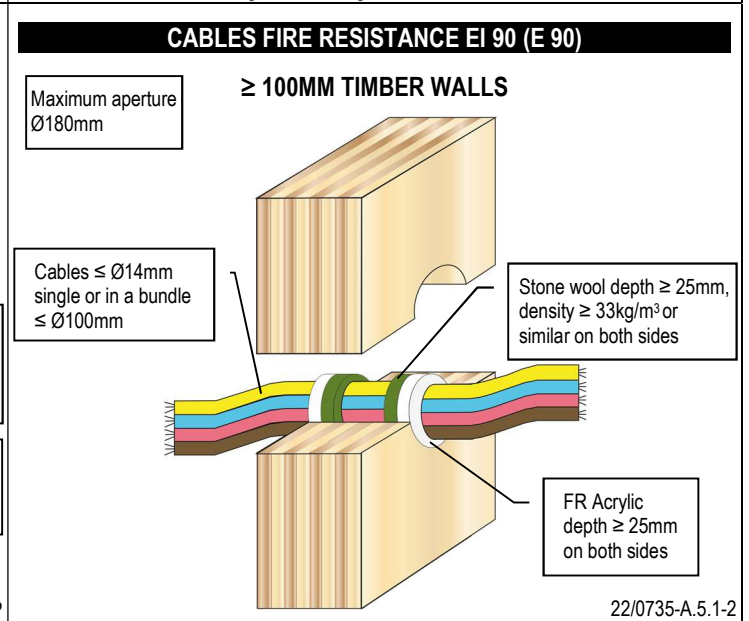
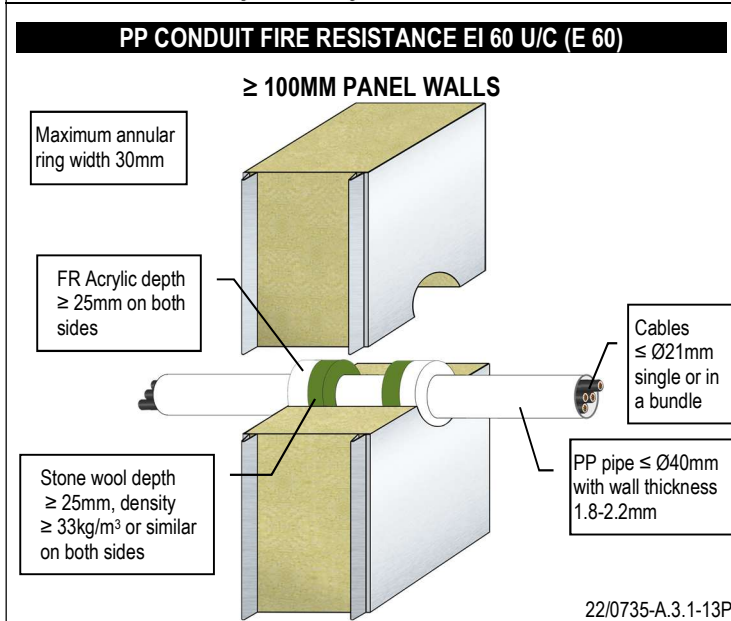
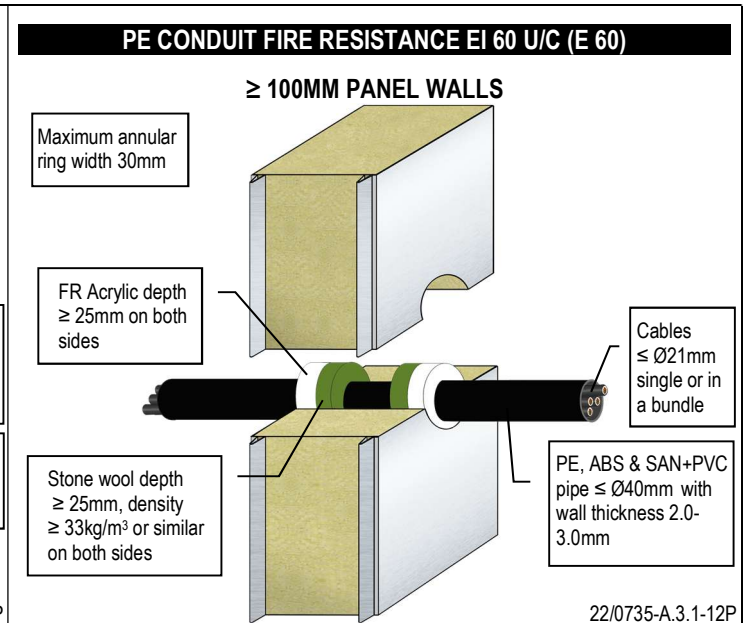
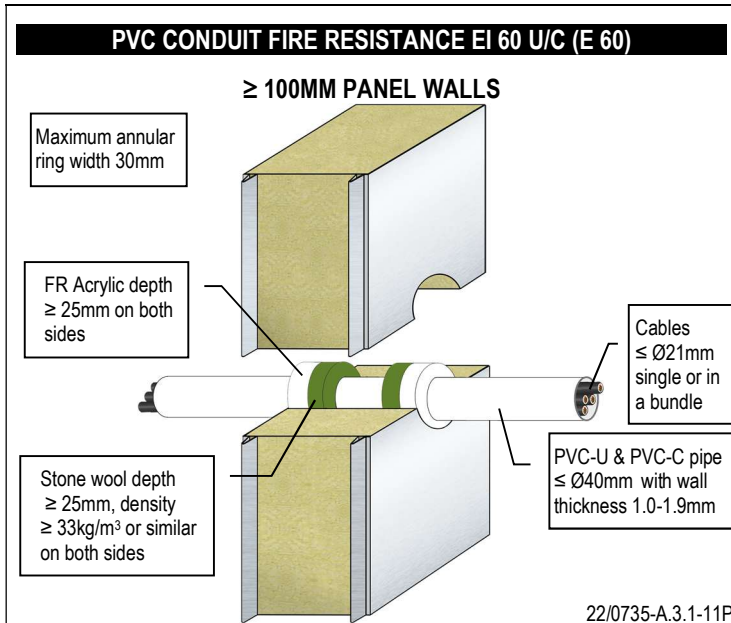

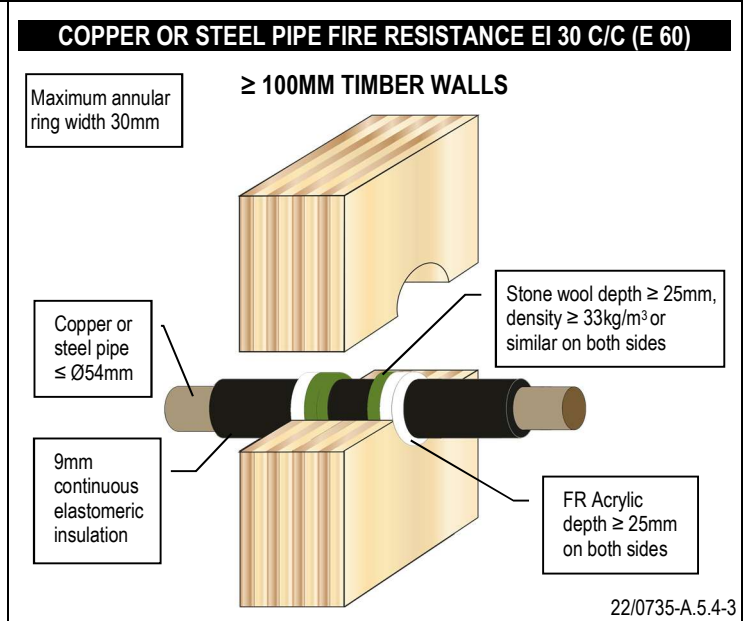
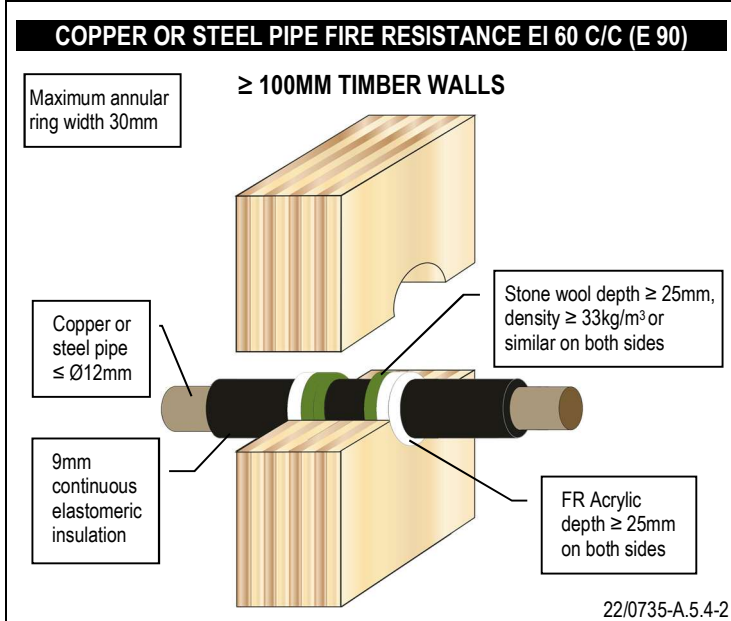
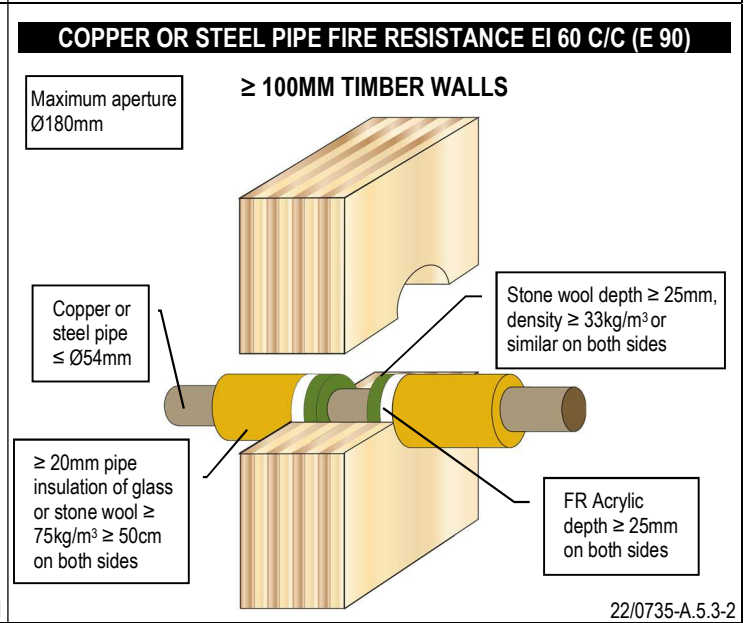
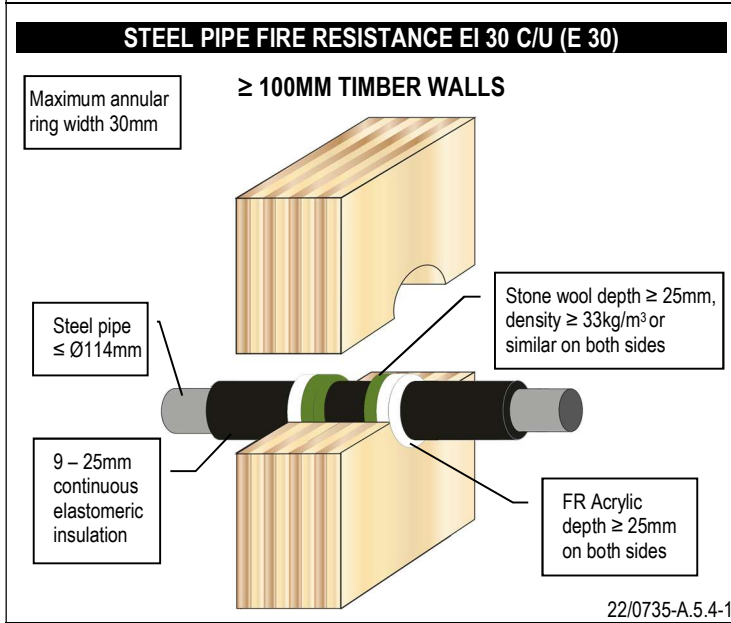
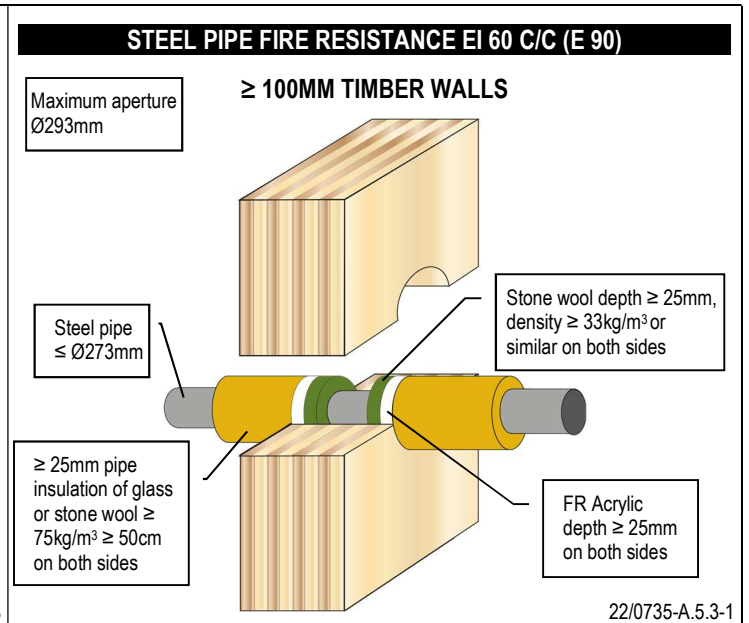
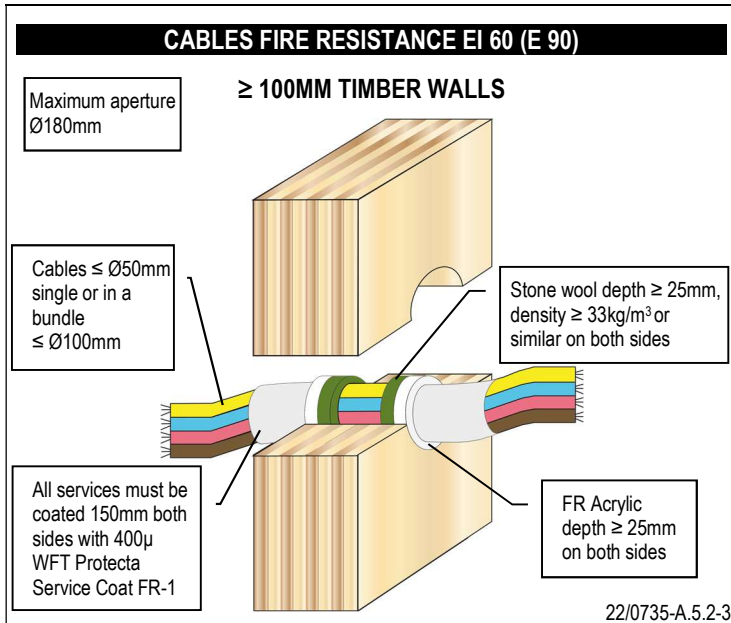

|  |  |
|--|--|
| <p><b>COPPER PIPE FIRE RESISTANCE EI 20 C/C (E 30)</b></p> <p>Maximum annular ring width 30mm</p> <p><b>≥ 100MM TIMBER WALLS</b></p> <p>Copper pipe ≤ Ø54mm</p> <p>10 – 25mm continuous elastomeric insulation</p> <p>Stone wool depth ≥ 25mm, density ≥ 33kg/m<sup>3</sup> or similar on both sides</p> <p>FR Acrylic depth ≥ 25mm on both sides</p> <p>22/0735-A.5.4-4</p> | <p><b>ALUPEX PIPE FIRE RESISTANCE EI 90 C/C (E 90)</b></p> <p>Maximum aperture Ø180mm</p> <p><b>≥ 100MM TIMBER WALLS</b></p> <p>Alupex pipe ≤ Ø75mm</p> <p>≥ 25mm pipe insulation of glass or stone wool ≥ 75kg/m<sup>3</sup> ≥ 50cm on both sides</p> <p>Stone wool depth ≥ 25mm, density ≥ 33kg/m<sup>3</sup> or similar on both sides</p> <p>FR Acrylic depth ≥ 25mm on both sides</p> <p>22/0735-A.5.3-3</p> |
| <p><b>ALUPEX PIPE FIRE RESISTANCE EI 90 C/C (E 90)</b></p> <p>Maximum annular ring width 30mm</p> <p><b>≥ 100MM TIMBER WALLS</b></p> <p>Alupex pipe ≤ Ø16mm</p> <p>9mm continuous elastomeric insulation</p> <p>Stone wool depth ≥ 25mm, density ≥ 33kg/m<sup>3</sup> or similar on both sides</p> <p>FR Acrylic depth ≥ 25mm on both sides</p> <p>22/0735-A.5.4-5</p>       | <p><b>ALUPEX PIPE FIRE RESISTANCE EI 45 C/C (E 60)</b></p> <p>Maximum annular ring width 30mm</p> <p><b>≥ 100MM TIMBER WALLS</b></p> <p>Alupex pipe ≤ Ø75mm</p> <p>9mm continuous elastomeric insulation</p> <p>Stone wool depth ≥ 25mm, density ≥ 33kg/m<sup>3</sup> or similar on both sides</p> <p>FR Acrylic depth ≥ 25mm on both sides</p> <p>22/0735-A.5.4-6</p>   |
| <p><b>ALUPEX PIPE FIRE RESISTANCE EI 45 C/C (E 45)</b></p> <p>Maximum annular ring width 30mm</p> <p><b>≥ 100MM TIMBER WALLS</b></p> <p>Alupex pipe ≤ Ø75mm</p> <p>10 – 25mm continuous elastomeric insulation</p> <p>Stone wool depth ≥ 25mm, density ≥ 33kg/m<sup>3</sup> or similar on both sides</p> <p>FR Acrylic depth ≥ 25mm on both sides</p> <p>22/0735-A.5.4-7</p> | <p><b>PVC PIPE FIRE RESISTANCE EI 90 U/C (E 90)</b></p> <p>Maximum annular ring width 30mm</p> <p><b>≥ 100MM TIMBER WALLS</b></p> <p>PVC pipe ≤ Ø32mm with wall thickness 1.0-2.4mm</p> <p>Stone wool depth ≥ 25mm, density ≥ 33kg/m<sup>3</sup> or similar on both sides</p> <p>FR Acrylic depth ≥ 25mm on both sides</p> <p>22/0735-A.5.5-1</p>  |

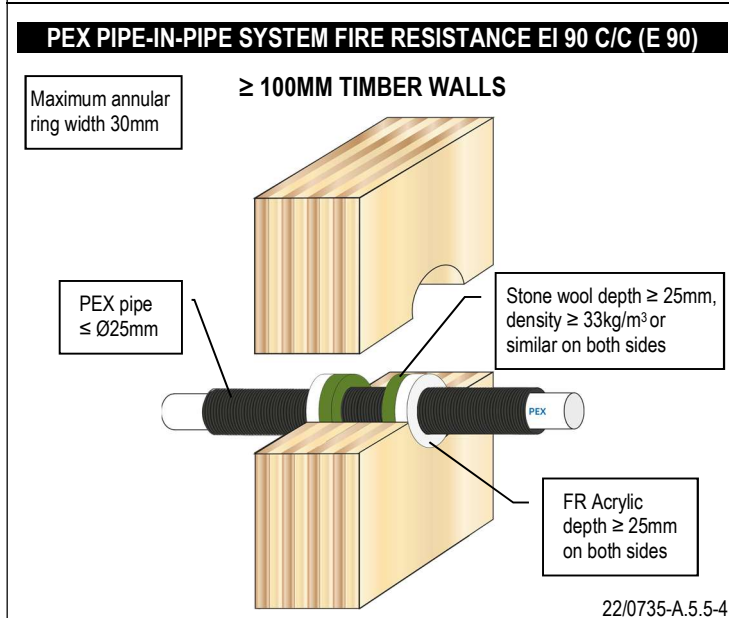
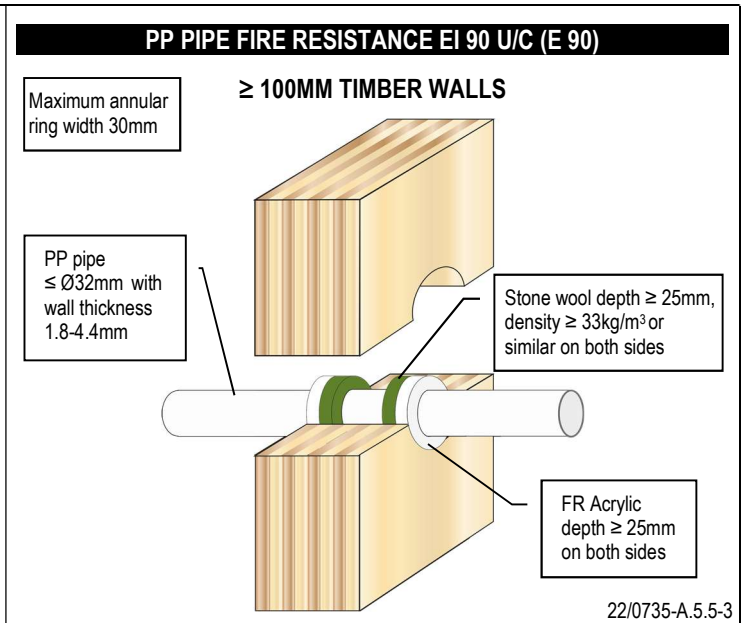
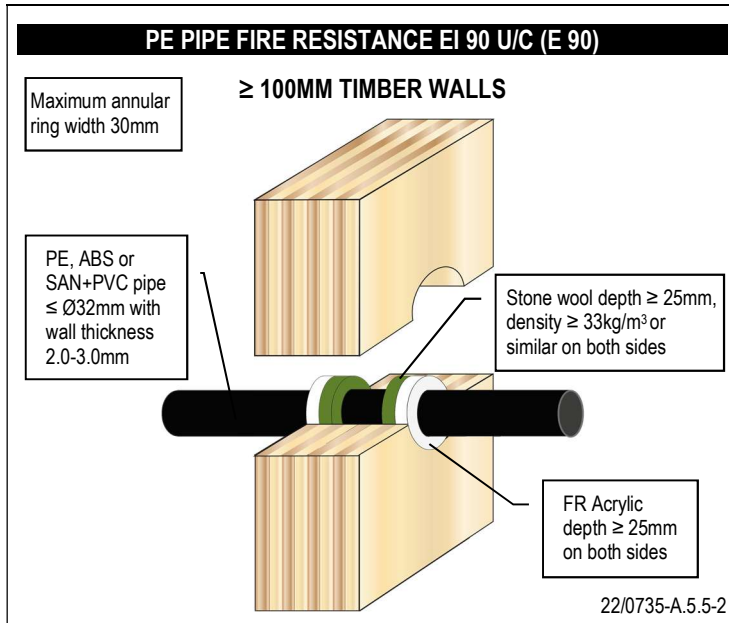

# INDEX

## Rigid floors

| Services                   | Service insulation                           | Page no. |
|----------------------------|--|----------|
| Linear seals               | -  | 2 – 3    |
| Cables                     | -  | 4        |
| Unistrut channel           | -  | 5        |
| Steel pipes                | -  | 5        |
| “                          | Coat-back                                    | 5 – 6    |
| “                          | Glass- & stone-wool, continuous              | 6        |
| “                          | Glass- & stone-wool, interrupted             | 6 – 8    |
| “                          | Elastomeric, phenolic or PU-foam, continuous | 8        |
| Gas pipes                  | -  | 8        |
| Copper pipes               | -  | 8 – 9    |
| “                          | Glass- & stone-wool, continuous              | 9 – 10   |
| “                          | Glass- & stone-wool, interrupted             | 10 – 11  |
| “                          | Elastomeric, phenolic or PU-foam, continuous | 11       |
| Alupex pipes               | -  | 11 – 12  |
| “                          | Glass- & stone-wool, continuous              | 12       |
| “                          | Glass- & stone-wool, interrupted             | 12       |
| “                          | Elastomeric, phenolic or PU-foam, continuous | 13       |
| Plastic PVC, PE & PP pipes | -  | 13 – 14  |
| Plastic Aquatechnik pipes  | -  | 14       |
| Plastic Polybutylene pipes | -  | 14       |
| Plastic PEX pipe-in-pipes  | -  | 14       |
| “                          | Polyethylene foam, continuous                | 15       |
| Plastic conduits           | -  | 15       |

## Flexible floors

| Services                   | Service insulation               | Page no. |
|----------------------------|----------------------------------|----------|
| Cables                     | -                                | 15       |
| Steel pipes                | -                                | 16       |
| “                          | Glass- & stone-wool, continuous  | 16       |
| “                          | Glass- & stone-wool, interrupted | 16       |
| Copper pipes               | -                                | 17       |
| “                          | Glass- & stone-wool, continuous  | 17       |
| “                          | Glass- & stone-wool, interrupted | 17       |
| Alupex pipes               | -                                | 18       |
| “                          | Glass- & stone-wool, continuous  | 18       |
| “                          | Glass- & stone-wool, interrupted | 18       |
| Plastic PVC, PE & PP pipes | -                                | 18 – 20  |
| Plastic PEX pipe-in-pipes  | -                                | 21       |
| Plastic conduits           | -                                | 22       |

## Timber floors

| Services                   | Service insulation               | Page no. |
|----------------------------|----------------------------------|----------|
| Cables                     | -                                | 22       |
| Steel pipes                | Glass- & stone-wool, interrupted | 23       |
| Copper pipes               | Glass- & stone-wool, interrupted | 23       |
| Alupex pipes               | Glass- & stone-wool, interrupted | 23       |
| Plastic PVC, PE & PP pipes | -                                | 23 – 24  |
| Plastic PEX pipe-in-pipes  | -                                | 24       |

## Flexible and rigid walls

| Services                         | Service insulation               | Page no. |
|----------------------------------|----------------------------------|----------|
| Linear seals                     | -                                | 31 – 33  |
| Cables                           | -                                | 33 – 34  |
| Cables & conduits on cable trays | -                                | 34       |
| Unistrut channel                 | -                                | 34       |
| Steel pipes                      | -                                | 34 – 35  |
| “                                | Coat-back                        | 35       |
| “                                | Glass- & stone-wool, continuous  | 35 – 36  |
| “                                | Glass- & stone-wool, interrupted | 36       |
| “                                | Elastomeric, continuous          | 37       |
| “                                | Phenolic, continuous             | 37 – 38  |
| Gas pipes                        | -                                | 38       |
| Copper pipes                     | -                                | 38       |
| “                                | Glass- & stone-wool, continuous  | 39       |
| “                                | Glass- & stone-wool, interrupted | 39       |
| “                                | Elastomeric, continuous          | 40       |
| “                                | Phenolic, continuous             | 40 – 41  |
| Alupex pipes                     | -                                | 41       |
| “                                | Glass- & stone-wool, continuous  | 41       |
| “                                | Glass- & stone-wool, interrupted | 42       |
| “                                | Elastomeric, continuous          | 42 – 43  |
| Plastic PVC, PE & PP pipes       | -                                | 43 – 44  |
| Plastic Aquatechnik pipes        | -                                | 44       |
| Plastic Polybutylene pipes       | -                                | 45       |
| Plastic PEX pipe-in-pipes        | -                                | 45       |
| “                                | Polyethylene foam, continuous    | 45       |
| Plastic conduits                 | -                                | 45 – 46  |

## Rigid walls, additional items

| Services                   | Service insulation      | Page no. |
|----------------------------|-------------------------|----------|
| Linear seals               | -                       | 24 – 25  |
| Cables                     | -                       | 25 – 26  |
| Steel pipes                | -                       | 26       |
| “                          | Stone-wool, continuous  | 26 – 27  |
| “                          | Stone-wool, interrupted | 27       |
| “                          | Elastomeric, continuous | 28       |
| Copper pipes               | -                       | 28       |
| “                          | Stone-wool, interrupted | 28 - 29  |
| Alupex pipes               | BIO-wool, interrupted   | 29       |
| Plastic PVC, PE & PP pipes | -                       | 29 – 30  |
| Plastic conduits           | -                       | 30 - 31  |

## Panel walls

| Services                         | Service insulation               | Page no. |
|----------------------------------|----------------------------------|----------|
| Cables                           | -                                | 46       |
| Cables & conduits on cable trays | -                                | 47       |
| Unistrut channel                 | -                                | 47       |
| Steel pipes                      | -                                | 47       |
| “                                | Coat-back                        | 47       |
| “                                | Glass- & stone-wool, continuous  | 48       |
| “                                | Glass- & stone-wool, interrupted | 48       |
| “                                | Elastomeric, continuous          | 48 – 49  |
| “                                | Phenolic, continuous             | 49       |
| Gas pipes                        | -                                | 49       |
| Copper pipes                     | -                                | 49       |
| “                                | Glass- & stone-wool, continuous  | 50       |
| “                                | Glass- & stone-wool, interrupted | 50       |
| “                                | Elastomeric, continuous          | 50       |
| “                                | Phenolic, continuous             | 51       |
| Alupex pipes                     | -                                | 51       |
| “                                | Glass- & stone-wool, continuous  | 51       |
| “                                | Glass- & stone-wool, interrupted | 51       |
| “                                | Elastomeric, continuous          | 52       |
| Plastic PVC, PE & PP pipes       | -                                | 52 – 53  |
| Plastic Aquatechnik pipes        | -                                | 53       |
| Plastic Polybutylene pipes       | -                                | 53       |
| Plastic PEX pipe-in-pipes        | -                                | 53       |
| “                                | Polyethylene foam, continuous    | 53       |
| Plastic conduits                 | -                                | 54       |

## Timber walls

| Services                   | Service insulation               | Page no. |
|----------------------------|----------------------------------|----------|
| Cables                     | -                                | 54 – 55  |
| Steel pipes                | Glass- & stone-wool, interrupted | 55       |
| “                          | Elastomeric, continuous          | 55       |
| Copper pipes               | Glass- & stone-wool, interrupted | 55       |
| “                          | Elastomeric, continuous          | 55 – 56  |
| Alupex pipes               | Glass- & stone-wool, interrupted | 56       |
| “                          | Elastomeric, continuous          | 56       |
| Plastic PVC, PE & PP pipes | -                                | 56 – 57  |
| Plastic PEX pipe-in-pipes  | -                                | 57       |